



## HOW TO USE THIS MANUAL

This shop manual covers emission controlled CX500's manufactured after December 31, 1977. Some procedures may not apply to earlier units.

This shop manual uses the 1978 CX500 as the basis for all service procedures and data. The manual is kept up-to-date with subsequent addendums beginning with section 21.

Follow the applicable Maintenance Schedule recommendations to ensure that the vehicle is in peak operating condition and the emission levels are within U.S. Environmental Protection Agency standards. Performing the first scheduled maintenance is very important. It compensates for the initial wear that occurs during break-in.

Sections 1 through 3 apply to the whole motorcycle, while sections 4 through 18 describe parts of the motorcycle, grouped according to location.

Find the section you want on this page, then turn to the table of contents on page 1 of that section.

Most sections start with an assembly or system illustration and all the required specifications, torque values, working practices, tools and materials required for the section. The subsequent pages give detailed procedures for the section.

If you are not familiar with this motorcycle, read through the TECHNICAL FEATURES in section 19.

If you don't know the source of the trouble, go to section 20 TROUBLESHOOTING.

ALL INFORMATION, ILLUSTRATIONS, DIRECTIONS AND SPECIFICATIONS INCLUDED IN THIS PUBLICATION ARE BASED ON THE LATEST PRODUCT INFORMATION AVAILABLE AT THE TIME OF APPROVAL FOR PRINTING. HONDA MOTOR CO., LTD. RESERVES THE RIGHT TO MAKE CHANGES AT ANY TIME WITHOUT NOTICE AND WITHOUT INCURRING ANY OBLIGATION WHATSOEVER. NO PART OF THIS PUBLICATION MAY BE REPRODUCED WITHOUT WRITTEN PERMISSION.

HONDA MOTOR CO., LTD.  
Service Publications Office

## TABLE OF CONTENTS

	GENERAL INFORMATION	1
	LUBRICATION	2
	INSPECTION AND ADJUSTMENT	3
ENGINE	FUEL SYSTEM	4
	ENGINE REMOVAL/INSTALLATION	5
	CYLINDER HEAD/VALVE	6
	CLUTCH/OIL PUMP	7
	A.C. GENERATOR/FLYWHEEL/REAR COVER	8
	COOLING SYSTEM	9
	CAMSHAFT/CAM CHAIN	10
	TRANSMISSION	11
	CRANKSHAFT/PISTON	12
	CHASSIS	FRONT WHEEL/SUSPENSION
REAR WHEEL/BRAKE/FINAL DRIVE/SUSPENSION		14
HYDRAULIC DISC BRAKE		15
ELECTRICAL	BATTERY/CHARGING SYSTEM	16
	IGNITION SYSTEM	17
	STARTER SYSTEM	18
	TECHNICAL FEATURES	19
	TROUBLESHOOTING	20
ADDENDUMS	'79 ADDENDUM	21
	'79 DELUXE/CUSTOM ADDENDUM	22
	'80 DELUXE/CUSTOM ADDENDUM	23
	'81 DELUXE/CUSTOM ADDENDUM	24
	'82 CUSTOM ADDENDUM	25





## MODEL IDENTIFICATION

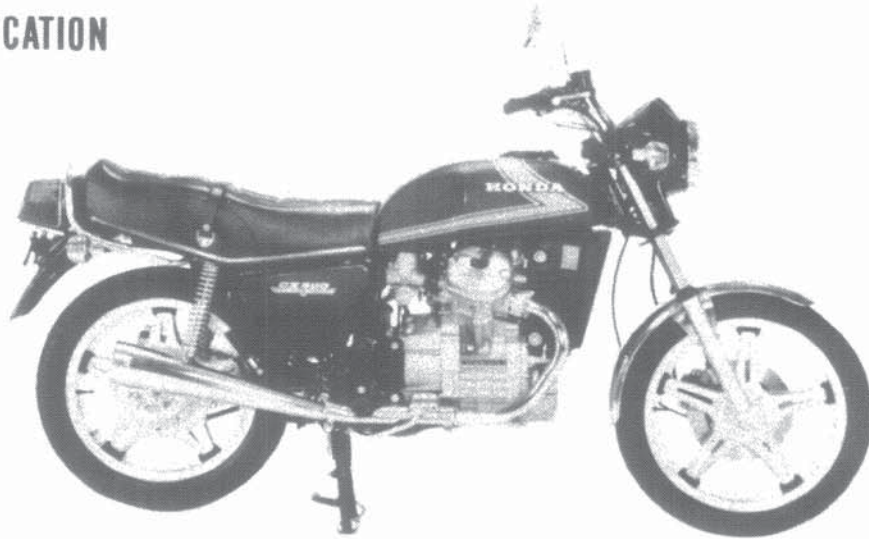

BEGINNING WITH F/N 2000001

The frame serial number is stamped on the right side of the steering head.

The legal vehicle identification number is on the left side of the steering head.

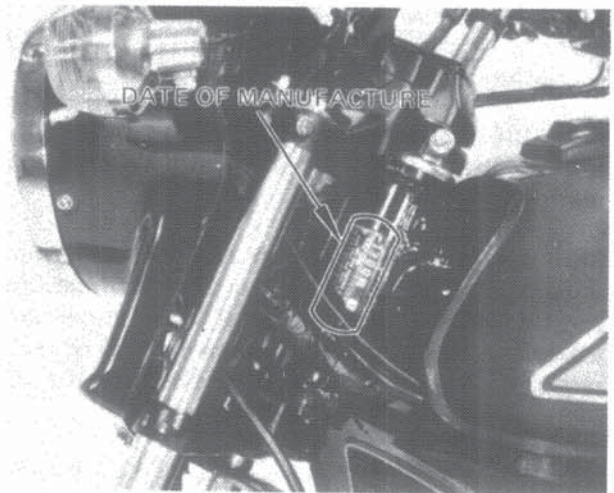
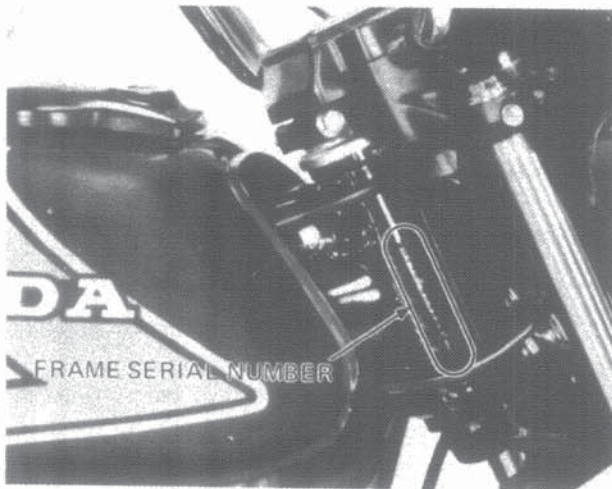

The engine serial number is stamped on the lower left side of the engine case.

The carburetor identification number is on the left side of the carburetor body.

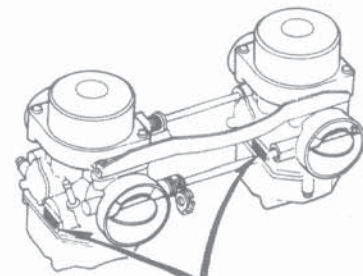
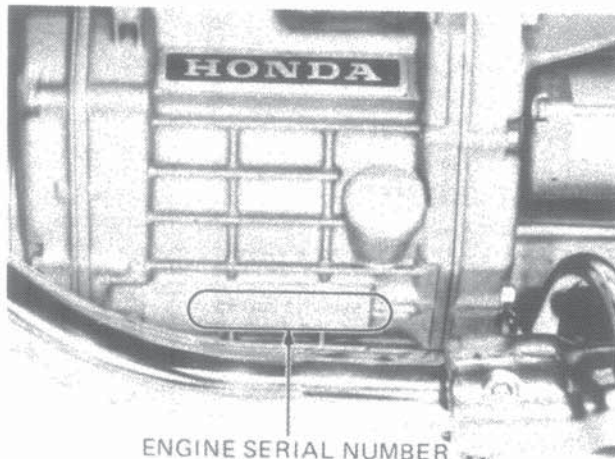

IDENTIFICATION NUMBER





# 1. GENERAL INFORMATION

GENERAL SAFETY	1-1	WIRING DIAGRAM	1-6
SERVICE RULES	1-1	CABLE & HARNESS ROUTING	1-7
SPECIFICATIONS	1-2	EMISSION CONTROL SYSTEM	1-8
TORQUE VALUES	1-4	EMISSION CONTROL INFORMATION LABEL	1-9
SPECIAL TOOLS/COMMON TOOLS	1-5	MAINTENANCE SCHEDULE	1-10

## GENERAL SAFETY

### WARNING

*If the engine must be running to do some work, make sure the area is well-ventilated. Never run the engine in a closed area. The exhaust contains poisonous carbon monoxide gas.*

### WARNING

*Gasoline is extremely flammable and is explosive under certain conditions. Do not smoke or allow flames or sparks in your working area.*

### WARNING

- *The battery electrolyte contains sulfuric acid. Protect your eyes, skin and clothing. In case of contact, flush thoroughly with water and call a doctor if your eyes were exposed.*

### WARNING

- *The battery generates hydrogen gas which can be highly explosive. Do not smoke or allow flames or sparks near the battery, especially while charging it.*

## SERVICE RULES

1. Use genuine HONDA or HONDA-recommended parts and lubricants or their equivalent. Parts that do not meet HONDA's design specifications may damage the motorcycle.
2. Use the special tools designed for this product.
3. Install new gaskets, O-rings, cotter pins, lock plates, etc. when reassembling.
4. When torquing bolts or nuts, begin with larger-diameter or inner bolt first, and tighten to the specified torque diagonally, unless a particular sequence is specified.
5. Clean parts in cleaning solvent upon disassembly. Lubricate any sliding surfaces before reassembly.
6. After reassembly, check all parts for proper installation and operation.
7. Use only metric tools when servicing this motorcycle. Metric bolts, nuts, and screws are not interchangeable with English fasteners. The use of incorrect tools and fasteners may damage the motorcycle.



**SPECIFICATIONS**

	Item	Metric	English	
DIMENSIONS	Overall length	2,185 mm	86.0 in	
	Overall width	865 mm	34.1 in	
	Overall height	1,175 mm	46.3 in	
	Wheel base	1,455 mm	57.3 in	
	Seat height	810 mm	31.9 in	
	Foot peg height	335 mm	13.2 in	
	Ground clearance	150 mm	5.9 in	
	Dry weight	200 kg	441 lbs	
FRAME	Type	Diamond		
	F. suspension and travel	Telescopic fork, 139.5 mm (5.5 in)		
	R. suspension and travel	Swing arm, 85 mm (3.3 in)		
	F. tire size and air pressure	3.25S19-4PR 1.75 kg/cm <sup>2</sup> (24 psi)		
	R. tire size and air pressure	3.75S18-4PR 2.0/2.5 kg/cm <sup>2</sup> (28/36 psi)		
	F. brake	Disc brake		
	R. brake	Internal expanding shoes		
	Fuel capacity	17 lit.	4.5 US gal 3.7 Imp gal	
	Fuel reserve capacity	3.5 lit.	0.9 US gal 0.8 Imp gal	
	Caster angle	63° 30'		
	Trail length	100 mm	3.9 in	
	Front fork oil capacity	135 cc (to fill if dry)	4.7 oz	
ENGINE	Type	Liquid cooled 4 stroke OHV engine		
	Cylinder arrangement	2 cylinder transverse V		
	Bore and stroke	78 x 52 mm	3.071 x 2.047 in	
	Displacement	496 cc	30.3 cu. in	
	Compression ratio	10:1		
	Valve train	Chain driven camshaft and push rod		
	Oil capacity	3.0 lit.	3.2 US qt 2.6 Imp qt	
	Lubrication system	Forced pressure and wet sump		
	Cooling system capacity	2.0 lit.	0.52 US gal	
	Cylinder compression	12 kg/cm <sup>2</sup>	171 psi	
	Intake valve	Opens	6° BTDC (at 1 mm lift), 75° BTDC (at 0 lift)	
		Closes	46° ABDC (at 1 mm lift), 115° ABDC (at 0 lift)	
	Exhaust valve	Opens	46° BBDC (at 1 mm lift), 111° BBDC (at 0 lift)	
		Closes	6° ATDC (at 1 mm lift), 71° ATDC (at 0 lift)	
	Valve clearance	IN.	0.08 mm	0.003 in
		EX.	0.10 mm	0.004 in
Idle speed	1,100 ± 100 rpm			
CARBURETION	Carburetor type	CV type, 35 mm (1.38 in) venturi bore		
	Setting number	VB26A		
	Pilot screw initial setting	See page 4-10		
	Float level	15.5 mm	0.61 in	





	Item	Metric	English	
DRIVE TRAIN	Clutch	Wet. multi-plate		
	Transmission	5-speed. constant mesh		
	Primary reduction ratio	2.242 (74/33)		
	Gear ratio I	2.733 (41/15)		
	Gear ratio II	1.850 (37/20)		
	Gear ratio III	1.416 (34/24)		
	Gear ratio IV	1.148 (31/27)		
	Gear ratio V	0.931 (27/29)		
	Final reduction ratio	3.091 (34/11)		
	Gear shift pattern	Left foot operated return system		
	Final gear oil capacity	170 ± 10 cc	5.7 ± 0.3 US oz	
ELECTRICAL	Ignition	C.D.I.		
	Ignition advance	"F" mark	15° BTDC	
		Maximum advance	37° ± 3° BTDC	
		RPM from "F" to max. advance	1,750 ~ 6,000 rpm	
	Starting system	Starter motor		
	Alternator	Three phase A.C.G. 12 V 0.17 kw/5,000 rpm		
	Battery capacity	12 V - 14 AH		
	Spark plug (STD)	USA model	ND X24ES-U	NGK D8EA
		Canadian model	ND X24ESR-U	NGK DR8ES-L
	Spark plug gap	0.6 ~ 0.7 mm	0.024 ~ 0.028 in.	
LIGHTS	Headlight (low/high beam)	40/50 watt		
	Tail/stop light	8/27 watt 3/32 cp SAE No. 1157		
	Turn signal light	Front	23/23 watt 32/32 cp SAE No.	FRONT 1034
		Rear		REAR 1073
	Meter light	Speedometer	3.4 watt 2 cp SAE No. 57	
		Tachometer		
	Neutral indicator light	3.4 watt 2 cp SAE No. 57		
	Turn signal indicator light	3.4 watt 2 cp SAE No. 57		
	High beam indicator light	3.4 watt 2 cp SAE No. 57		
	Oil pressure warning light	3.4 watt 2 cp SAE No. 57		
Parking light	8 watt 3 cp SAE No. 1034			





## TORQUE VALUES

### <ENGINE>

Item	Q'ty	Thread Dia. (mm)	Torque Values	
			kg-m	ft-lb
Crankshaft cap	7	8	2.0 - 2.4	14 - 17
Connecting rod cap	4	8	2.8 - 3.2	20 - 23
Cylinder head	8	12	5.0 - 5.5	36 - 40
Valve adjusting nut	8	6	1.5 - 1.8	11 - 13
Flywheel	1	12	8.0 -10.0	58 - 72
Clutch center	1	20	8.0 -10.0	58 - 72
Primary drive gear	1	12	8.0 - 9.5	58 - 69
Starting clutch outer	3	8	1.8 - 2.5	13 - 18
Cooling fan	1	8	2.0 - 2.5	14 - 18
Cam sprocket boss	1	20	8.0 -10.0	58 - 72
Cam sprocket	2	7	1.6 - 2.0	12 - 14
Change pedal	1	6	1.0 - 1.4	7 - 10
Radiator drain bolt	1	12	0.15- 0.30	1.1- 2.2

### <FRAME>

Item	Q'ty	Thread Dia. (mm)	Torque Values	
			kg-m	ft-lb
Steering stem nut	1	24	9.0 -12.0	65 - 87
Handlebar top bridge	2	7	0.9 - 1.3	7 - 9
Handlebar lock	2	6	1.0 - 1.4	7 - 10
Handlebar holder	4	8	2.5 - 3.0	18 - 22
Front fork bottom bridge	2	8	1.8 - 2.5	13 - 18
Front and rear axles	1	14	5.5 - 6.5	40 - 47
Front axle holder	4	8	1.8 - 2.5	13 - 18
Engine hanger bolt	4	10	3.5 - 4.5	25 - 33
Engine hanger bolt	1	12	6.0 - 7.0	43 - 51
Final drive flange nut	3	10	3.5 - 4.5	25 - 33
Rear brake torque link	1	8	1.5 - 2.3	11 - 17
Rear shock absorber	4	10	3.0 - 4.0	22 - 29
Foot peg	2	10	3.0 - 4.0	22 - 29
Swing arm pivot nut	1	23	8.0 -12.0	58 - 87
Front brake disc	5	8	2.7 - 3.3	20 - 24
Gear case rear fork	3	10	3.5 - 4.5	25 - 33
Swing arm pivot bolt	1	23	0.8 - 1.2	6 - 9
Front caliper	2	10	3.0 - 4.0	22 - 29

Torque specifications listed above are important tightening points. Others should be torqued to standard torques below.

### ● STANDARD TORQUE VALUES

Item	Torque Values kg-m (ft-lb)	Item	Torque Values kg-m (ft-lb)
5 mm bolt and nut	0.45-0.6 ( 3- 4)	5 mm screw	0.35-0.5 ( 3- 4)
6 mm bolt and nut	0.8 -1.2 ( 6- 9)	6 mm screw	0.7 -1.1 ( 5- 8)
8 mm bolt and nut	1.8 -2.5 (13-18)	6 mm flange bolt and nut	1.0 -1.4 ( 7-10)
10 mm bolt and nut	3.0 -4.0 (22-29)	8 mm flange bolt and nut	2.0 -3.0 (14-21)
12 mm bolt and nut	5.0 -6.0 (36-43)	10 mm flange bolt and nut	3.0 -4.0 (22-29)





**SPECIAL TOOLS / COMMON TOOLS**

• SPECIAL TOOLS

Tool Name	Tool No.	Appropriation List (Common Tool – Special Tool)	
Torx driver bit	07703-0010100	Local purchase item T40 torx bit or socket	
Piston slider	07755-0010000	Local purchase item ratchet type	
* Socket wrench (27 x 17 mm)	07907-4150000		
Final retainer wrench	07910-3710100		
* Retainer B wrench	07910-4150000		
Snap ring pliers	07914-3230001		
Hollow set wrench (6 mm)	07917-3230000	Local purchase item	
Socket bit (10 mm)	07917-3710000	Local purchase item	
* Clutch center holder	07923-4150000		
* Gear holder	07924-4150000		
* Crank cap puller	07935-4150000		
Bearing remover head (20 mm)	07936-3710600		
(Bearing remover handle)	(07936-3710100)		
(Bearing remover weight)	(07936-3710200)		
Bearing remover head	07936-3710600		
* Pivot bearing outer remover	07936-4150000		
* Piston remover	07941-4150000		
* Valve guide driver attachment	07943-4150000		
Ball race driver (BOTTOM)	07945-3330300		
* Crank cap driver	07945-4150100		
* Mechanical seal driver attachment	07945-4150200		
Mechanical seal pilot	07945-4150301		
Ball race driver (TOP)	07946-3290000	Ball race remover/installer	07946-3710400
Steering stem driver	07946-3710600		
Ball race remover	07953-3330000	Ball race/cone driver	07946-3710600
* Ring gear Dis/Assembly tool set	07965-4150000		
(Ring gear center guide)	(07965-4150100)		
(Dis/Assembly tool A)	(07965-4150200)		
(Dis/Assembly tool B)	(07965-3710200)		
(Dis/Assembly tool C)	(07965-3710300)		
* Main bearing Dis/Assembly tool	07973-4150000		
Valve guide reamer (6.6 mm)	07984-6110000		
* Preload inspection tool	07998-4150000		
* Inspection plug	07999-4150000		
Special tool case	07797-2920300		
Vacuum gauge tester	07404-0020000		
(Vacuum gauge attachment)	(07510-3000100)		
* Tire lever set (for comstar wheel)	07772-0020000		
(Tire lever)	(07772-0020100)		
(Rim protector)	(07772-0020200)		

- The tools asterisked (\*) are included in the "SPECIAL TOOL SET B 07900-4150101" and these are new for CX500.
- The tools starred (\*) are designed for comstar wheels.

• COMMON TOOLS

Tool Name	Tool No.	Appropriation List (Common Tool – Special Tool)	
Float level gauge	07401-0010000		
Pin spanner	07702-0010000		
Tappet adjusting wrench (10 x 12 mm)	07708-0030200	Pin spanner (46 mm)	07902-2400000
Tappet adjusting (B)	07708-0030400		Tappet adjusting wrench set
Retainer wrench B	07710-0010200	(Tappet adjusting wrench (10 mm))	07908-3640100
Retainer wrench body	07710-0010401	(Tappet adjusting (A))	07908-3290100
Lock nut wrench socket (26 x 29 mm)	07716-0020201	Retainer wrench	07910-3230101
Lock nut wrench socket (30 x 32 mm)	07716-0020400		
Extension bar & handle	07716-0020500		
Flywheel & rotor puller	07733-0010000		
Rotor puller	07733-0020000		
Valve guide remover (6.6 mm)	07742-0010200		
Pin driver (3.5 mm)	07744-0010300		
Bearing driver outer (42 x 47 mm)	07746-0010300		
Bearing driver outer (52 x 55 mm)	07746-0010400		
Bearing driver pilot (15 mm)	07746-0040300		
Bearing driver pilot (20 mm)	07746-0040500		
Bearing driver pilot (22 mm)	07746-0041000		
Bearing driver pilot (25 mm)	07746-0040600		
Bearing driver pilot (30 mm)	07746-0040700		
Front fork oil seal driver body	07747-0010100		
Front fork oil seal attachment (D)	07747-0010500	Fork seal driver	07947-3330000
Bearing driver handle (A)	07749-0010000	Driver handle attachment	
Valve spring compressor	07757-0010000	(Not to be used with common tools)	07949-6110000
Rear shock absorber compressor	07759-3290001	Valve spring compressor	07957-3290001

- The tools asterisked (\*) indicate those which are not found in special tools.
- See the "NEW MOTORCYCLE COMMON TOOL LIST" at the back of this manual.

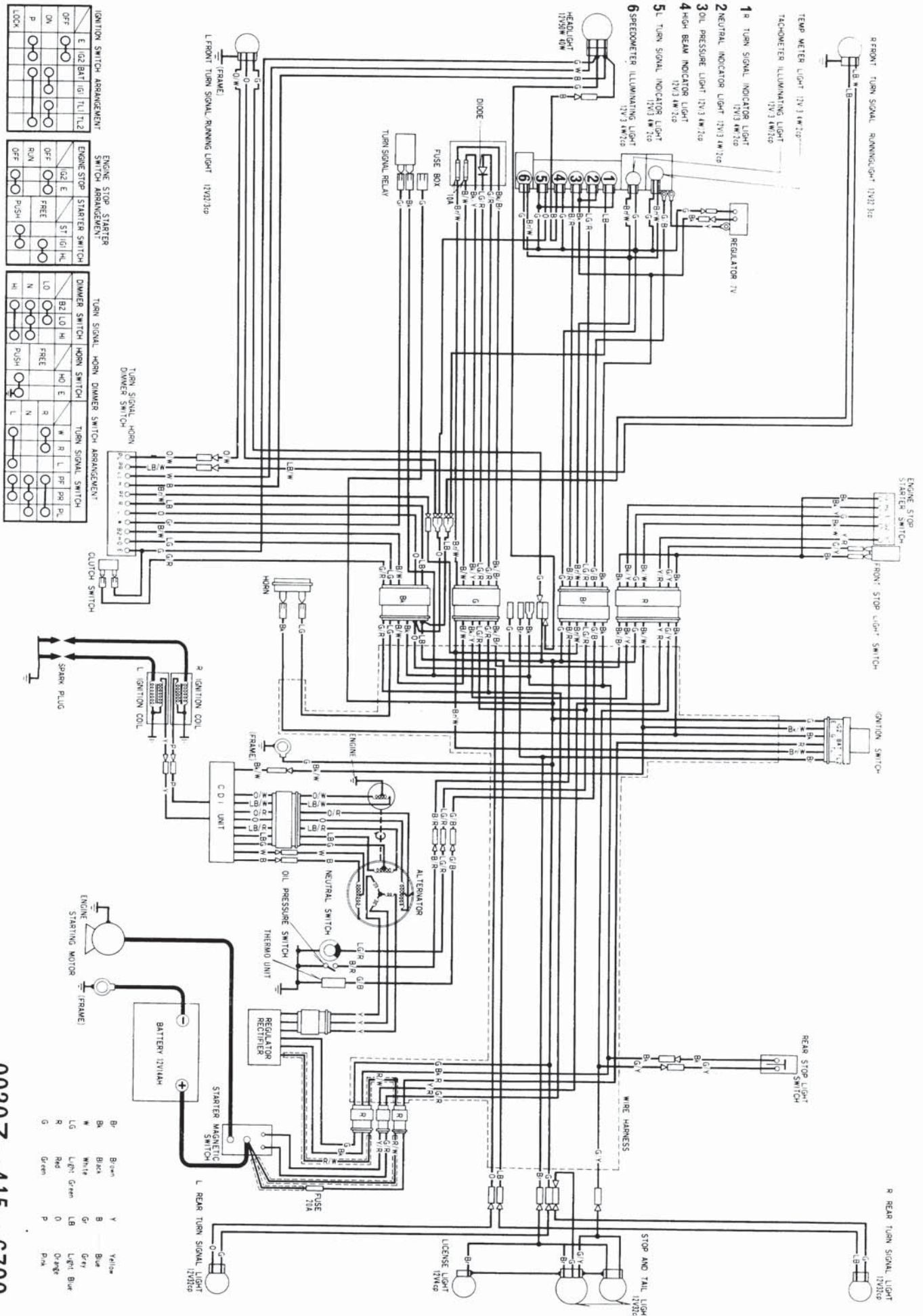

IGNITION SWITCH ARRANGEMENT

OFF	ON	LOOK
E	I2	BAT
I1	I2	TU
I1, I2		

ENGINE STOP - STARTER SWITCH ARRANGEMENT

OFF	ON	P
I2	E	
ST	I1	HL

TURN SIGNAL, HORN SWITCH ARRANGEMENT

LO	HI	HO	E
B2	I1	I2	

TURN SIGNAL, HORN DIMMER SWITCH ARRANGEMENT

LO	HI	HO	E
B2	I1	I2	

CLUTCH SWITCH

ON	OFF
C	

SPARK PLUG

SPARK PLUG

BATTERY 12V/14AH

+	-

WIRE COLOR CODES

Br	Brown	Y	Yellow
Bk	Black	B	Blue
W	White	Gr	Grey
Lg	Light Green	LB	Light Blue
R	Red	O	Orange
G	Green	Pk	Pink

0030Z-415-6700



# CABLE & HARNESS ROUTING

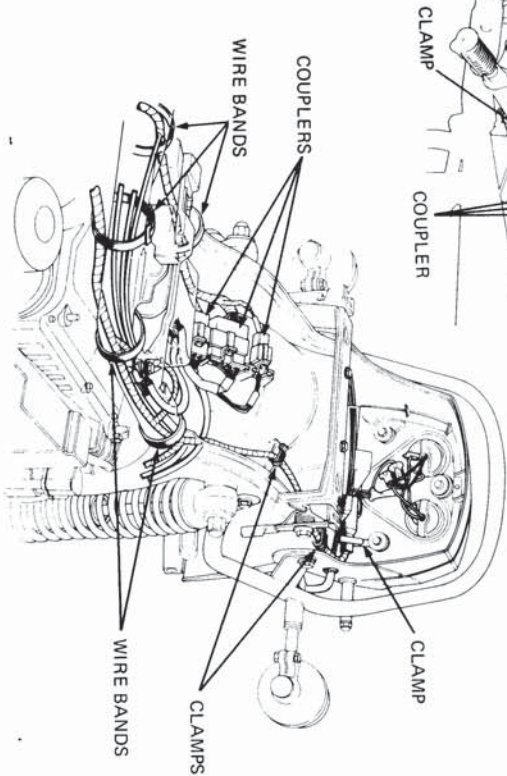
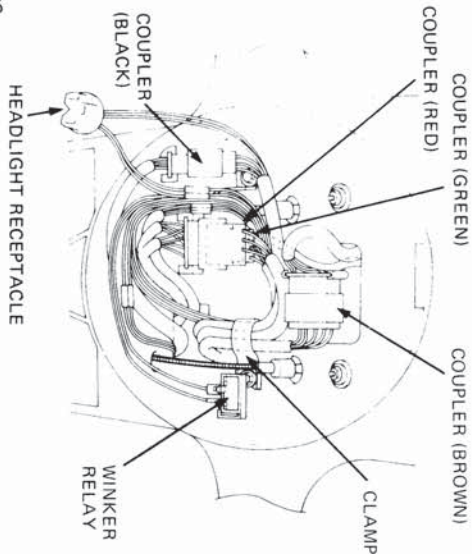
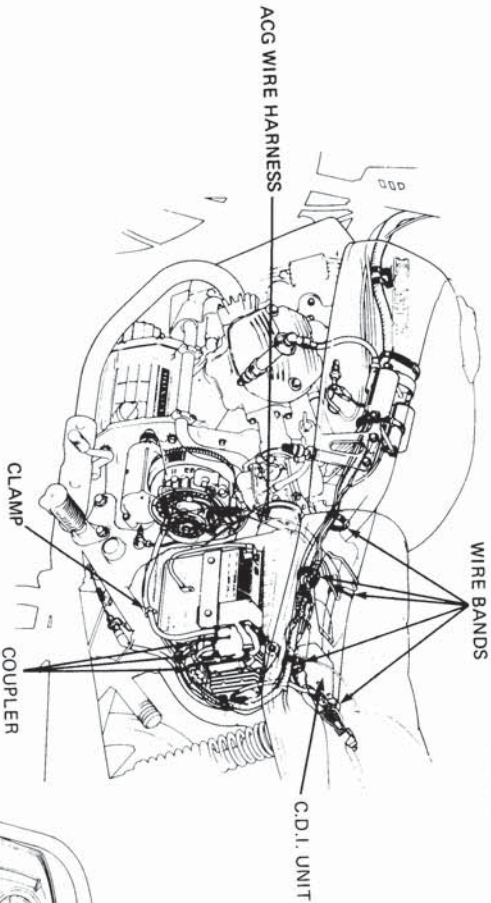
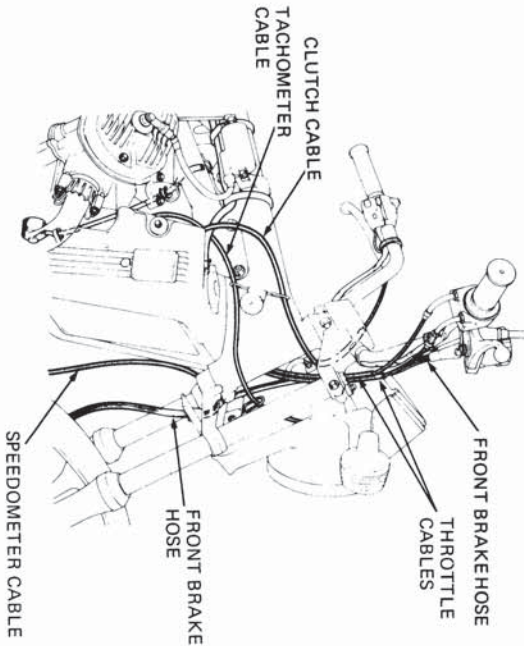
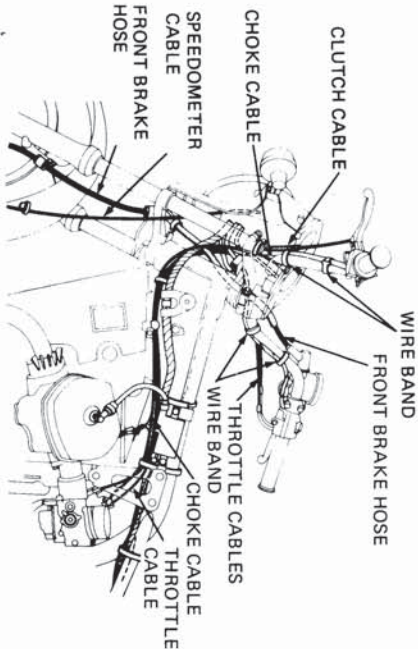
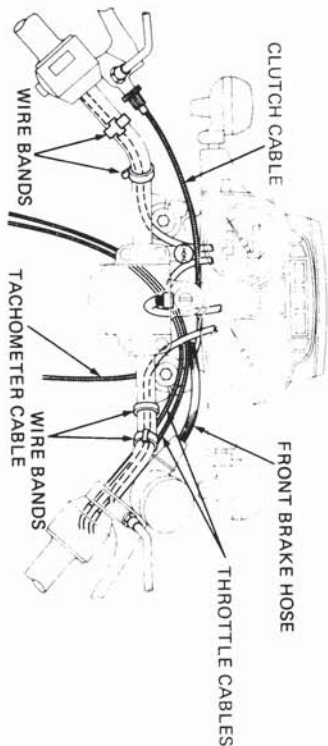



## EMISSION CONTROL SYSTEM

The CX500 is equipped with two emission control systems.

- **EXHAUST EMISSION CONTROL SYSTEM**  
The exhaust emission control system is composed of a factory pre-set carburetor. No adjustment should be made except to the idle speed with the throttle stop screw.
- **CRANKCASE EMISSION CONTROL SYSTEM**  
The engine is equipped with a "Closed System" to prevent crankcase emission from entering the atmosphere. Blow-by gas is returned to the combustion chamber through the breather tube, separator and intake pipe.

### CRANKCASE EMISSION CONTROL SYSTEM

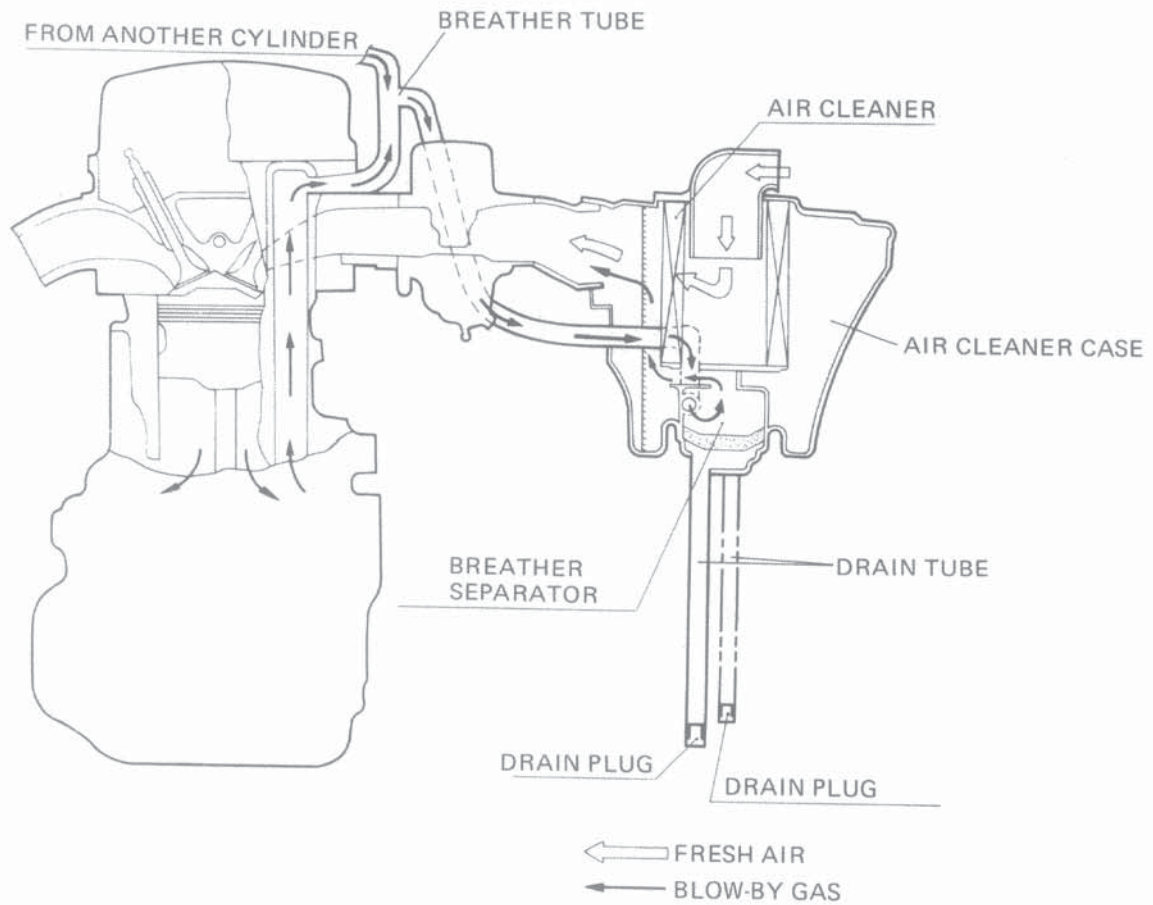



**EMISSION CONTROL INFORMATION LABEL**

CX500's manufactured after December 31, 1977 have an Emission Control Information label on the frame as shown. It contains basic tune-up specifications for CX500's manufactured after December 31, 1977. Refer to this Shop Manual for more details.

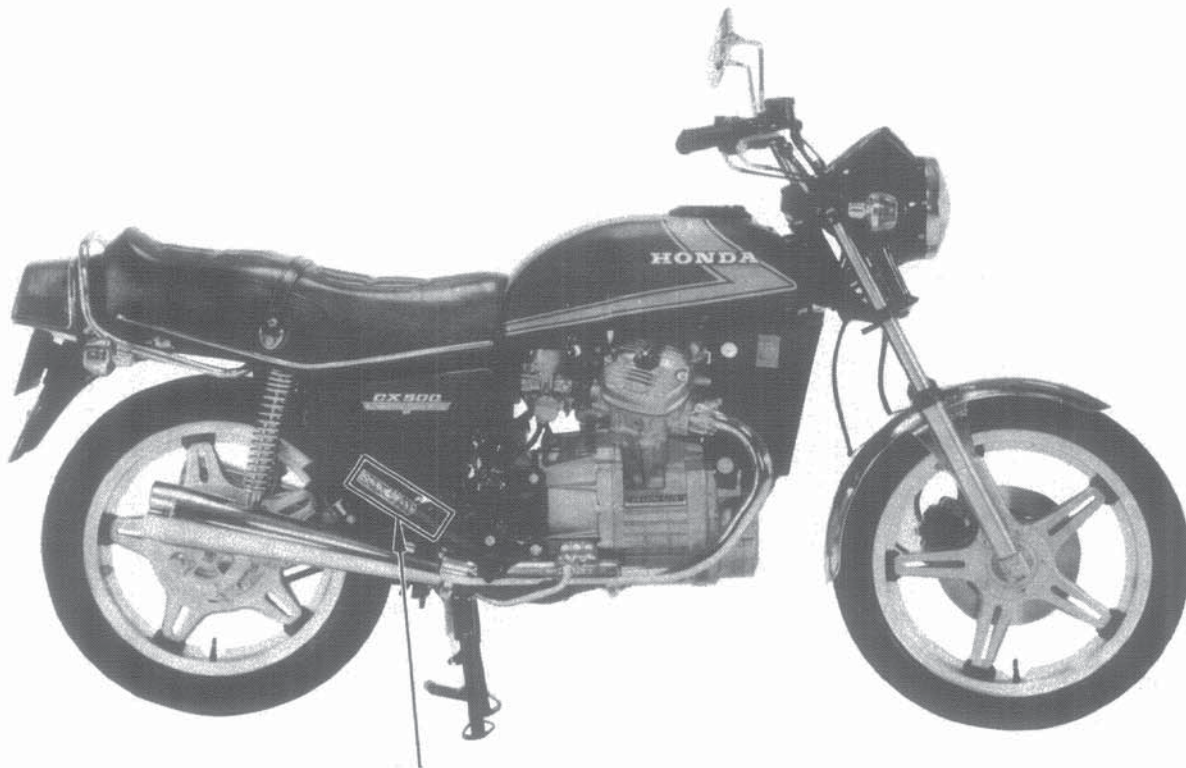

EMISSION CONTROL INFORMATION LABEL



**MAINTENANCE SCHEDULE**

Perform the PRE-RIDE INSPECTION in the Owner's Manual at every maintenance period.

I : INSPECT, CLEAN, ADJUST, LUBRICATE OR REPLACE IF NECESSARY.

C : CLEAN

R : REPLACE

A : ADJUST

L : LUBRICATE

ITEM	FREQUENCY	WHICHEVER OCCURS FIRST ↓ EVERY	ODOMETER READING [NOTE (3)]								REFER TO
			600 mi. (1,000 km)	3,600 mi. (6,000 km)	7,200 mi. (12,000 km)	10,800 mi. (18,000 km)	14,400 mi. (24,000 km)	18,000 mi. (30,000 km)	21,600 mi. (36,000 km)		
EMISSION RELATED ITEMS	ENGINE OIL	YEAR	R		R		R		R	Page 2- 2	
	ENGINE OIL FILTER	YEAR	R		R		R		R	Page 2- 2	
	CRANKCASE BREATHER	NOTE (1)		C	C	C	C	C	C	Page 3- 3	
	AIR CLEANER	NOTE (2)		C	R	C	R	C	R	Page 3- 2	
	* FUEL LINES				I		I		I	Page 3- 3	
	SPARK PLUGS			I	R	I	R	I	R	Page 3- 3	
	* VALVE CLEARANCE		I	I	I		I		I	Page 3- 4	
	* CAM CHAIN TENSION		A	A	A	A	A	A	A	Page 3- 5	
	* THROTTLE OPERATION		I		I		I		I	Page 3- 5	
	* CARBURETOR-IDLE SPEED		I	I	I	I	I	I	I	Page 3- 6	
	* CARBURETOR-CHOKE				I		I		I	Page 3- 6	
	* CARBURETOR-SYNCHRONIZE		I		I		I		I	Page 3- 7	
	* COOLANT				I		I		R	Page 3- 8 9- 3	
	* COOLING SYSTEM, HOSES		I		I		I		I	Page 3- 8	
	* RADIATOR CORE				I		I		I	Page 3- 8	
NON-EMISSION RELATED ITEMS	* DRIVE SHAFT JOINT				L		L		L	Page 2- 3	
	* FINAL DRIVE LUBRICANT				I		I		R	Page 2- 3	
	BATTERY	MONTH	I	I	I	I	I	I	I	Page 3- 9	
	BRAKE FLUID (FRONT)	MONTH I 2 YEARS R	I	I	I	I	I	I	*R	Page 3- 9	
	BRAKE SHOE/PAD WEAR			I	I	I	I	I	I	Page 3-11	
	BRAKE SYSTEM			I	I	I	I	I	I	Page 3-11	
	* BRAKE LIGHT SWITCH			I	I	I	I	I	I	Page 3-12	
	* HEADLIGHT AIM			I	I	I	I	I	I	Page 3-13	
	CLUTCH FREE PLAY			I	I	I	I	I	I	Page 3-13	
	SIDE STAND				I		I		I	Page 3-14	
	* SUSPENSION			I	I	I	I	I	I	Page 3-14	
	* NUTS, BOLTS, FASTENERS			I	I	I	I	I	I	Page 3-15	
** WHEELS			I	I	I	I	I	I	Page 3-15		
** STEERING HEAD BEARING			I	I	I	I	I	I	Page 3-15		

\*\* IN THE INTEREST OF SAFETY, WE RECOMMEND THESE ITEMS BE SERVICED ONLY BY AN AUTHORIZED HONDA DEALER.

\* SHOULD BE SERVICED BY AN AUTHORIZED HONDA DEALER, UNLESS THE OWNER HAS PROPER TOOLS AND IS MECHANICALLY QUALIFIED.

NOTES: (1) More frequent service may be required when ridden in rain, ridden at full throttle openings, dropped or washed often. Service if deposit level can be seen in the transparent section of drain tubes.

(2) More frequent service may be required when riding in dusty areas.

(3) For higher odometer readings, repeat at the frequency interval established here.





GENERAL INFORMATION

LUBRICATION DIAGRAM

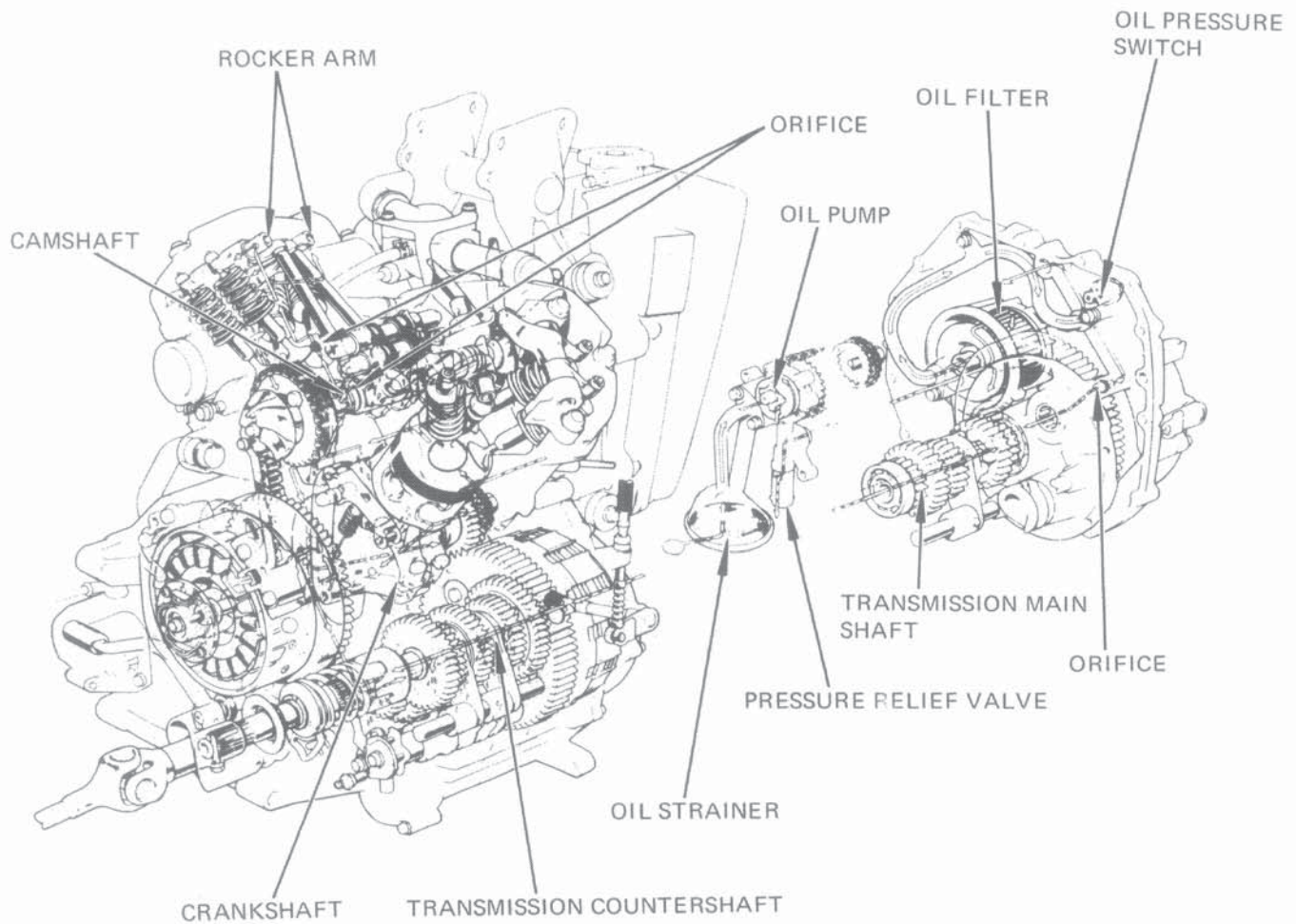



SERVICE INFORMATION	2-1
TROUBLESHOOTING	2-1
ENGINE OIL LEVEL CHECK	2-2
ENGINE OIL & OIL FILTER CHANGE	2-2
FINAL GEAR OIL CHECK/REPLACEMENT	2-3
DRIVE SHAFT JOINT LUBRICANT	2-3
LUBRICATION POINTS	2-4

## SERVICE INFORMATION

### • WORKING PRACTICE

Oil pump	Refer to Section 7.
Oil pressure relief valve	Refer to Section 7.
Oil strainer	Refer to Section 7.

### • SPECIFICATIONS

Oil capacity	3.0 liters (3.2 U.S. qt.) at engine assembly; 2.5 liters (2.6 U.S. qt.) at oil change
Oil	HONDA 4-STROKE Oil or equivalent, rated SAE 10W-40, grade SE
Oil pump delivery	9.4 ± 1 liter/3,000 rpm/min.

## TROUBLESHOOTING

### Oil Level Too Low:

1. Normal oil consumption
2. External oil leaks
3. Worn piston rings

### Oil Contamination

1. Oil or filter not changed often enough
2. Defective head gasket

### Low Oil Pressure

1. Faulty warning light switch
2. Pressure relief valve stuck open
3. Plugged oil pick-up screen
4. Oil pump worn

### High Oil Pressure:

1. Pressure relief valve stuck closed
2. Plugged oil filter, gallery, or metering orifice
3. Incorrect oil being used

### No Oil Pressure

1. Oil level too low
2. Oil pump drive chain broken
3. Faulty oil pump





## ENGINE OIL LEVEL CHECK

Place the motorcycle on its center stand. Check the oil level with the filler cap dipstick after 2–3 minutes. Do not screw in the cap when making this check. If the level is below the lower level mark on the dipstick, fill to the upper level mark with the recommended oil.

## ENGINE OIL & OIL FILTER CHANGE

### NOTE

Engine oil change is performed with the engine at normal operating temperature and vehicle on its center stand to ensure complete and rapid draining.

Remove the oil filler cap.

Remove the drain plug to drain oil from the engine.

### NOTE

Crank the engine for 2–3 seconds to drain any residual oil.

Screw out the oil filter bolt and remove the oil filter element from the oil filter case. Check operation of the bypass valve in the oil filter bolt.

Install a new oil filter element and retighten the oil filter bolt.

### NOTE

- Make sure that the o-rings on the filter bolt and the oil filter cover are not damaged and are in good condition.
- Torque the oil filter bolt.

**TORQUE: 2.0–2.5 kg-m (14–18 ft-lb)**

Reinstall the drain plug.

Making sure the sealing washer is in good condition.

Fill the engine with 2.5 liters (2.6 U.S. qt) of recommended oil.

### RECOMMENDED OIL:

Use HONDA 4-STROKE OIL or equivalent.

API Service Classification : SE  
 General, all temperatures : SAE 10W-40

Above 15°C/59°F : SAE 30  
 0°C/32°F - 15°C/59°F : SAE 20 or 20W  
 Below 0°C/32°F : SAE 10W

Stop the engine, make sure that the oil level is at the upper level mark, and there are no oil leaks.

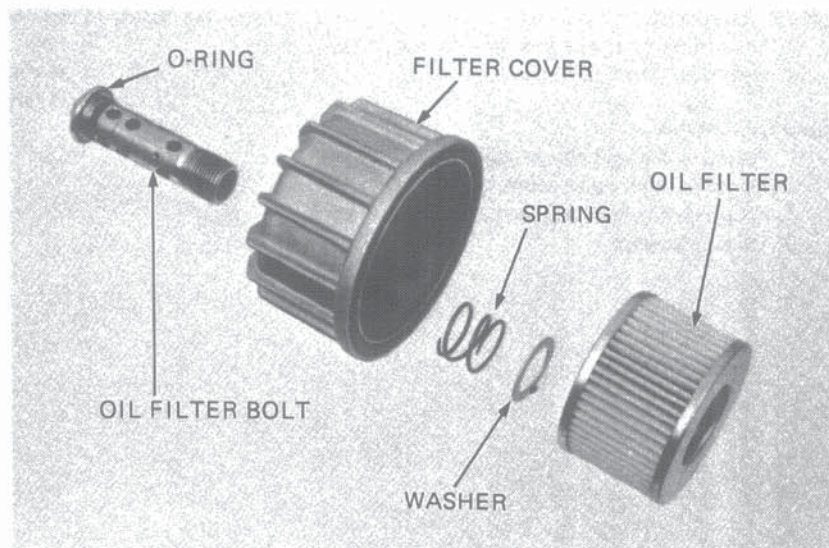
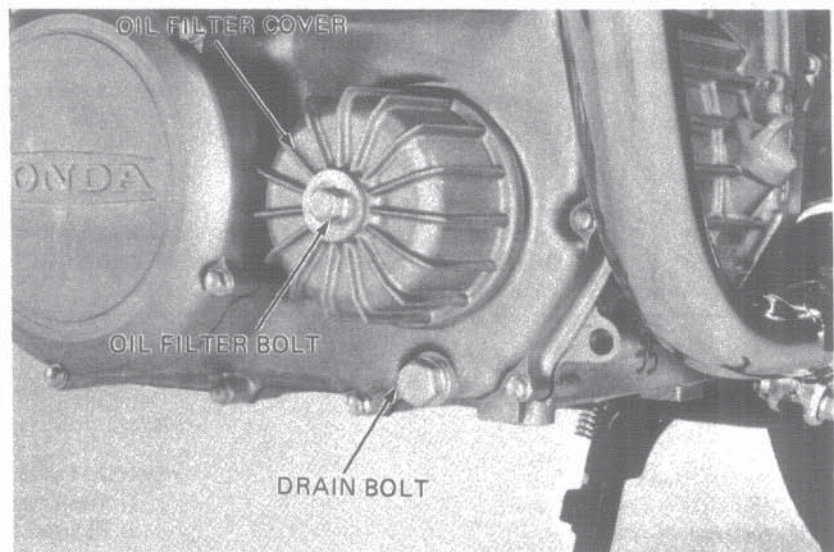
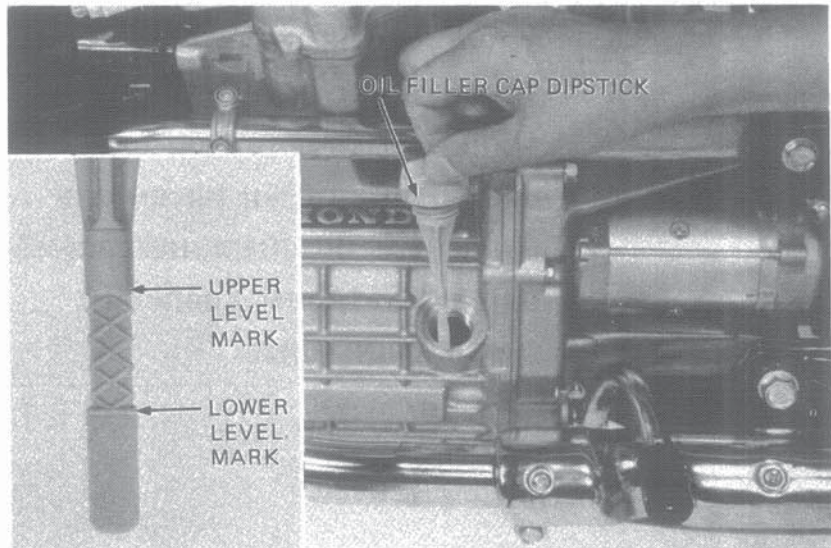





## FINAL DRIVE GEAR OIL CHECK/ REPLACEMENT

### • OIL LEVEL CHECK

Place the motorcycle on its center stand.  
Remove the oil filler cap.  
Check that the final gear case is filled up to the lower edge of the oil filler cap hole.

#### NOTE

If the level is low, check for leaks. Pour fresh oil through the oil filler opening until it reaches the lower edge of the opening.

### • OIL REPLACEMENT

Remove the oil filler cap.  
Remove the drain bolt to drain all oil from the final gear case.  
Reinstall the drain bolt securely.  
Fill the gear case with the recommended oil up to the correct level.

**OIL CAPACITY: 170 cc (5.7 US oz)**  
**RECOMMENDED OIL: HYPOID GEAR OIL**  
**SAE 90 (Above 5°C, 41°F)**  
**SAE 80 (Below 5°C, 41°F)**

## DRIVE SHAFT JOINT

Pump multipurpose grease through the drive shaft joint grease fitting LITHIUM-BASED MULTIPURPOSE GREASE.

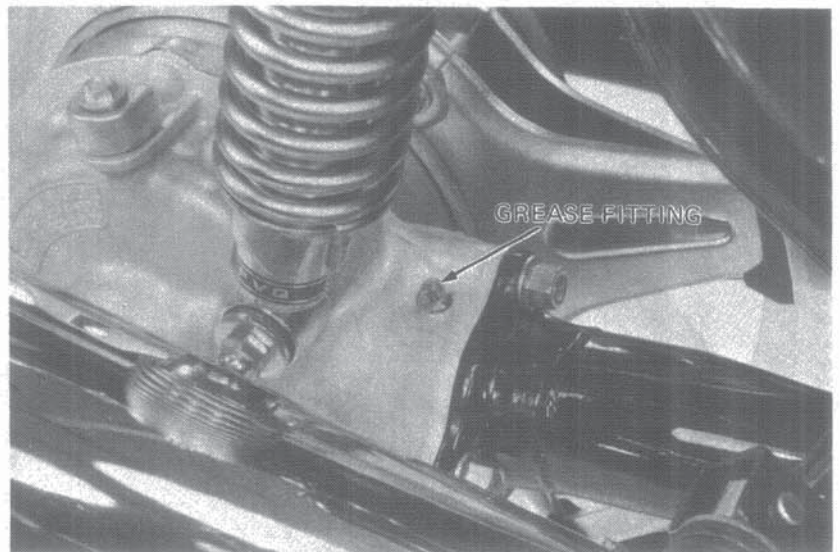
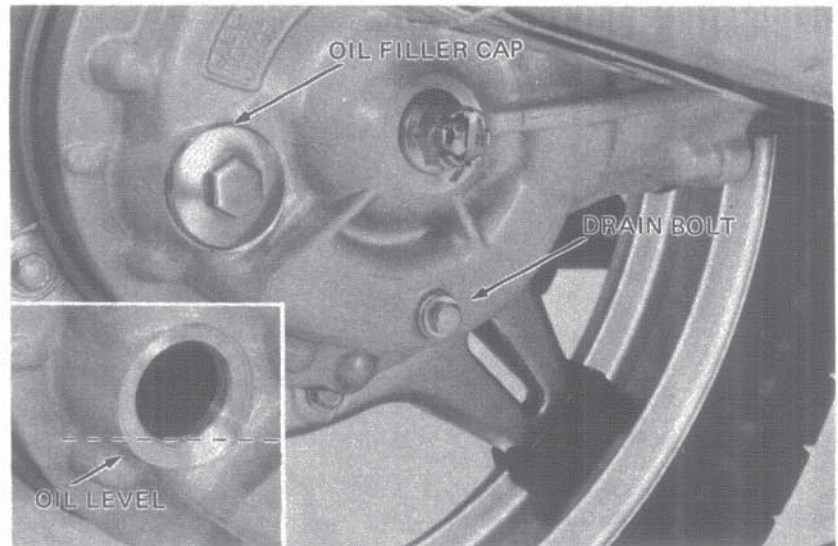





**LUBRICATION POINTS**

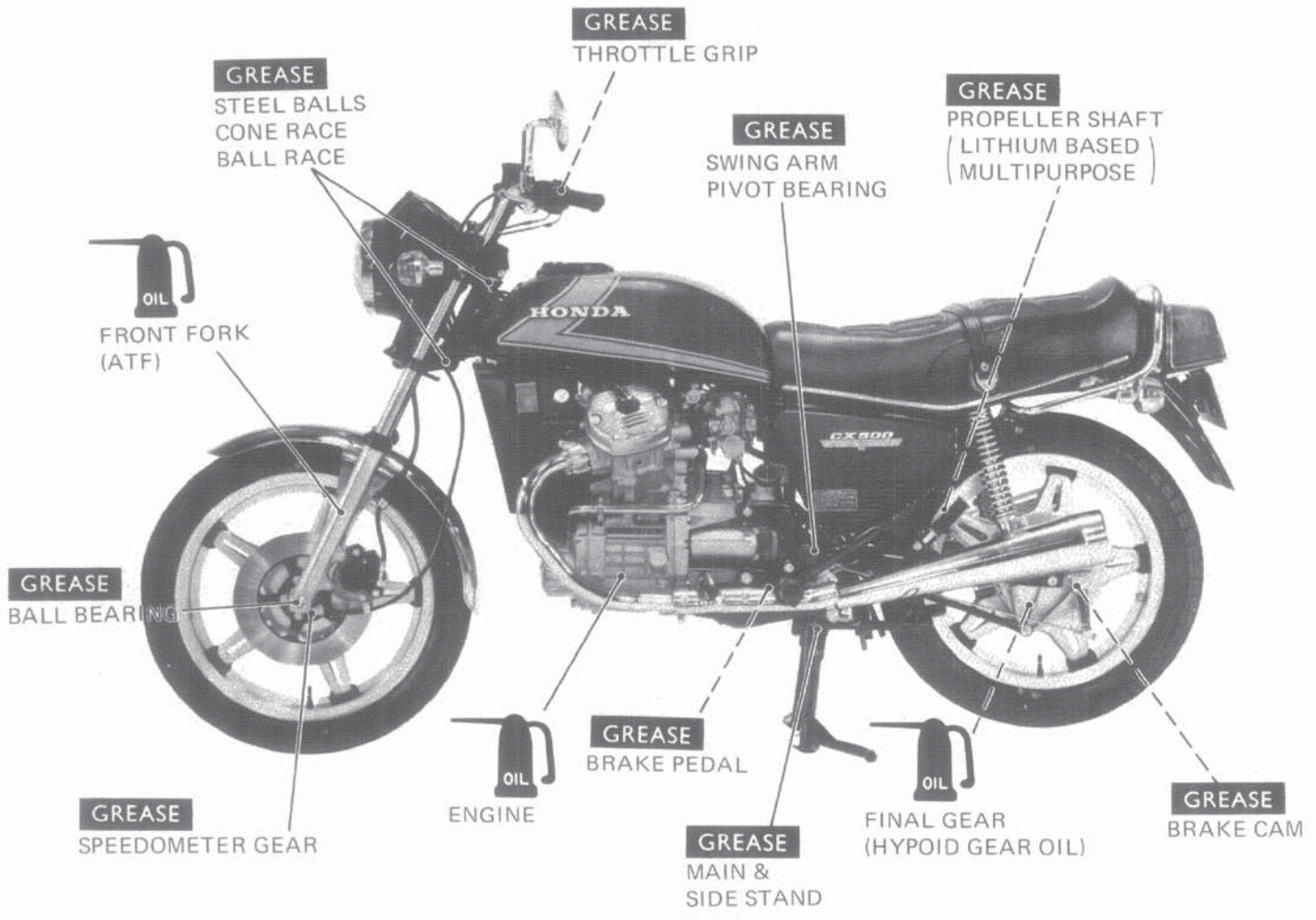



ENGINE		FRAME	
SERVICE INFORMATION	3-1	BATTERY	3-9
AIR CLEANER	3-2	BRAKE FLUID LEVEL	3-9
CRANKCASE BREATHER	3-3	BRAKE FLUID	3-10
FUEL LINE	3-3	BRAKE SYSTEM	3-11
SPARK PLUG	3-3	HEADLIGHT AIM	3-13
VALVE CLEARANCE	3-4	CLUTCH FREE PLAY	3-13
CAM CHAIN	3-5	SIDE STAND	3-14
THROTTLE OPERATION	3-5	SUSPENSION	3-14
IDLE SPEED	3-6	WHEELS	3-15
CARBURETOR CHOKE	3-6	STEERING HEAD BEARING	3-15
CARBURETOR SYNCHRONIZATION	3-7	NUTS, BOLTS, FASTENERS	3-15
COOLANT	3-8		
COOLING SYSTEM HOSES	3-8		
RADIATOR CORE	3-8		

## SERVICE INFORMATION

### • WORKING PRACTICE

ENGINE OIL LEVEL	Refer to Page 2-2
ENGINE OIL & OIL FILTER CHANGE	Refer to Page 2-2
FINAL DRIVE LUBRICANT	Refer to Page 2-3
DRIVE SHAFT JOINT	Refer to Page 2-3

### • SPECIFICATIONS

#### ENGINE

Spark plug gap: 0.6-0.7 mm (0.024-0.028 in.)

Spark plug type: USA model

Canadian model

ND X24ESR-U, NGK DR8ES-L

For cold climate below 5°C (41°F)		Standard		For extended high speed riding	
ND	NGK	ND	NGK	ND	NGK
X22ES-U	D7EA	X24ES-U	D8EA	X27ES-U	D9EA

#### ENGINE

Ignition timing.	
"FL" mark	: 15° BTDC at 1,100 rpm
Ignition advance	: 37° BTDC at 5,500-6,000 rpm
Valve clearance	
IN	: 0.08 mm (0.003 in.)
EX	: 0.10 mm (0.004 in.)
Throttle free play	: 2-6 mm (0.08-0.24 in.)
Idle speed	: 1,100 ± 100 rpm
Vacuum pressure difference	
between carburetors	: 40 mm (1.6 in.) Hg
Fast idle speed	: 1,500-2,500 rpm
Compression	: 12 ± 2 kg/cm <sup>2</sup> (171 ± 28 psi.)
Clutch free play	: 10-20 mm (3/8-3/4 in.)

### • TORQUE VALUES

Front axle nut	: 5.5-6.5 kg-m (40-47 ft-lbs)
Front axle nut holder	: 1.8-2.5 kg-m (13-18 ft-lbs)
Rear axle nut	: 5.5-6.5 kg-m (40-47 ft-lbs)

#### CHASSIS

Rear brake pedal free play	: 20-30 mm (3/4-1-1/4 in.)
Tire pressures:	
Rider only:	
Front	: 1.75 kg/cm <sup>2</sup> (25 psi.)
Rear	: 2.00 kg/cm <sup>2</sup> (28 psi.)
Rider and passenger:	
Front	: 1.75 kg/cm <sup>2</sup> (25 psi.)
Rear	: 2.50 kg/cm <sup>2</sup> (36 psi.)





## AIR CLEANER

Remove the seat.  
Remove the air cleaner cover by turning it counterclockwise.

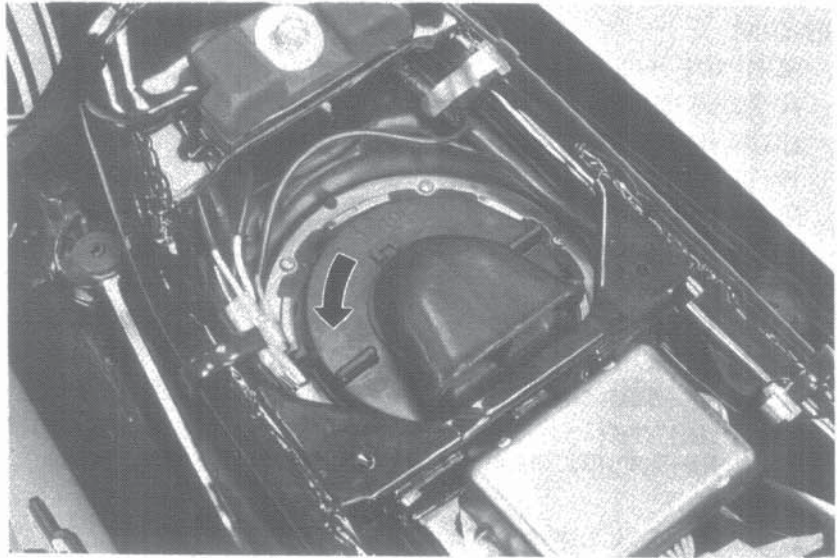

Remove the air cleaner element.

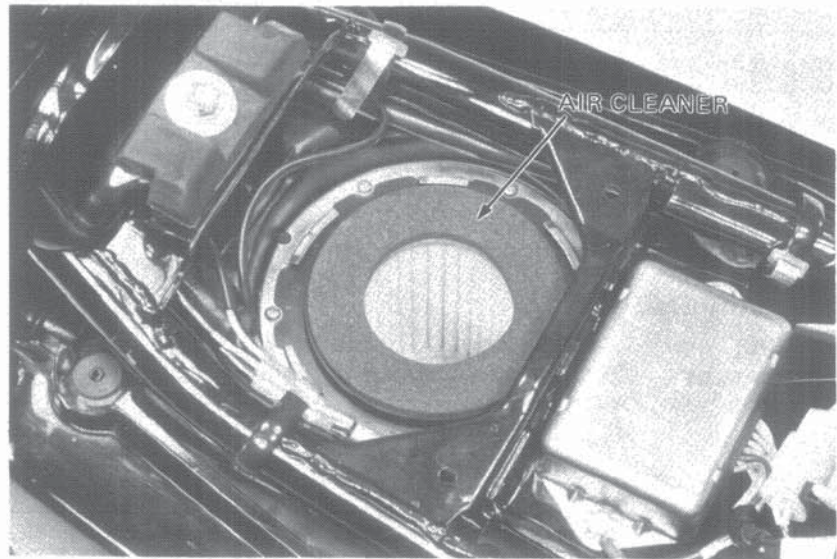

Clean the air cleaner element by tapping it lightly to loosen dust. Remove the remaining dust with compressed air.  
Replace if necessary.

### NOTE

Install the cover with the "TOP" mark facing the front.

Install element and cover. Install seat.

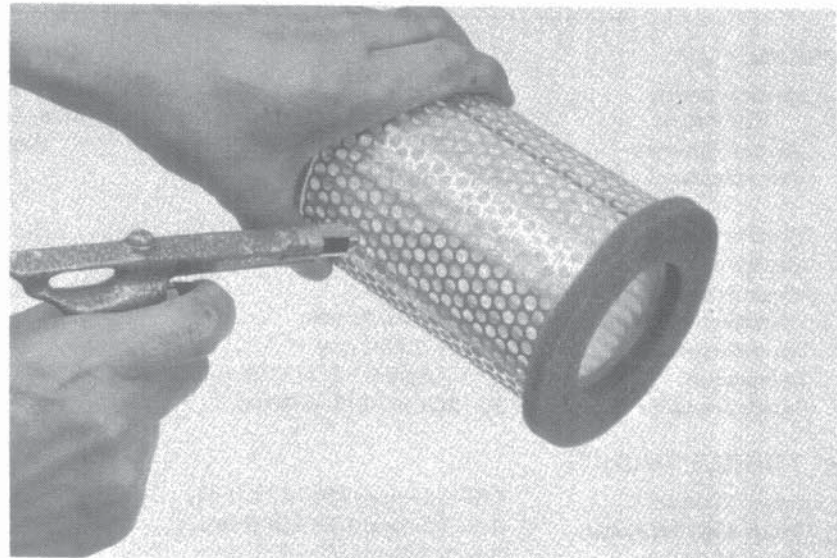





## CRANKCASE BREATHER

Remove the two drain plugs from the tubes, and drain deposits.  
Install the two drain plugs.

### NOTE

Service more frequently when driven in rain, or full at throttle openings, dropped or washed often. Service if the deposit level can be seen in the transparent section of the drain tubes.

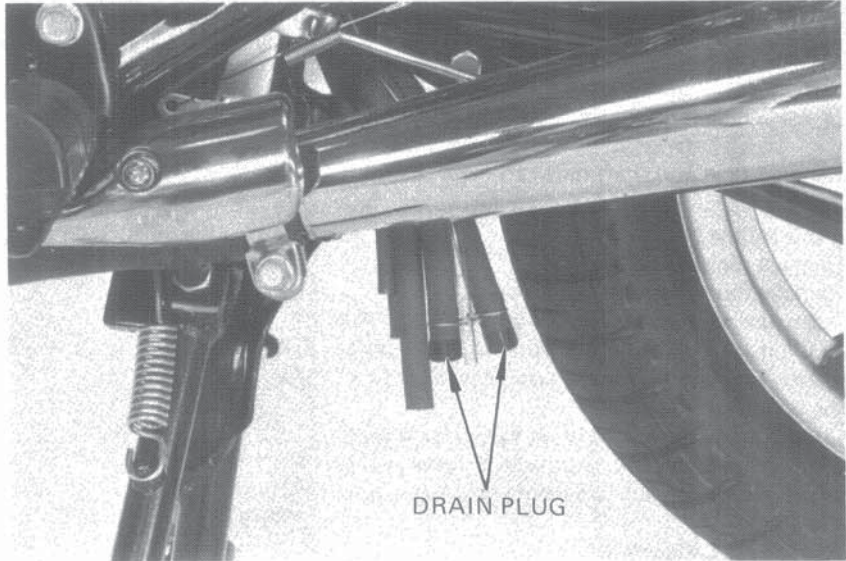

## FUEL LINE

Make sure that the fuel lines and connections are not deteriorated, damaged or leaking. Replace any parts which have deterioration, damage or leakage.

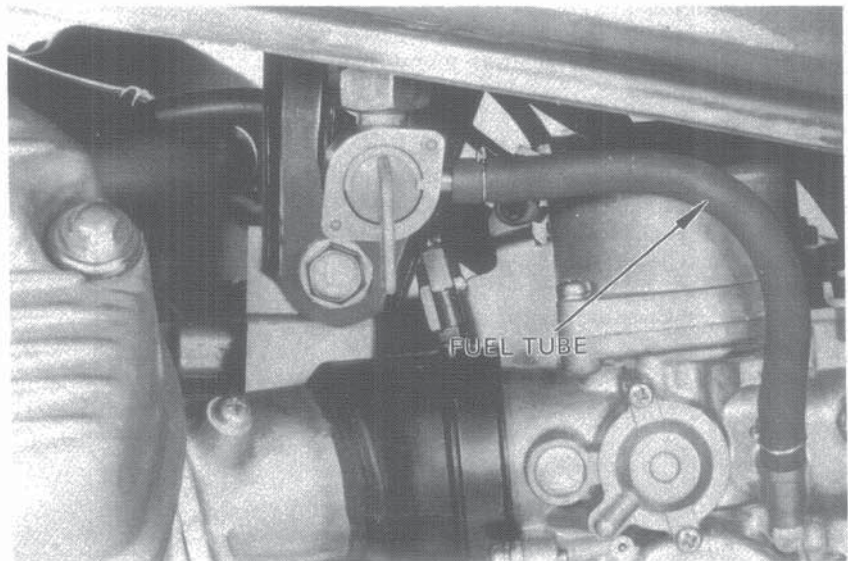

## SPARK PLUG

Disconnect the spark plug cap and remove the spark plug.

Visually inspect the spark plug electrodes for wear. The center electrode should have square edges and the side electrode should have a constant thickness. Discard the spark plug if there is apparent wear or if the insulator is cracked or chipped. If the spark plug deposits can be removed by sandblasting, the spark plug can be reused.

Adjust the spark plug gap by bending the side electrode.

**SPARK PLUG GAP:** 0.6-0.7 mm  
(0.024-0.028 in.)

### STANDARD SPARK PLUG:

USA model ND X24ES-U NGK D8EA

Canadian model ND X24ESR-U

NGK DR8ES-L

Check the sealing washer condition.

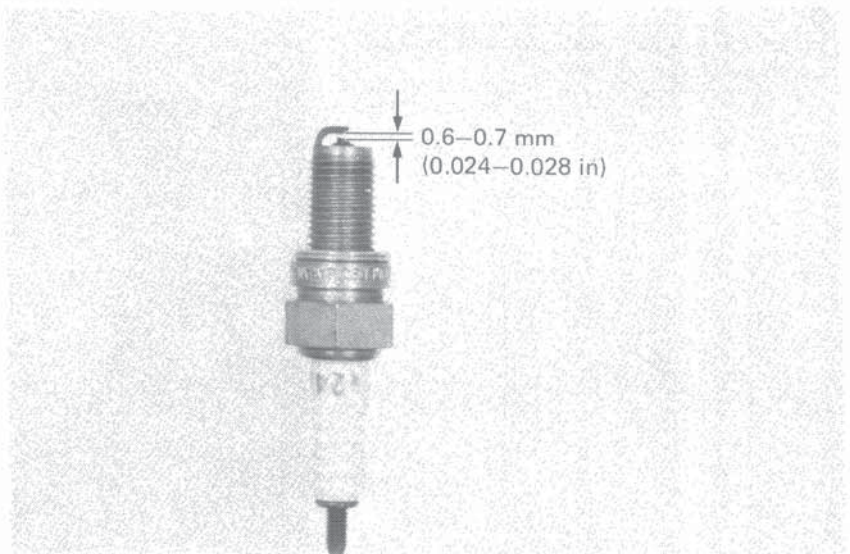





## VALVE CLEARANCE

### NOTE

This adjustment must be performed while the engine is cold (below 35°C).

Remove the crankshaft hole cap from the transmission cover and the timing inspection hole cap from the rear cover.

Remove the spark plug caps.

Remove the cylinder head covers.

Turn the crankshaft clockwise and align the "TL" mark on the rotor with the pulser index mark. The left cylinder must be at T.D.C. of the compression stroke.

Check the intake and exhaust valve clearance of the left cylinder by inserting a feeler gauge between the clearance adjusting screw and valve stem.

### VALVE CLEARANCE

IN: 0.08 mm (0.003 in.)

EX: 0.10 mm (0.004 in.)

Adjust, by loosening the lock nut, and turning the screw until there is a slight drag on the feeler gauge.

Hold the screw and tighten the lock nut.

Recheck the valve clearances. Turn the crankshaft clockwise and align the "TR" mark on the rotor with the pulser index mark. The right cylinder must be at the T.D.C. of the compression stroke.

Check the intake and exhaust valve clearance of the right cylinder as described for the left cylinder.

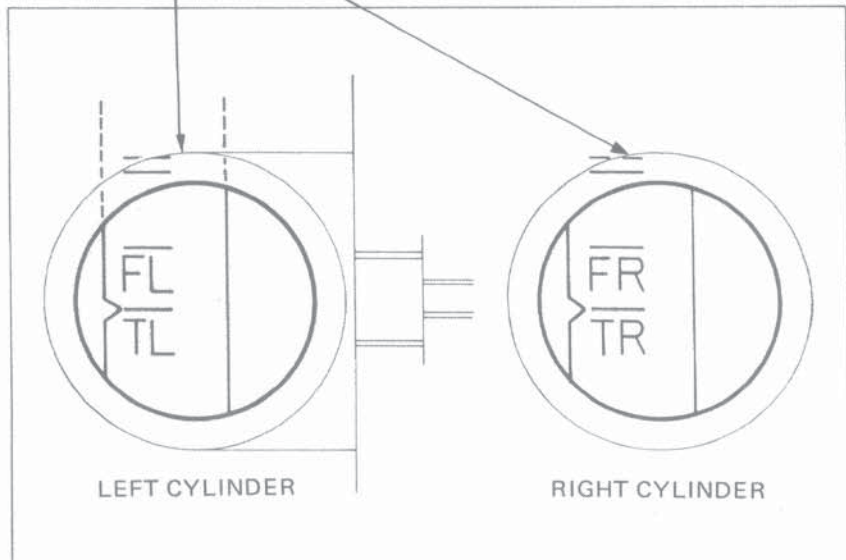
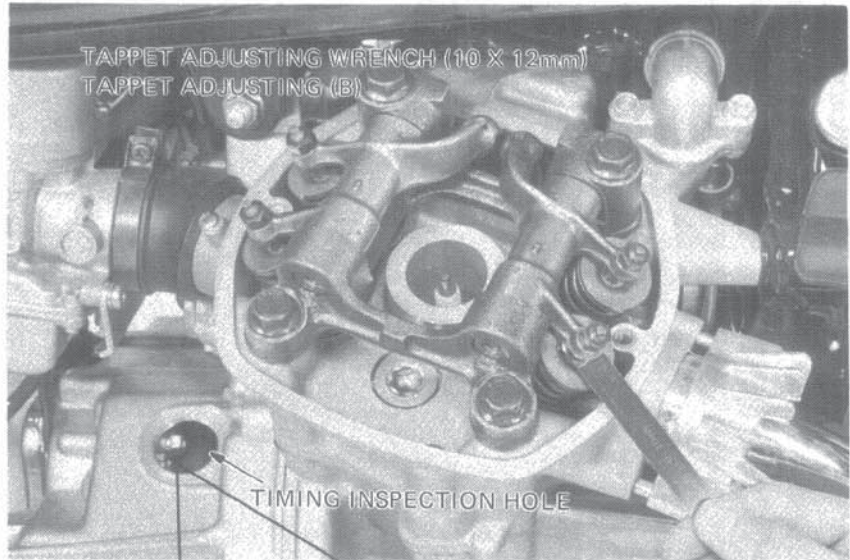

### NOTE

Coat the cylinder head cover bolt rubbers with oil before tightening.

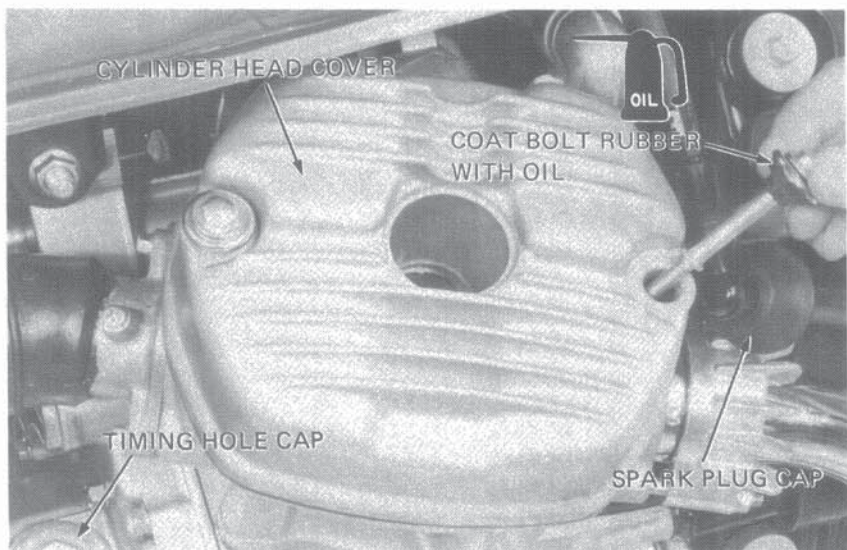





## CAM CHAIN

Remove the left cylinder head cover.  
Remove the crankshaft and timing hole caps from the transmission and rear covers respectively.

Slowly turn the crankshaft clockwise and align the rotor "TL" mark with the pulser index mark. Be sure the left piston is at TDC of the compression stroke.

Loosen the cam chain tensioner lock bolt. When this bolt is loosened, the cam chain tensioner will automatically position itself to provide the correct cam chain tension.

Retighten the lock bolt.

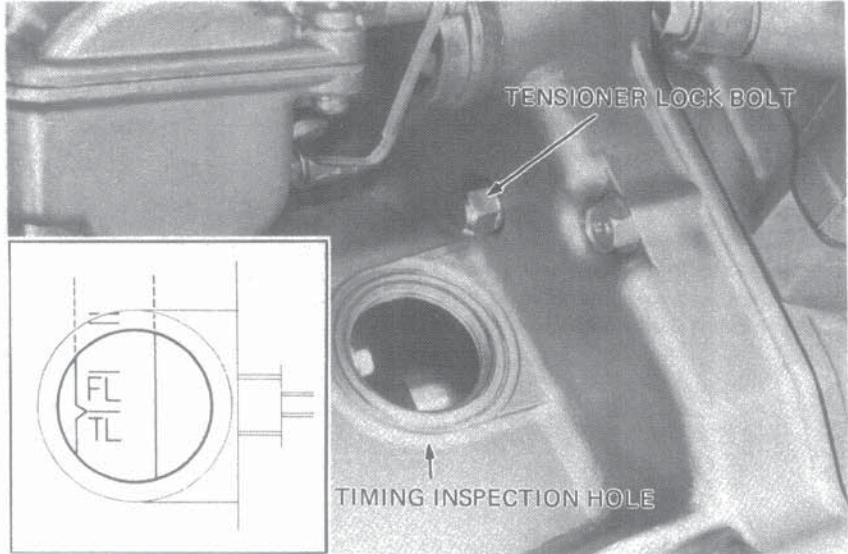

## THROTTLE OPERATION

Check that there is no deterioration, damage, or kinks in the throttle cables, and that the throttle grip free play is **2-6 mm (1/8-1/4 in.)** on the outer edge of the throttle grip flange.

Check for smooth throttle grip rotation from fully closed to fully open positions at all steering positions.

Check that the throttle grip automatically returns from fully open to fully closed position when released.

Adjust or replace, if necessary.

THROTTLE GRIP FREE PLAY:

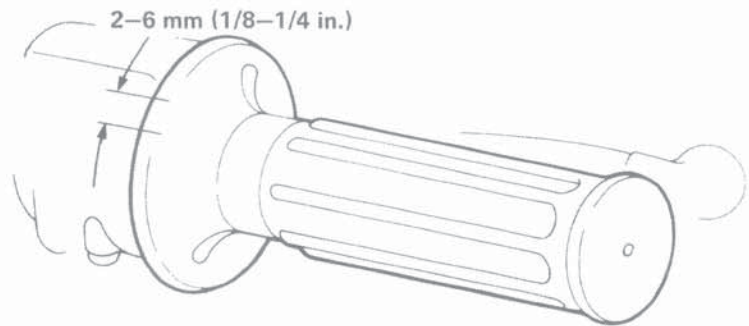

Throttle grip free play can be adjusted at either end of the throttle PULL cable. Major adjustments must be made at the lower adjuster. Adjust by loosening the adjuster lock nut and turning the adjuster. Tighten the locknut. Minor adjustments must be made at the upper adjuster.

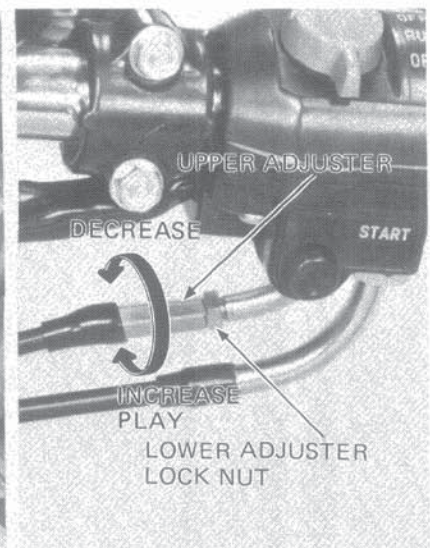
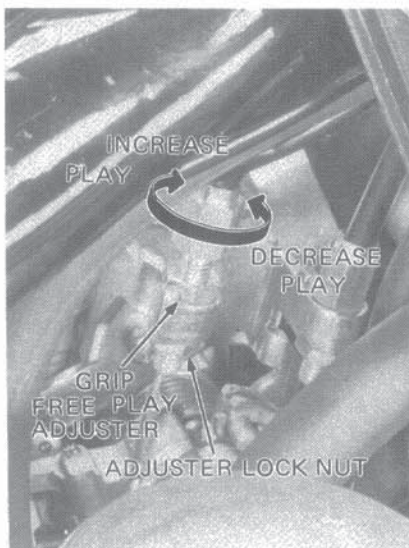





## IDLE SPEED

### NOTE

The engine must be warm for accurate idle adjustment. Ten minutes of stop and go driving is sufficient, or when the temperature gauge needle is in the wide white line.

Warm up the engine, place the transmission in neutral and the motorcycle on its center stand. Adjust idle speed with the throttle stop screw.

**IDLE SPEED: 1,100 ± 100 rpm**

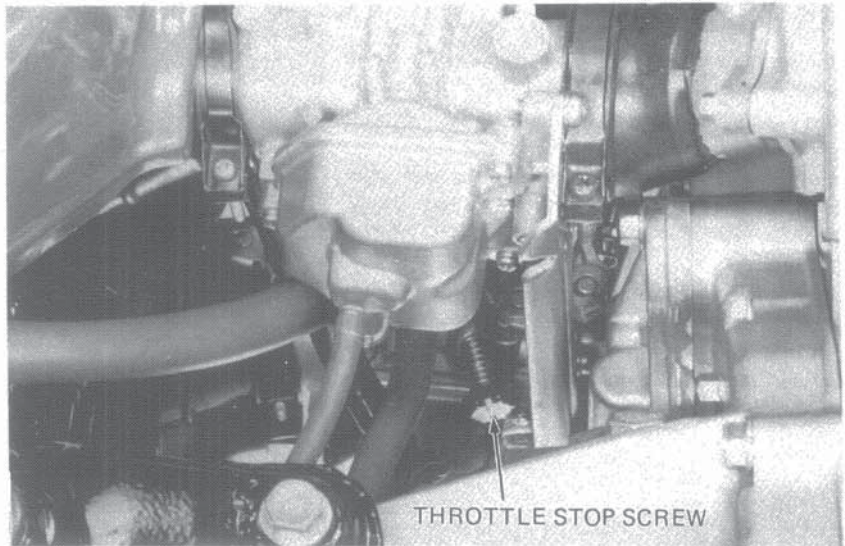

THROTTLE STOP SCREW

## CARBURETOR CHOKE

Operate the choke knob and check for smooth operation.

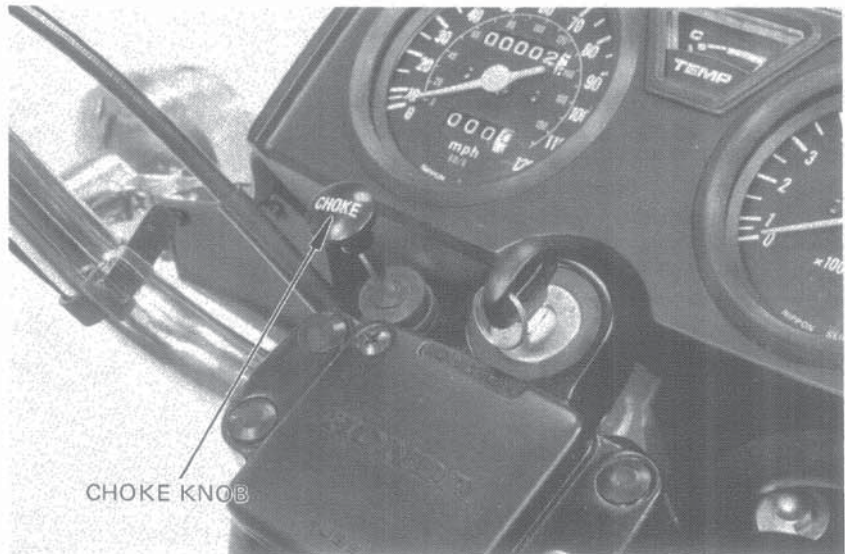

CHOKE KNOB





## CARBURETOR SYNCHRONIZATION

### NOTE

This adjustment is performed with engine at normal operating temperature, transmission in neutral, and vehicle on center stand.

Remove the plugs from the carburetor spacers and install adapters.  
Connect the vacuum gauges.

Start the engine and adjust the idle speed to  $1,100 \pm 100$  rpm.

The difference of vacuum between cylinders should be within **40 mm (1.6 in) Hg**.

MUST BE WITHIN 40mm (1.6 in) Hg OF EACH OTHER

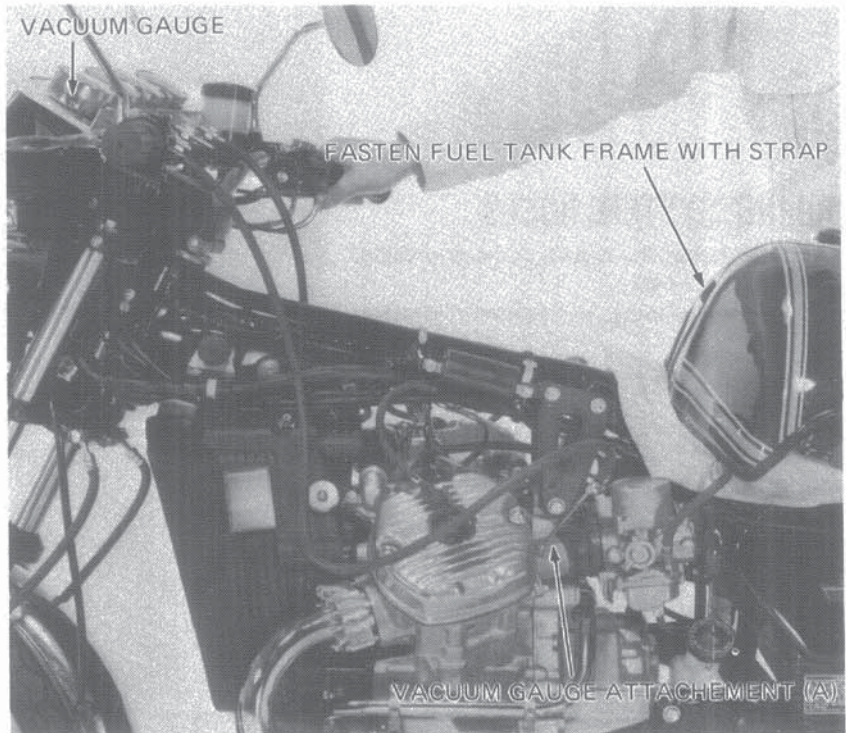
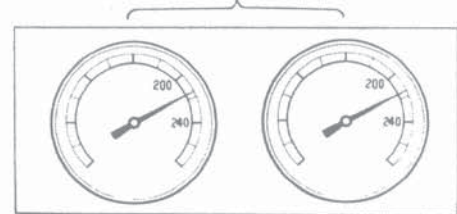

### • ADJUSTMENT

Prepare a longer fuel tube and connect it to the fuel tank and carburetor.  
Position the tank higher than normal.  
Loosen adjusting screw lock nut.  
Balance the vacuum between cylinders to within **40 mm (1.6 in) Hg** of each other, by turning the adjusting screw.  
Hold adjusting screw, and tighten the lock nut.  
Recheck the synchronization and idle speed.  
Reinstall the fuel tank and seat.

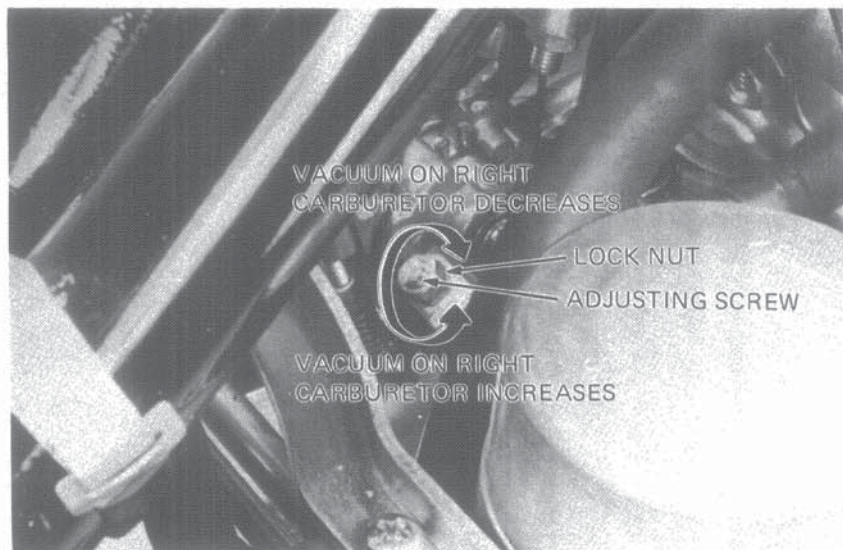





**INSPECTION AND ADJUSTMENT**

**COOLANT**

Check the coolant level of the reserve tank with the engine running at normal operating temperature.

The level should be between the "FULL" and "LOW" level lines.

If necessary, remove the reserve tank cap and fill to the "FULL" level line.

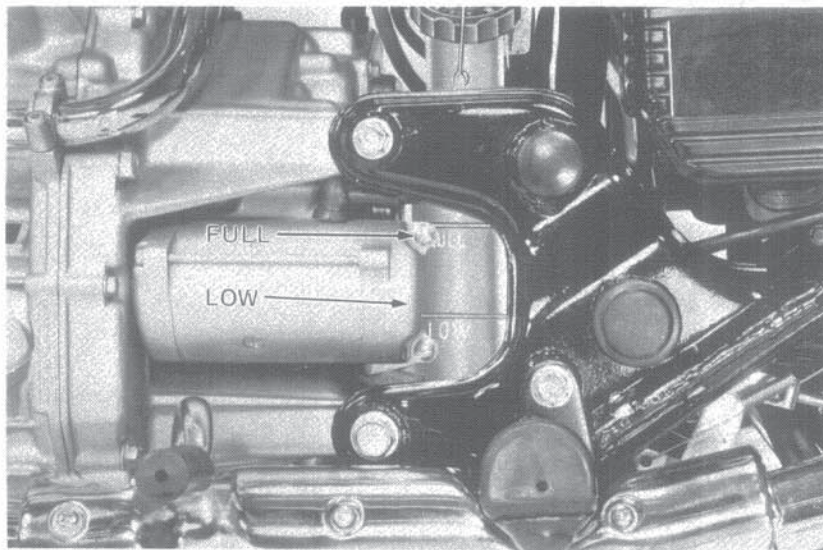

**COOLING SYSTEM HOSES**

Inspect the hoses for cracks or deterioration, and replace if necessary.

Check the hose clamps, and tighten if necessary.

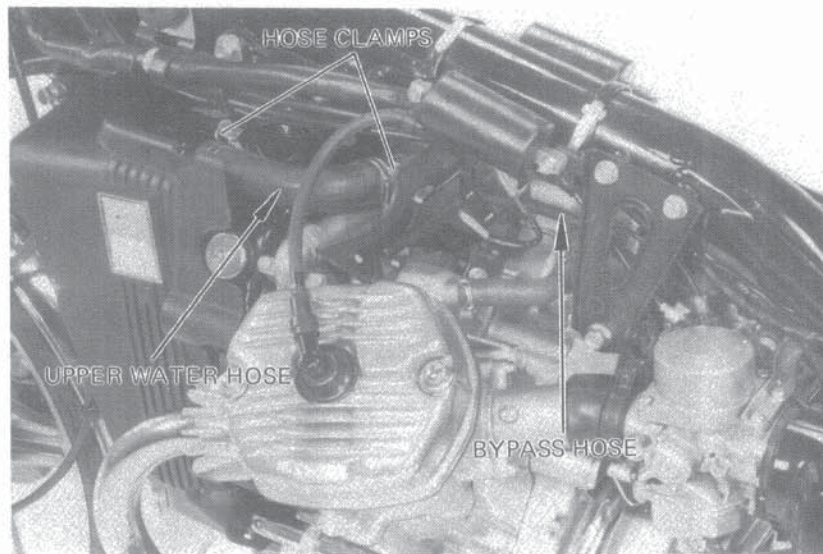

**RADIATOR CORE**

Check the air passages for clogging or damage. Straighten bent fins.

Remove insects, mud or any obstruction with compressed air or low water pressure.

Replace the radiator if the air flow is restricted over more than 20% of the radiating surface.

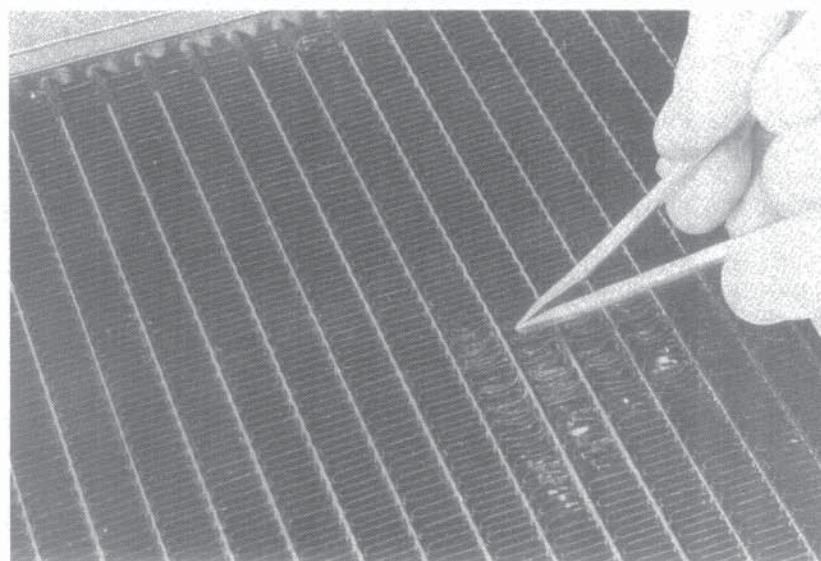





## BATTERY

Remove the left side cover.  
Inspect the battery electrolyte level.  
When the electrolyte level nears the lower level mark, fill with distilled water to the upper level mark.  
If sulfation forms on the battery walls or sediments (paste) accumulate on the bottom of the battery, replace the battery.

### NOTE

Add only distilled water. Tap water will shorten the service life of the battery.  
Never add more electrolyte.

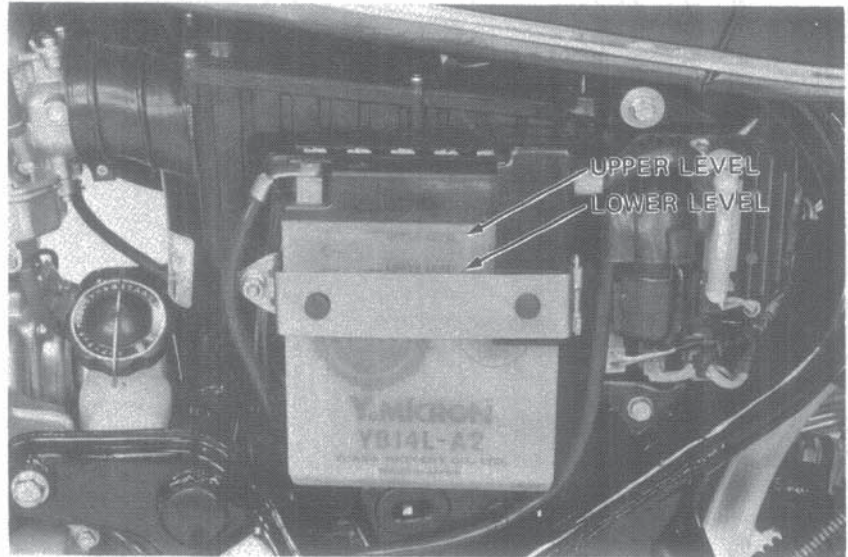

## BRAKE FLUID LEVEL

Check that the brake fluid reservoir is filled to the level mark engraved inside the reservoir.  
If the level is lower than the mark, fill the reservoir with DOT-3 BRAKE FLUID up to the level mark.  
Check the entire system for leaks, if the level is low.

### CAUTION

- Do not mix different brands of fluid, as they are not compatible.
- Do not remove the cap until the handlebar has been turned full left so that the reservoir is level.
- Avoid operating the brake lever with the cap removed. Brake fluid will flow out if the lever is pulled.

### WARNING

The battery electrolyte contains sulfuric acid. Protect your eyes, skin and clothing. In case of contact, flush thoroughly with water and call a doctor if your eyes were exposed.







## BRAKE FLUID REPLACEMENT

Check the fluid level with the fluid reservoir parallel with the ground.

### CAUTION

*Be sure to install the diaphragm on the reservoir when operating the brake lever. Failure to do so will force the fluid out of the reservoir by the system pressure pumped up by the operation of the brake lever.*

*Avoid spilling fluid on painted surfaces. Place a rag over the fuel tank whenever the system is serviced.*

### • BRAKE FLUID DRAINING

Remove the bleeder valve dust cap. Connect a bleed hose and place one end in a clean container.

Loosen the caliper bleeder valve and pump up the system pressure by operating the brake lever/pedal.

Stop operating the lever/pedal when no fluid is flowing out of the bleeder valve.

### • BRAKE FLUID FILLING

### CAUTION

*Check the fluid level often while bleeding the brake, to prevent air from being pumped into the system. Do not mix different brands of fluid since they are not compatible.*

Close the bleeder valve, fill the reservoir, and install the diaphragm.

To prevent piston overtravel and brake fluid seepage, keep a 20 mm space between the lever and the handlebar grip when bleeding the front brake system.

Pump up the system pressure with the lever until there are no air bubbles in the fluid flowing out of the reservoir small hole (until lever resistance is felt).

### • AIR BLEEDING

Pull the brake lever all the way back to the handlebar grip. Screw out the bleeder valve about 1/2 turn, and retighten.

### NOTE

Do not release the lever until the bleeder valve has been closed.

Release the lever gradually and wait for several seconds after it reaches the end of its travel.

Repeat the above steps until there are no air bubbles in the fluid flowing out of the bleeder valve.

Fill the reservoir up to the UPPER FLUID LEVEL.

Check the entire system for leaks by operating the lever.

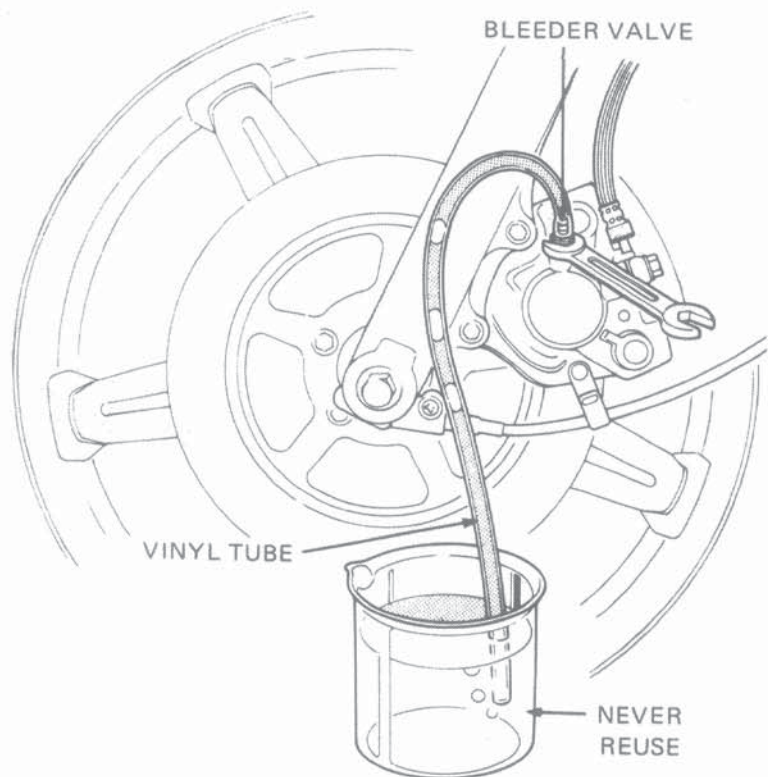
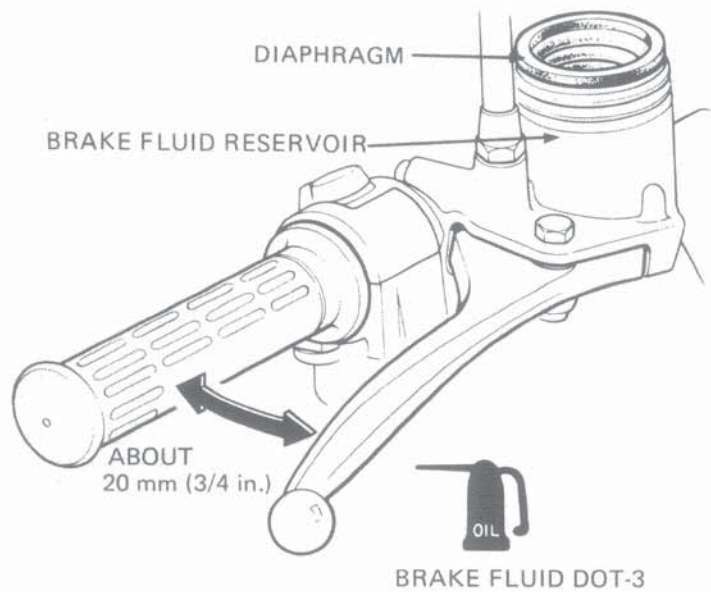

### WARNING

*A contaminated brake disc or pads reduces stopping power. Replace contaminated pads, and clean a contaminated disc with a good quality degreasing agent.*





## BRAKE SYSTEM

### • BRAKE PAD WEAR

Remove the cap from the caliper and check for brake pad wear.

Replace the brake pads if the red line on the top of the pads reaches the edge of the brake disc (Section 15).

**CAUTION**

*Always replace the brake pads in pairs to assure even disc pressure.*

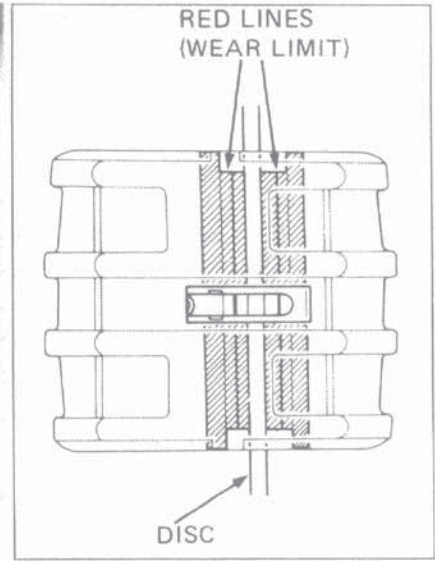
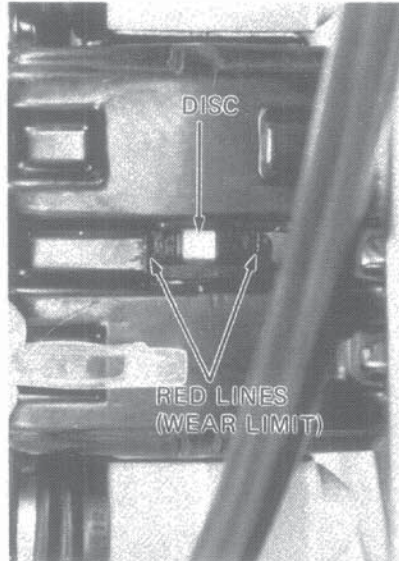

### • BRAKE SHOE INSPECTION (WEAR INDICATOR)

Replace the brake shoes if the arrow on the brake arm aligns with the reference mark "△" on full application of the rear brake.

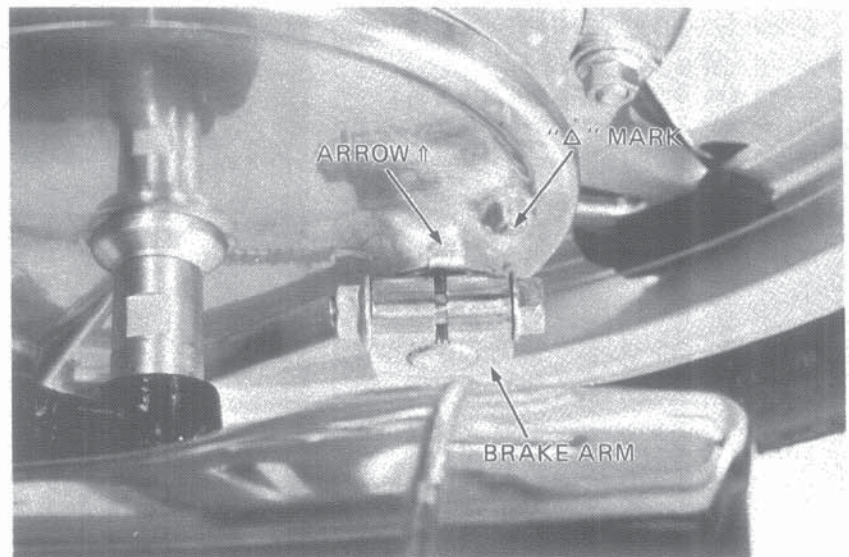

### • BRAKE SYSTEM HOSE

Make sure that the brake hose is not deteriorated and check the entire brake system for leaks.

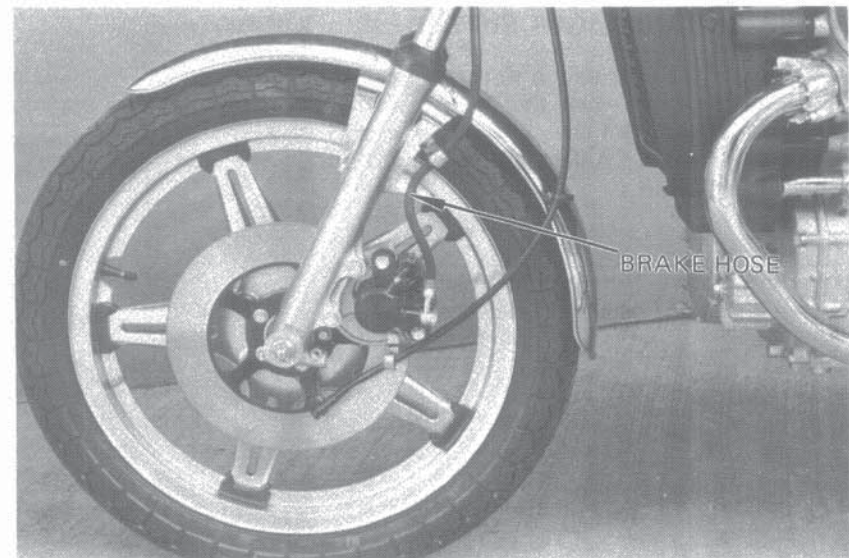





**INSPECTION AND ADJUSTMENT**

• **BRAKE PEDAL HEIGHT**

Loosen the lock nut.  
Adjust the brake pedal height by turning the stopper bolt.  
Retighten the lock nut.

**NOTE**

After adjusting the brake pedal height, check the rear brake light switch and adjust if necessary.

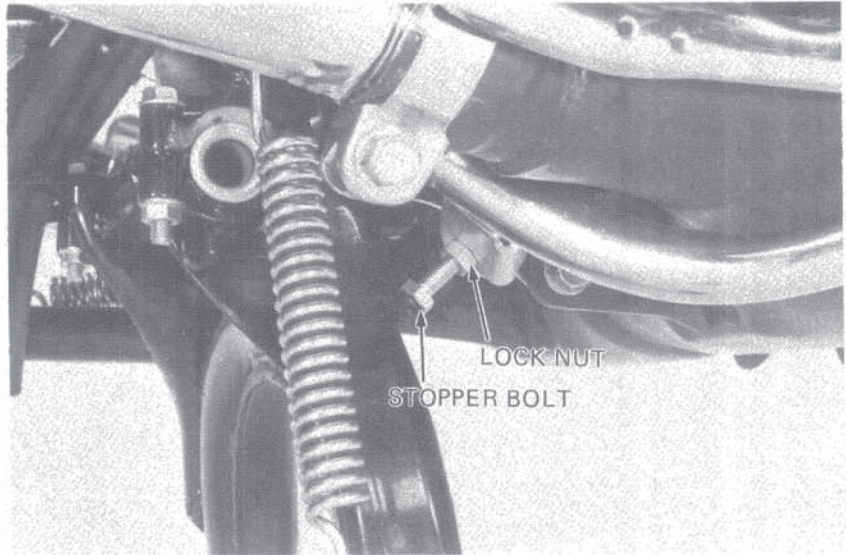

• **BRAKE PEDAL FREE PLAY**

Check the brake pedal free play.  
**FREE PLAY: 20–30 mm (3/4–1-1/4 in.)**  
If adjustment is necessary, turn the rear brake adjusting nut.

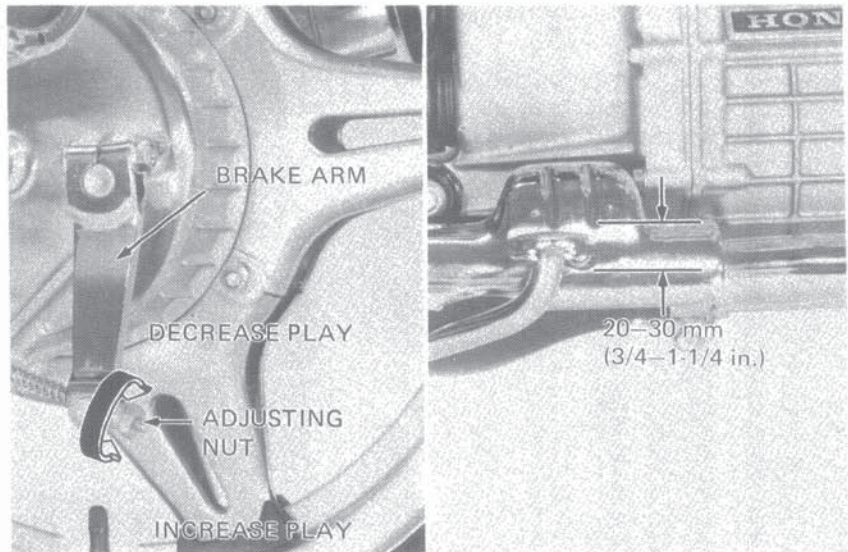

• **REAR BRAKE LIGHT SWITCH**

Adjust the brake light switch so that the brake light will come on when the brake pedal is depressed **20 mm (3/4 in)**, when the brake begins engagement. Adjust by turning the switch adjusting nut.

**NOTE**

Perform brake light switch adjustment after adjusting brake pedal play and pedal height.

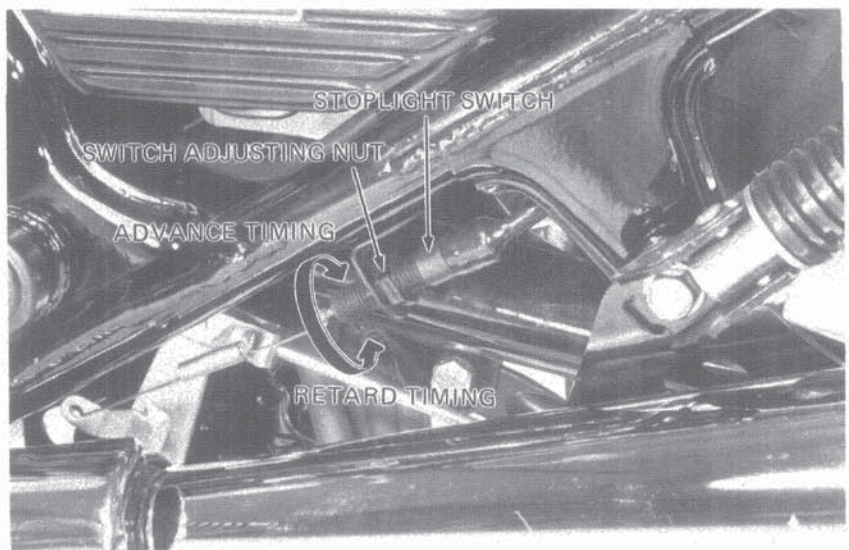





### HEADLIGHT AIM

The headlight beam can be adjusted vertically and horizontally.

Adjust vertically by turning the vertical adjustment screw shown.

Adjust horizontally by turning the horizontal adjustment screw shown.

**CAUTION**

*Adjust the headlight beam as specified by local laws and regulations.*

**WARNING**

*An improperly adjusted headlight may blind oncoming drivers, or it may fail to light the road for a safe distance.*

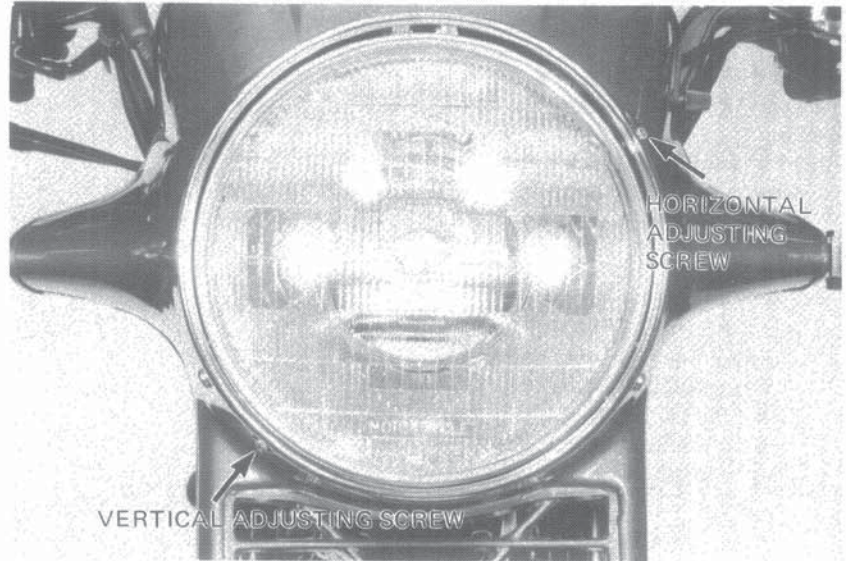

### CLUTCH FREE PLAY

Measure the clutch lever free play.

**CLUTCH LEVER FREE PLAY: 10-20 mm (3/8-3/4 in.)**

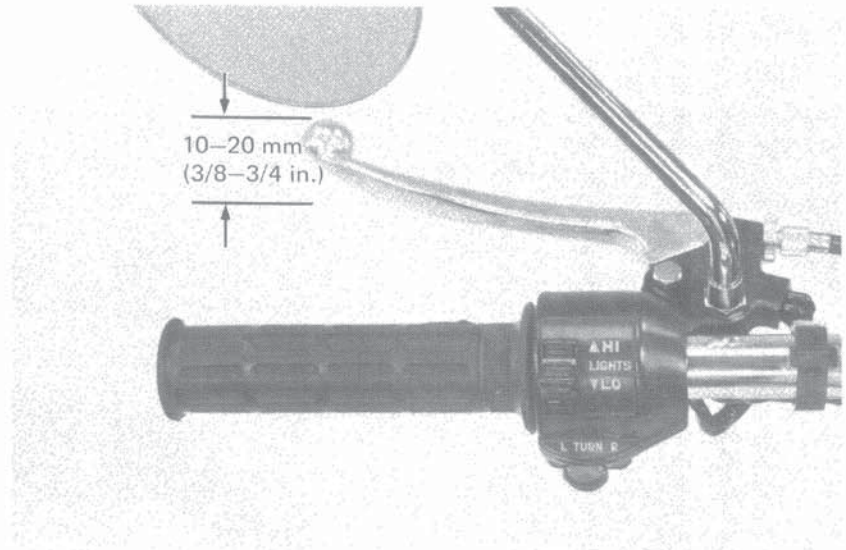

Major adjustments should be made using the adjuster located at the clutch housing. Loosen the lock nut and turn the clutch cable adjusting nut.

Minor adjustments can be made with the clutch cable adjuster located on the clutch lever. Loosen the lock nut and turn the adjuster.

**NOTE**

Do not allow the threads at the adjuster to come out by more than 8 mm (0.3 in.).

**WARNING**

*Do not burn yourself on the exhaust pipe.*

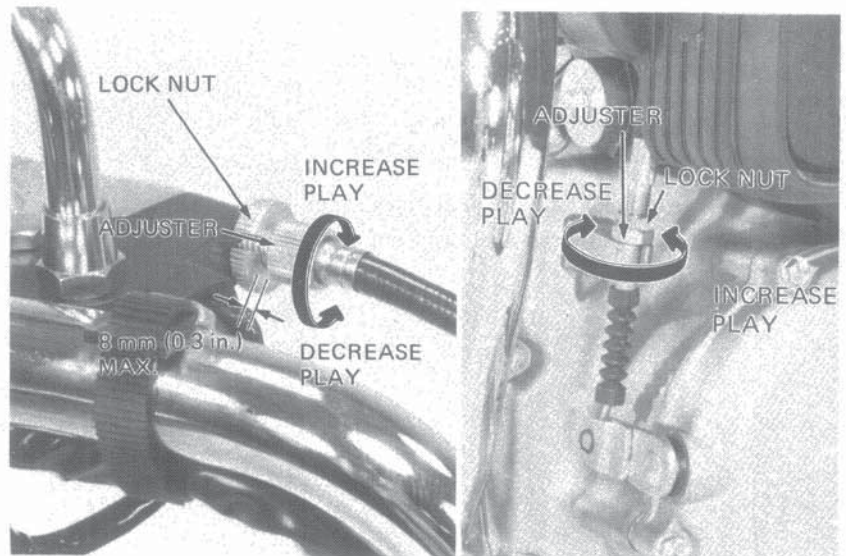

Recheck the clutch operation.





**INSPECTION AND ADJUSTMENT**

**SIDE STAND**

Check the rubber pad for deterioration or wear. Replace if any wear extends to wear line as shown.

Check the side stand spring for damage and loss of tension, and the side stand assembly for freedom of movement and bend.

**NOTE**

- When replacing, use a rubber pad with the mark "Over 260 lbs ONLY".
- Spring tension is correct if the measurements fall within **2-3 kg (4.4-6.6 lb)**.  
When pulling the side stand lower end with a spring scale.

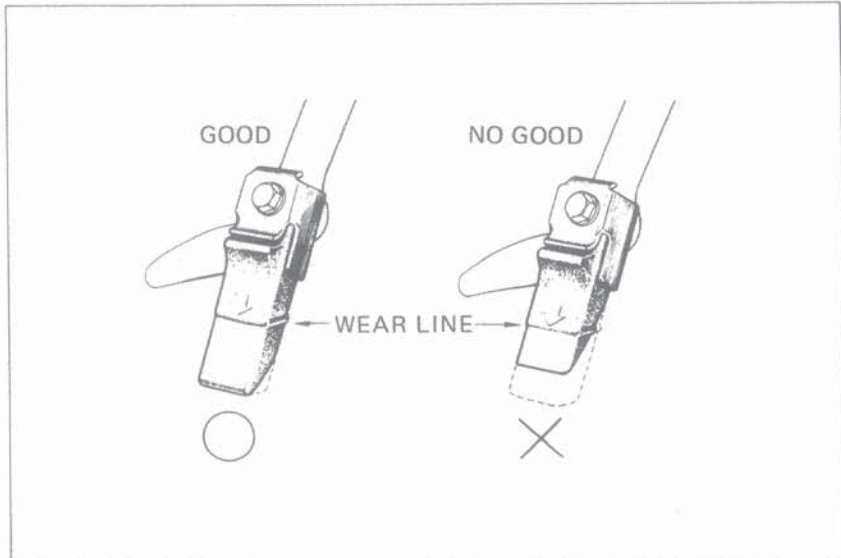

**SUSPENSION**

• **FRONT**

Check the action of the front forks by compressing them several times.

Check the entire fork assembly for signs of leaks or damage.

Replace any components which are unrepairable.

Torque all nuts and bolts.

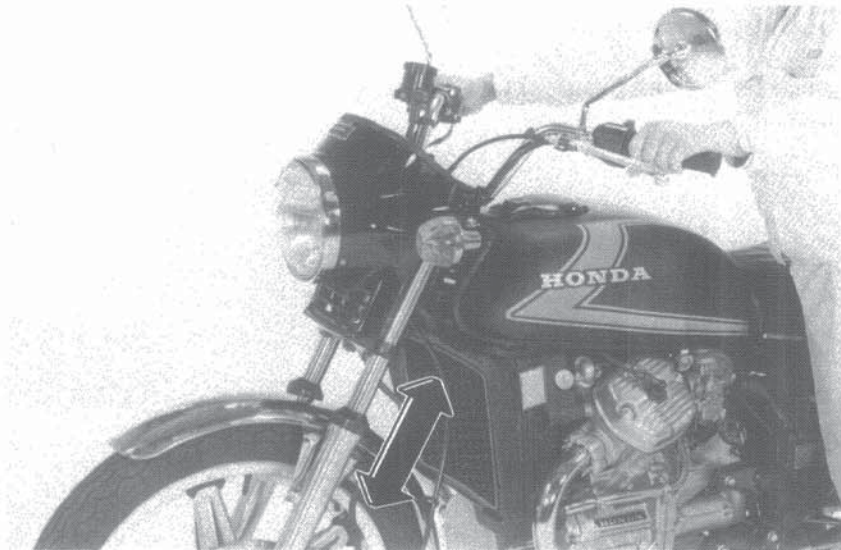

• **REAR**

Place the motorcycle on a support to raise the rear wheel.

Move the rear wheel sideways with force to see if the swing arm bushings are worn. Replace if excessively worn.

Inspect the entire suspension assembly to be sure it is securely mounted and not damaged or distorted.

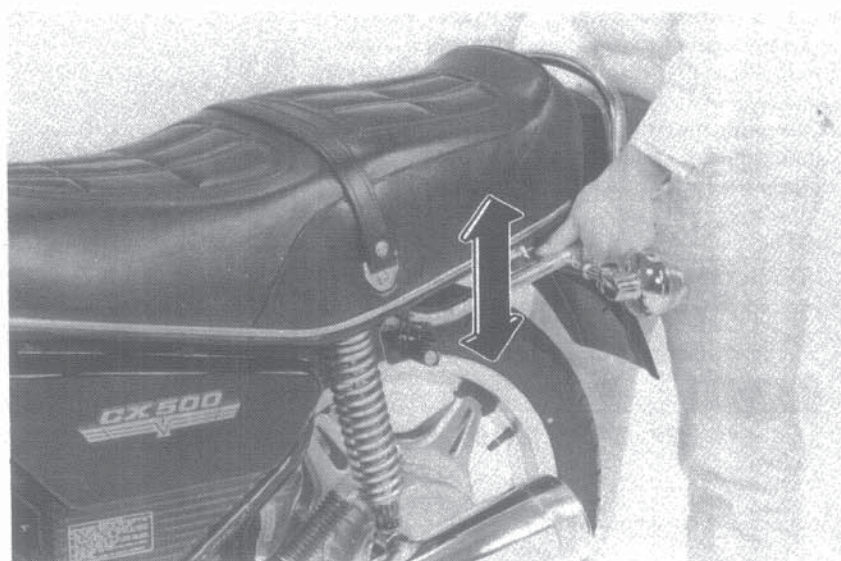





### WHEELS

#### • TIRE PRESSURE

##### NOTE

Tire pressure should be checked when the tires are COLD.

Check the tires for cuts, imbedded nails or other sharp objects.

Cold tire pressures kg/cm <sup>2</sup> (psi)	Up to 90 kg (200 lb) load	Front: 1.75 (25) Rear : 2.0 (28)
	Up to vehicle Capacity load	Front: 1.75 (25) Rear : 2.5 (36)
Vehicle capacity load limit	150 kg (330 lbs)	
Tire size	Front: 3.25S19-4PR Rear : 3.75S18-4PR	
Tire brand	Front: YOKOHAMA Y-992 BRIDGESTONE S703 TUBELESS ONLY Rear : YOKOHAMA Y-987 BRIDGESTONE S21-R2 TUBELESS ONLY	

Check the front and rear wheels for trueness. (Section 13, 14)

### STEERING HEAD BEARING

##### NOTE

Check that the control cables do not interfere with the rotation of the handlebars.

Raise the front wheel off the ground.  
Check that the handlebar rotates freely.  
If the handlebar moves unevenly, binds, or has vertical movement, adjustment is necessary.  
Adjust the steering head bearing by turning the steering head adjusting nut with a pin spanner.

### NUTS, BOLTS, FASTENERS

Check that all chassis nuts, bolts and fasteners are tightened to their correct torque values.  
See page 1-4.

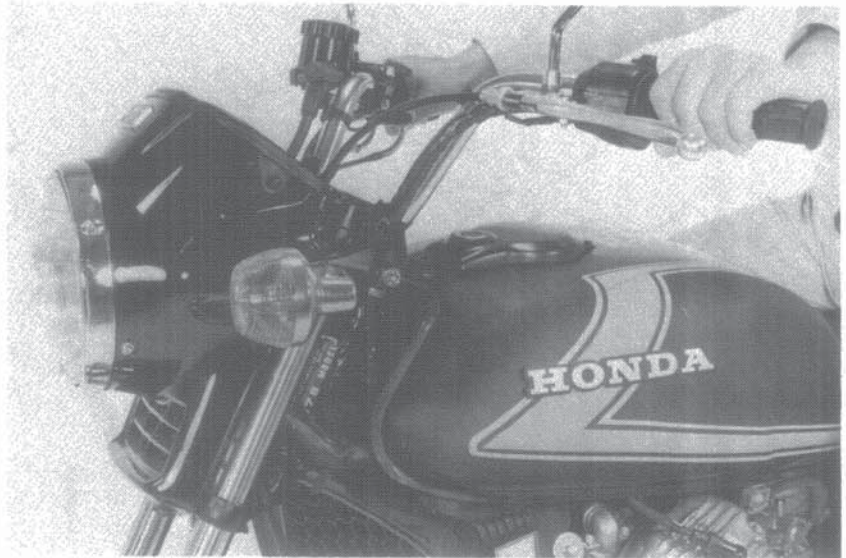
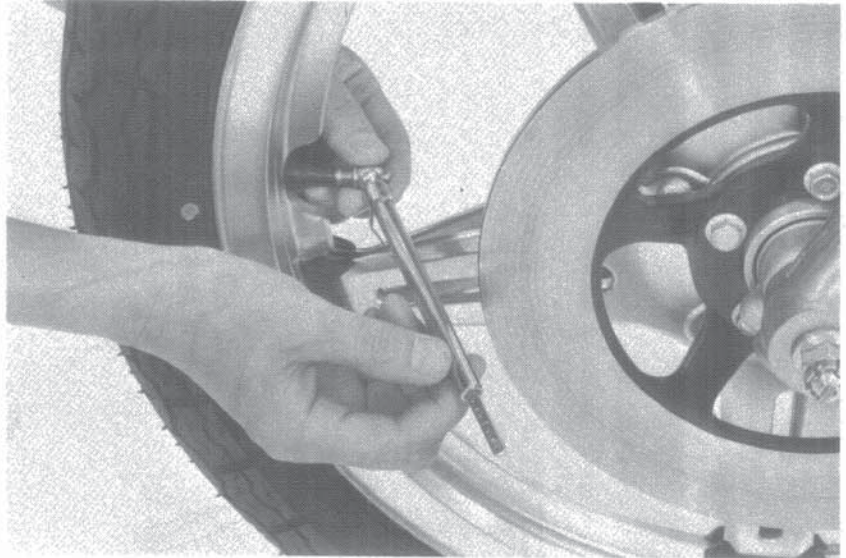



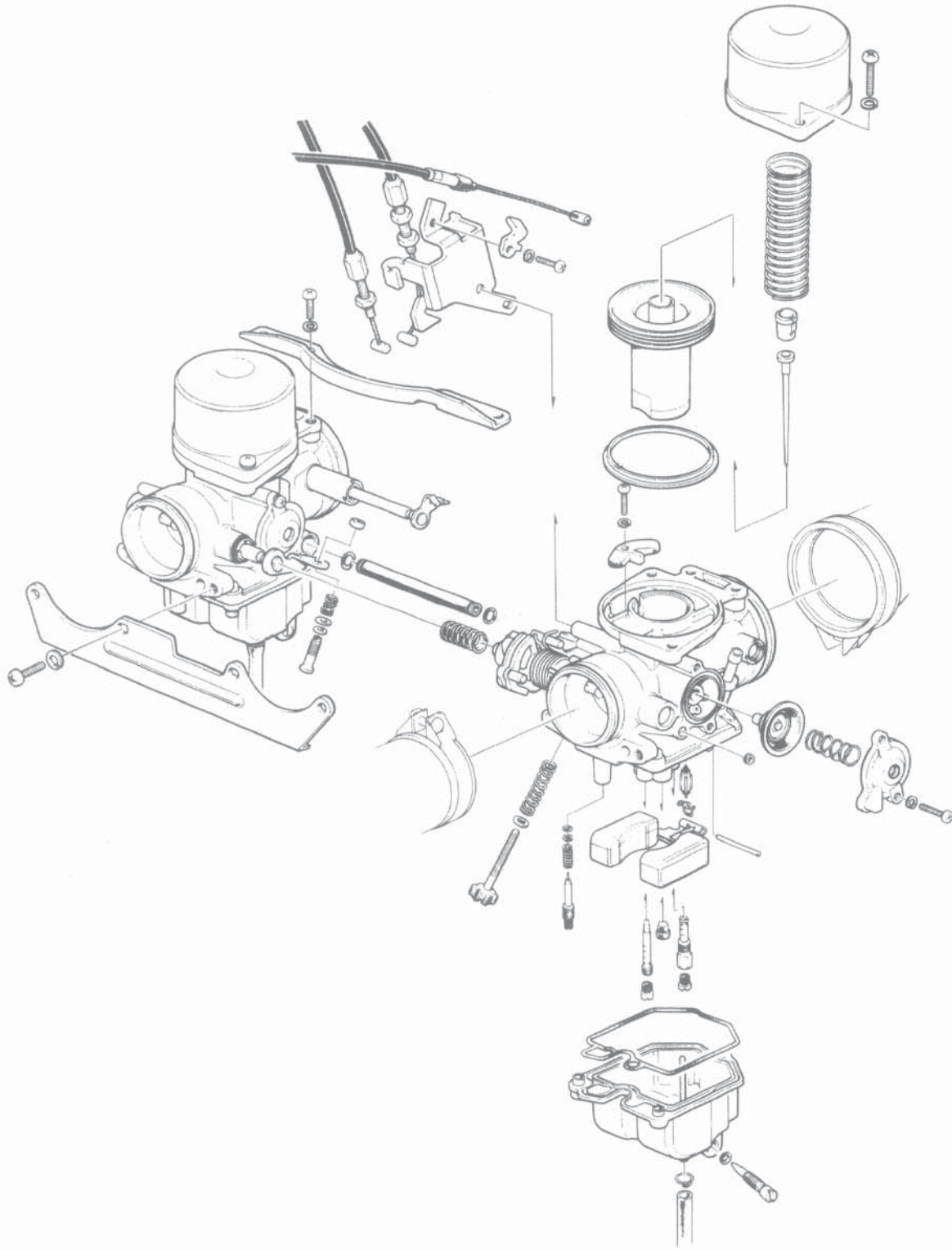



SERVICE INFORMATION	4-1	COMPONENT ASSEMBLY	4-8
TROUBLESHOOTING	4-1	FLOAT LEVEL ADJUSTMENT	4-9
CARBURETOR REMOVAL	4-2	FAST IDLE ADJUSTMENT	4-9
CARBURETOR SEPARATION	4-3	CARBURETOR INSTALLATION	4-9
CARBURETOR ASSEMBLY	4-4	PILOT SCREW INITIAL SETTING	4-10
VACUUM CYLINDER DISASSEMBLY/INSPECTION	4-5	FUEL TANK	4-11
FLOAT CHAMBER DISASSEMBLY	4-6	AIR CLEANER CASE	4-11
AIR CUTOFF VALVE DISASSEMBLY	4-8	CRANKCASE BREATHER SYSTEM	4-12

## SERVICE INFORMATION

### • WORKING PRACTICE

Use caution when working with gasoline. Always work in a well-ventilated area and away from sparks or open flames. When disassembling fuel system parts, note the locations of the O-rings. Replace them with new ones on reassembly.

The float bowls have drain plugs that can be loosened to drain residual gasoline.

### • SPECIAL TOOL

FLOAT GAUGE 07401-0010000

### • SPECIFICATIONS

ITEM	STANDARD
Venturi diameter	35 mm (1.38 in.)
Setting mark	VB26A
Float level	15.5 mm (0.61 in.)
Pilot screw	See Page 4-10
Idle speed	1,100 ± 100 rpm
Vacuum pressure difference between carburetors	40 mm Hg
Throttle grip free play	2 - 6 mm (1/8-1/4 in.)

## TROUBLESHOOTING

### Engine Cranks But Won't Start

1. No fuel in tank
2. No fuel getting to cylinders
3. Too much fuel getting to cylinders
4. No spark at plugs - ignition malfunction
5. Air cleaner clogged

### Engine Idles Roughly, Stalls, or Runs Poorly

1. Idle speed incorrect
2. Ignition malfunction
3. Low compression
4. Rich mixture
5. Lean Mixture
6. Air cleaner clogged
7. Air leaking into manifold

8. Fuel contaminated
9. Carburetors not synchronized
10. Faulty vacuum piston

### Lean Mixture:

1. Carburetor fuel jets clogged
2. Vacuum piston stuck closed
3. Fuel cap vent blocked
4. Fuel filter clogged
5. Fuel line blocked
6. Float valve faulty
7. Float level too low

### Rich Mixture:

1. Choke stuck closed
2. Float level set too high or float sticking
3. Carburetor air jets clogged
4. Sticking float
5. Dirty air cleaner





**FUEL SYSTEM**

**CARBURETOR REMOVAL**

- Turn the fuel valve off.
- Remove the seat and fuel tank.
- Remove the wire band, breather hose, bypass hose, and choke wire clamp.
- Remove the carburetor band.
- Remove the carburetor insulator.

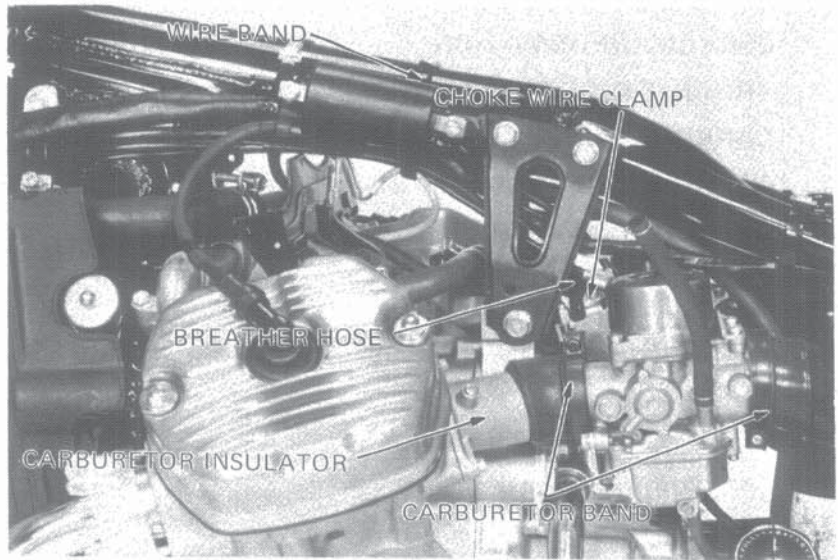

Remove both carburetors from the air cleaner tube by pushing them down and forward.

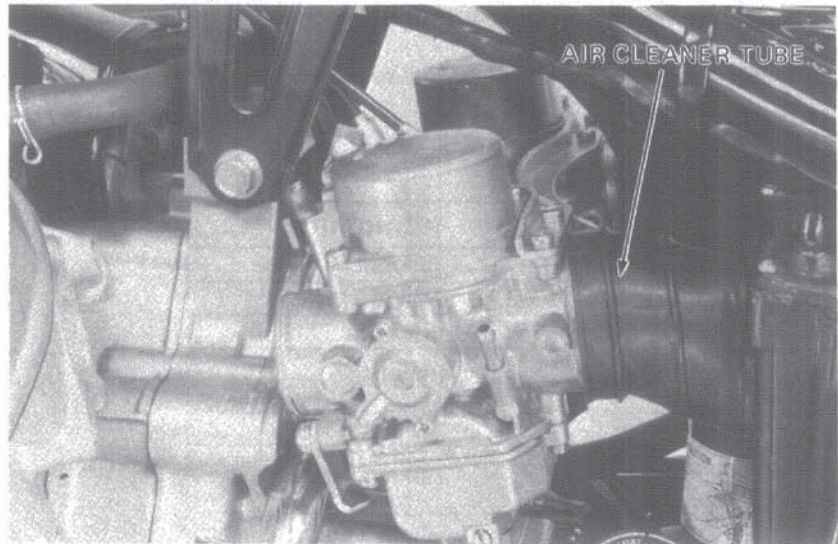

- Pull the carburetors towards the left.
- Loosen the lock nuts and disconnect the throttle cables.
- Disconnect the choke cable at the carburetors.
- Remove the carburetors.

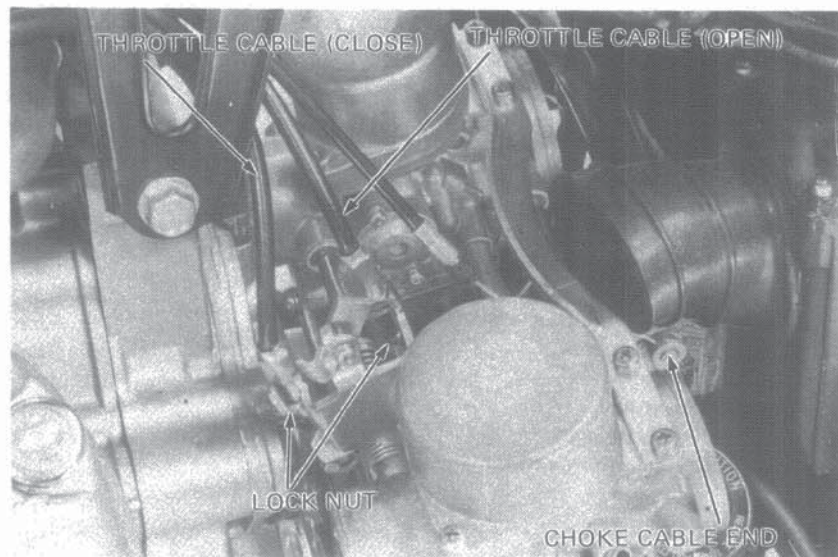





## CARBURETOR SEPARATION

**CAUTION**

*The carburetor is pre-set at the factory and pilot screw adjustment is not necessary except after overhauling it.*

Remove the synchronization adjustment screw.

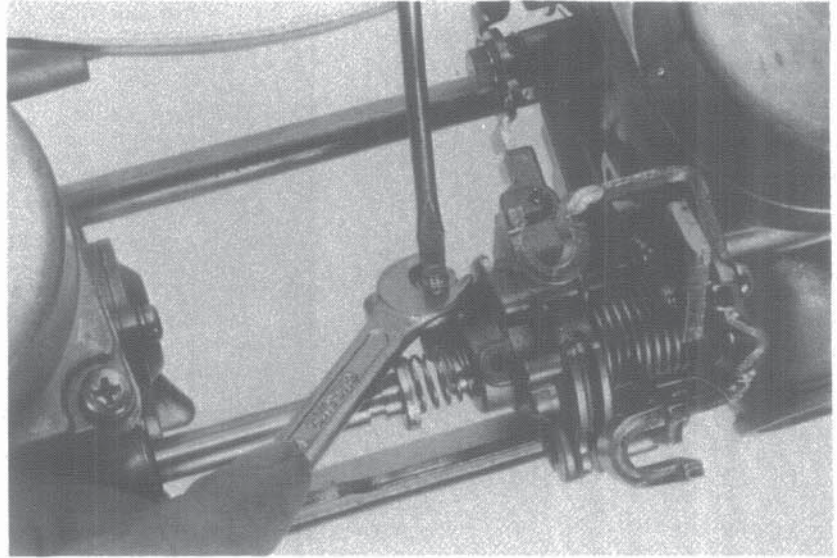

Remove the choke relief spring.

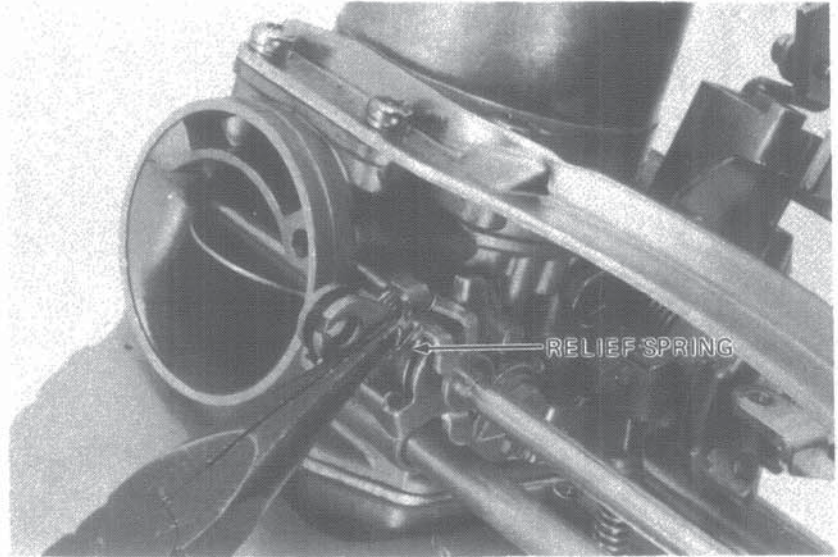

Remove the rear stay.

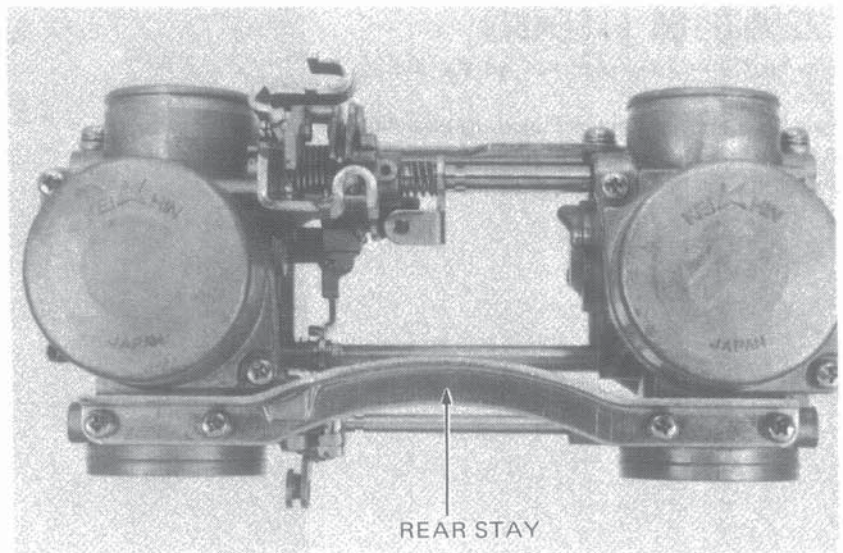





**FUEL SYSTEM**

Remove the front stay plate.

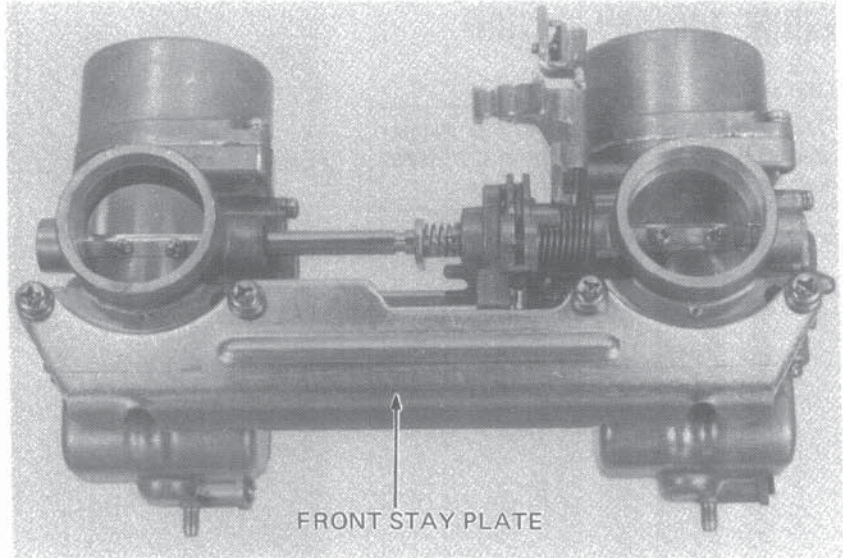

Separate the carburetors.

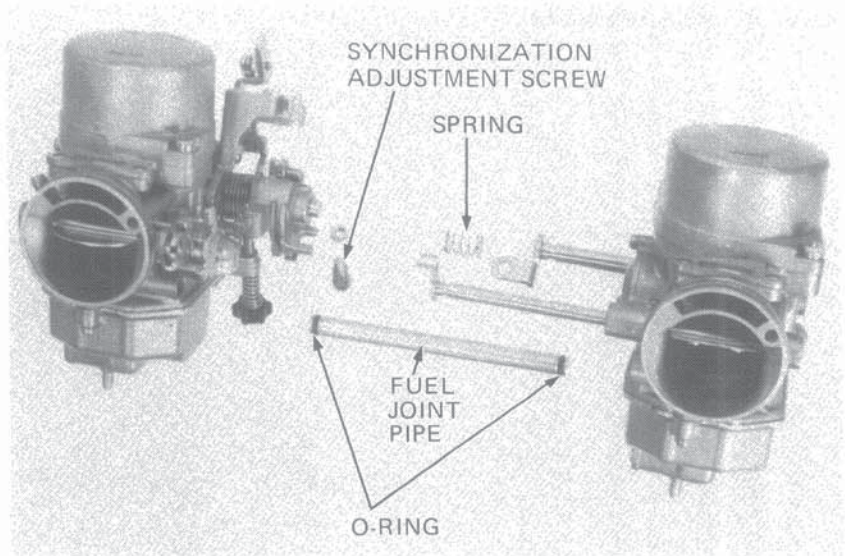

**CARBURETOR ASSEMBLY**

Slip an O-ring over each end of the fuel joint pipe.

Assemble the right and left carburetors making sure the spring are properly positioned.

Install the synchronization adjustment screw.

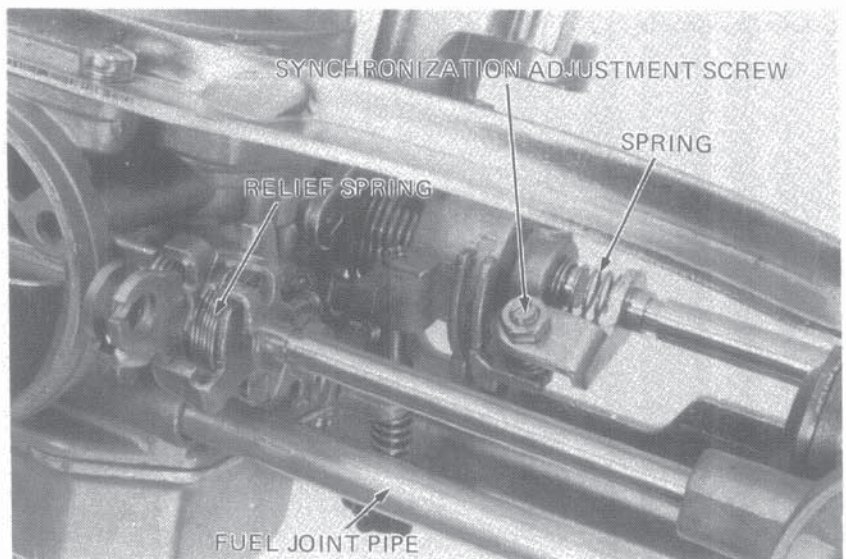





### VACUUM CYLINDER DISASSEMBLY/INSPECTION

Remove the vacuum cylinder from the carburetor.  
Remove the vacuum piston and inspect for wear, nicks, or scratches.  
Make sure the piston moves freely in the cylinder and in the bore of the carburetor.

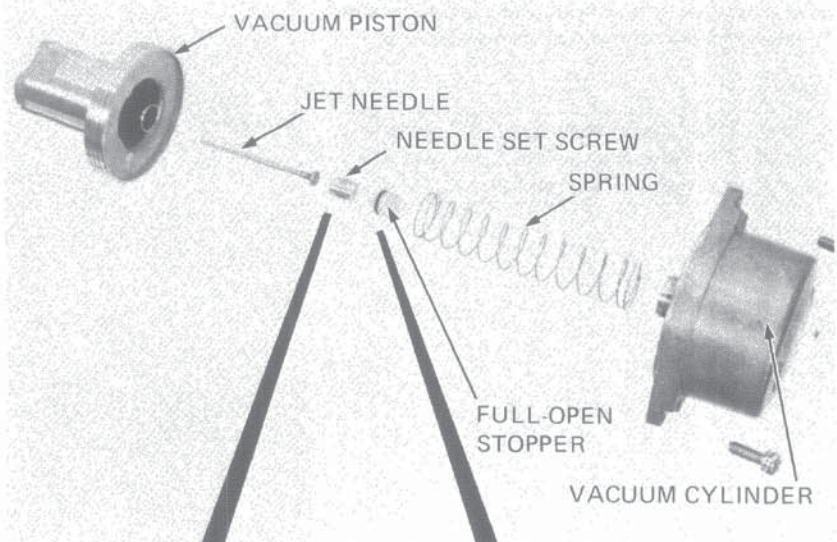

Remove the full open stopper.  
Remove the needle set screw and the jet needle.

**NOTE**

Inspect the needle and seat for deposits, grooves, or other damage.  
Carefully lift the seal ring off the carburetor body.

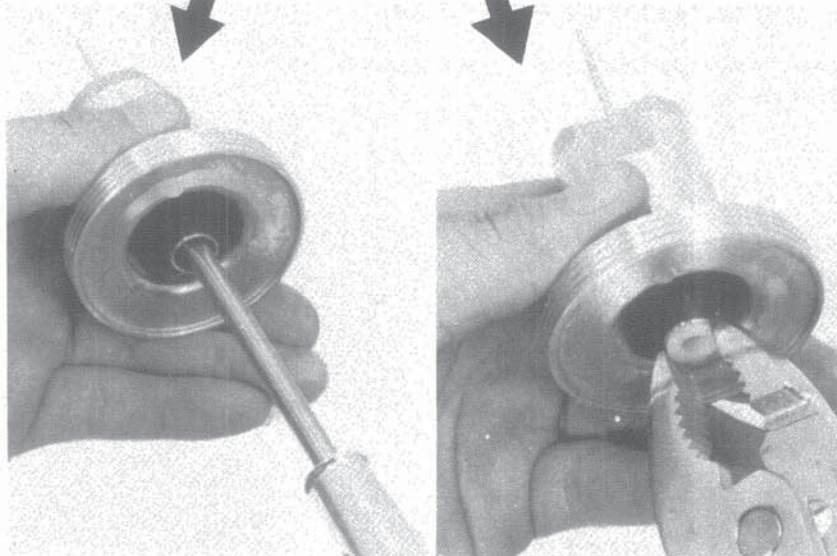

Remove the air jet cover.

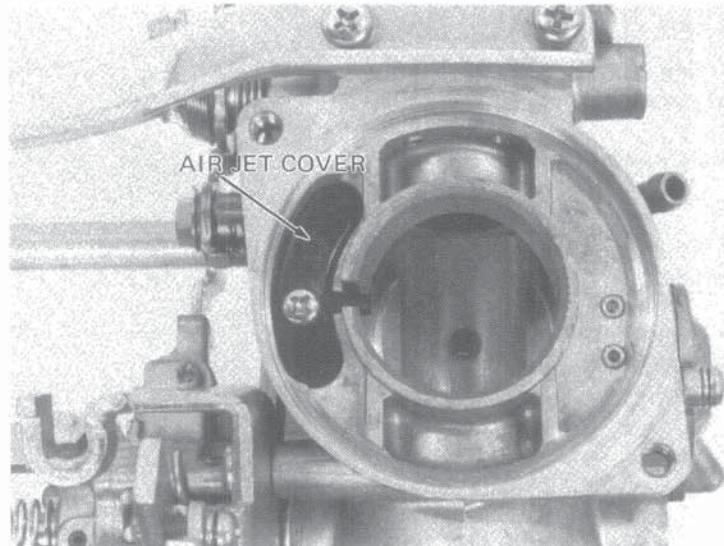





**FUEL SYSTEM**

Blow open the primary main air jet, secondary air jet, and slow air jet, with compressed air.

**NOTE**

Never clean carburetor jets with wire or drills. This will enlarge the openings and result in excessive fuel consumption.

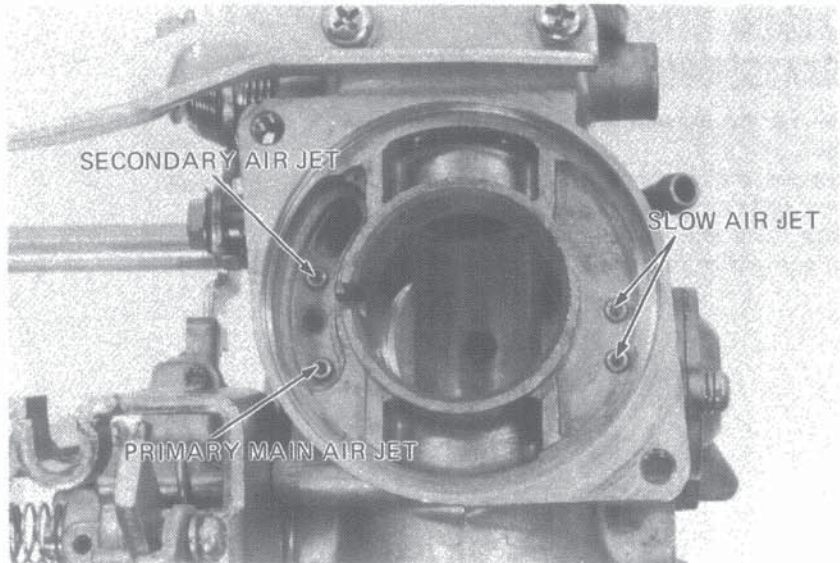

• **VACUUM PISTON INSPECTION**

Check the vacuum piston for free movement in the cylinder.

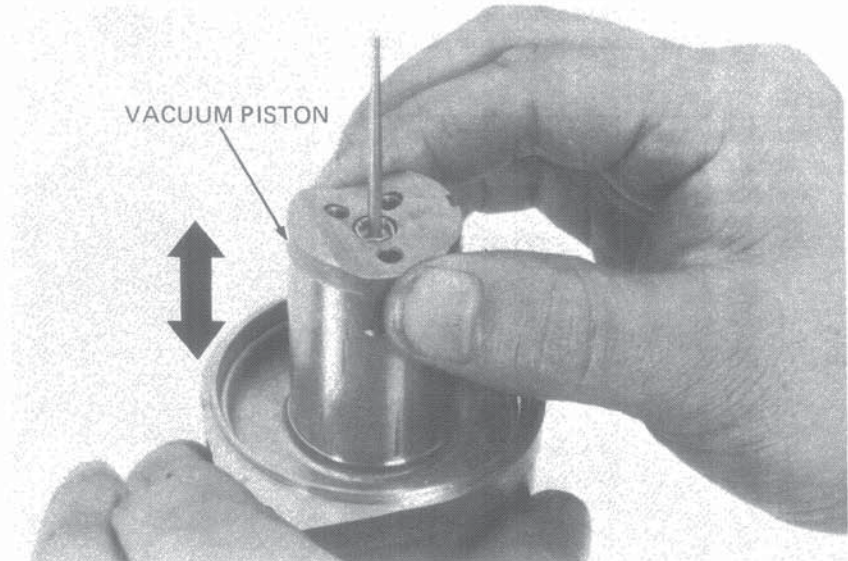

**FLOAT CHAMBER DISASSEMBLY**

- Remove the float chamber body.
- Remove the secondary main jet and jet needle holder.
- Remove the slow air jet plug.

**NOTE**

Do not try to remove the slow air jet. It is a press fit.

- Remove the primary main jet.
- Remove the pilot screw.

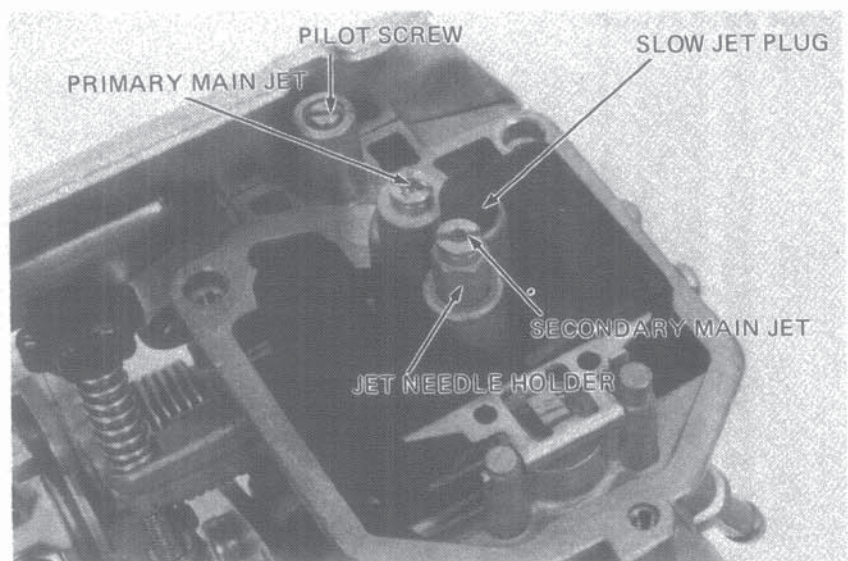





Remove the primary nozzle.

**NOTE**

Do not try to remove the slow air jet.  
It is a press fit.

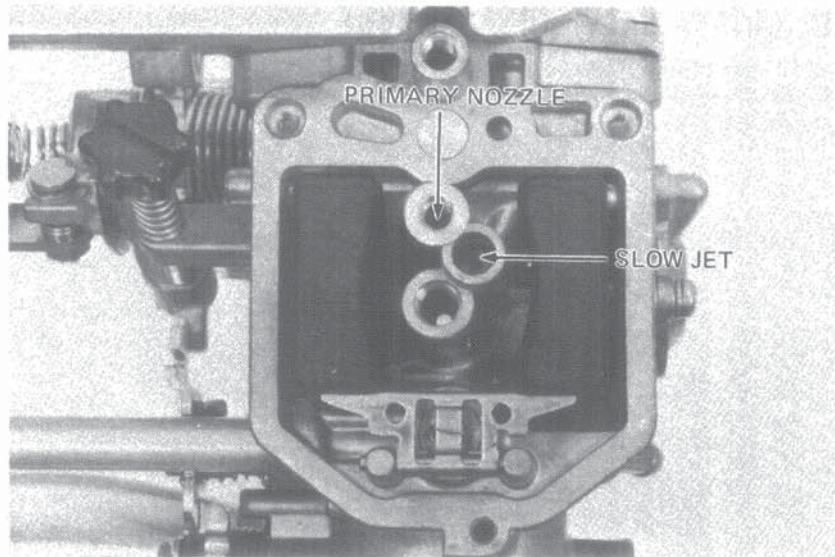

Remove the float arm pin using a needle nose plier.  
Remove the float and float valve.

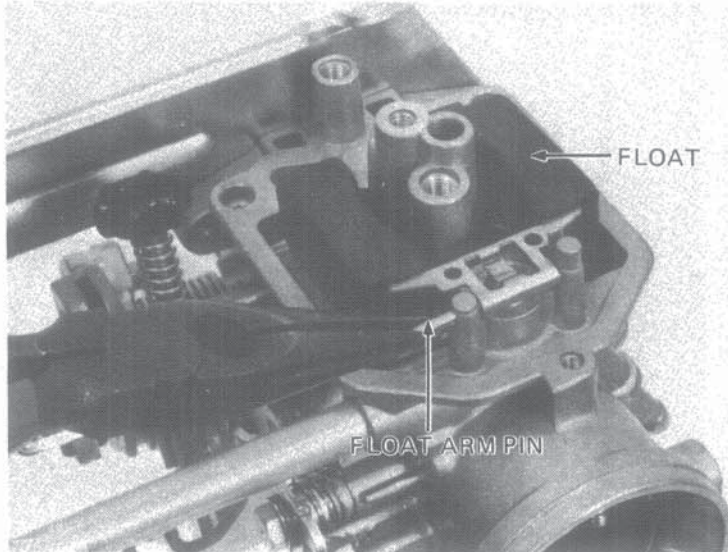

Inspect the float valve and seat for deposits,  
grooves or other damage.

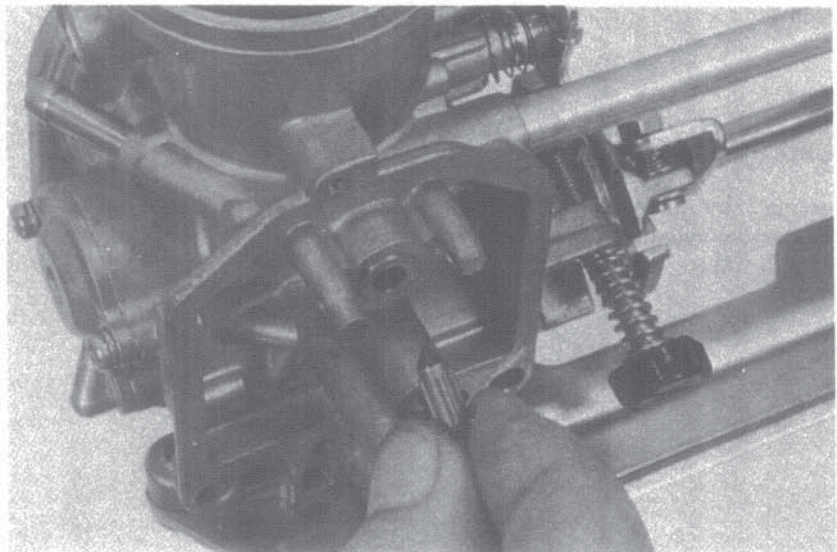





**FUEL SYSTEM**

**AIR CUTOFF VALVE DISASSEMBLY**

Remove the air cutoff valve cover and spring.  
Remove the diaphragm.  
Remove the O-ring.

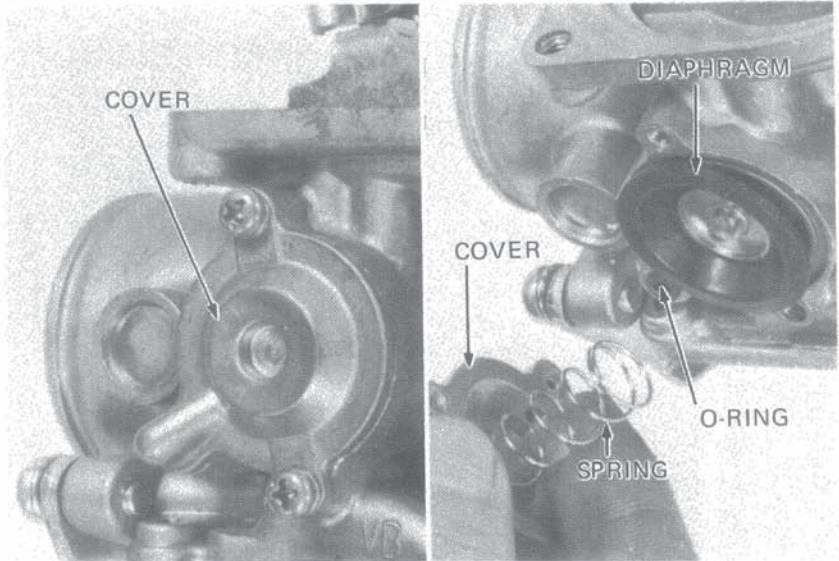

Inspect the air hoses and diaphragm for cracks and brittleness.

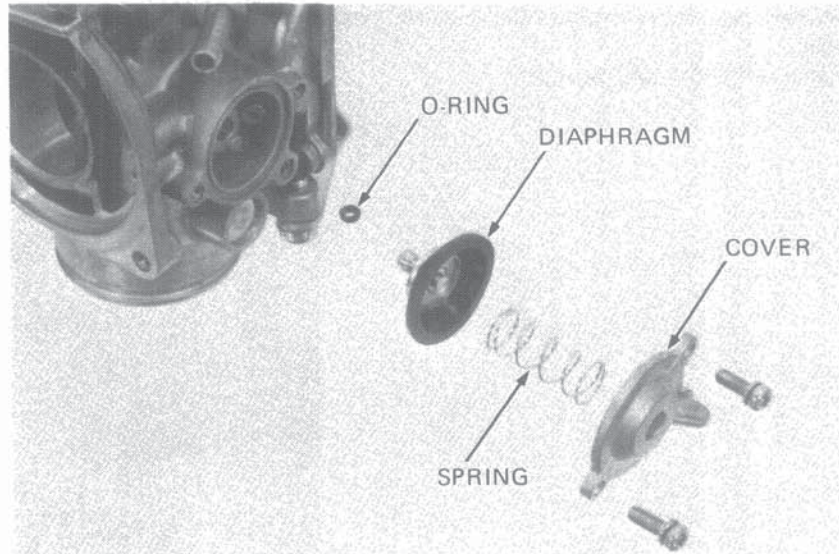

Clean the passages and jets with compressed air.

**COMPONENT ASSEMBLY**

Assemble the air cutoff valve, float chamber and vacuum cylinder in the reverse order of disassembly. Make sure the O-rings seat in their grooves.

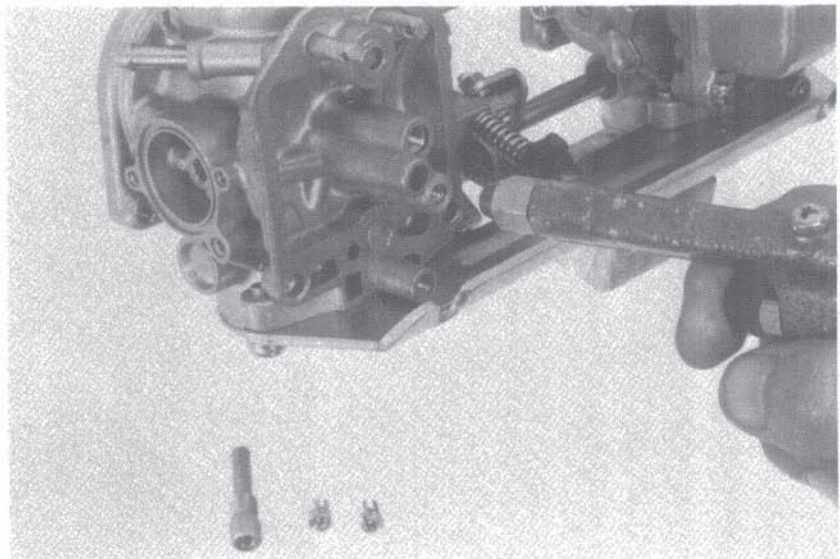





### FLOAT LEVEL ADJUSTMENT

Measure the float level.

Adjust the float level by bending the metal float arm with needle-nose pliers.

**FLOAT LEVEL: 15.5 mm (0.61 in)**

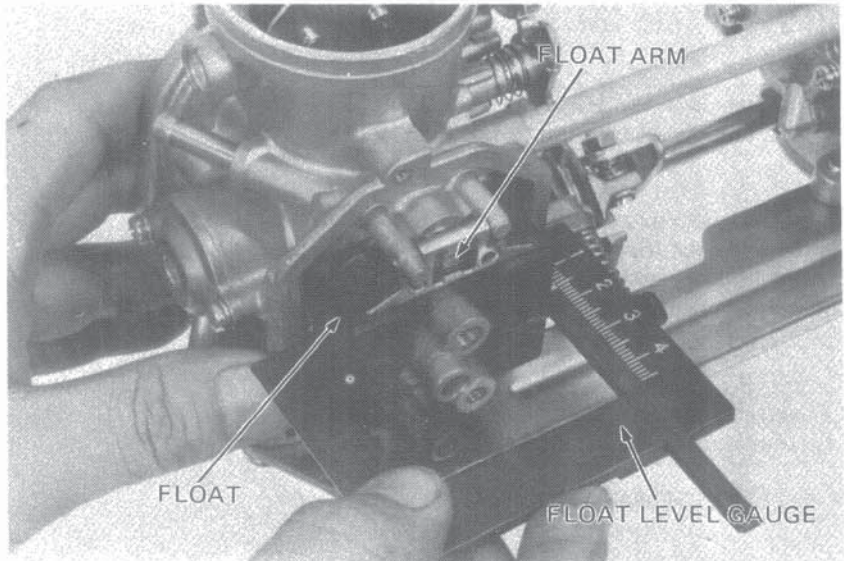

### FAST IDLE ADJUSTMENT

**FAST IDLE: 1,500-2,500 rpm**

If adjustment of the fast idle is necessary, remove the carburetor, and close the throttle valve by turning the throttle stop screw out.

Adjust by opening or closing the fork end of the fast idle lever until the clearance between the fast idle lever and throttle drum is about 0.8 mm (0.047 in).

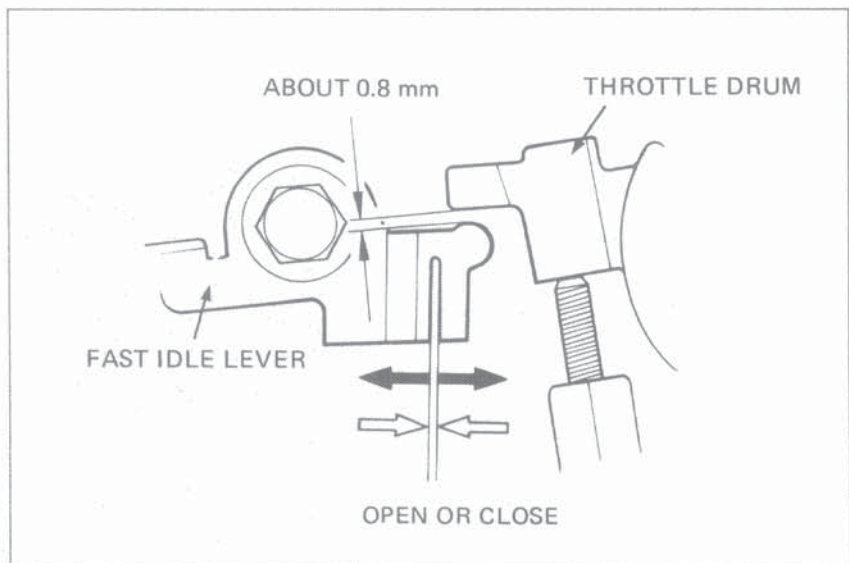

### CARBURETOR INSTALLATION

Installation is the reverse order of removal.

**NOTE**

Do not interchange the OPEN and RETURN throttle cables.

After installation, perform the following adjustments.

- Throttle grip free play (Page 3-5).
- Carburetor synchronization (Page 3-7).
- Idle speed adjustment (Page 3-6).
- Pilot screw setting and adjustment (Page 4-10).

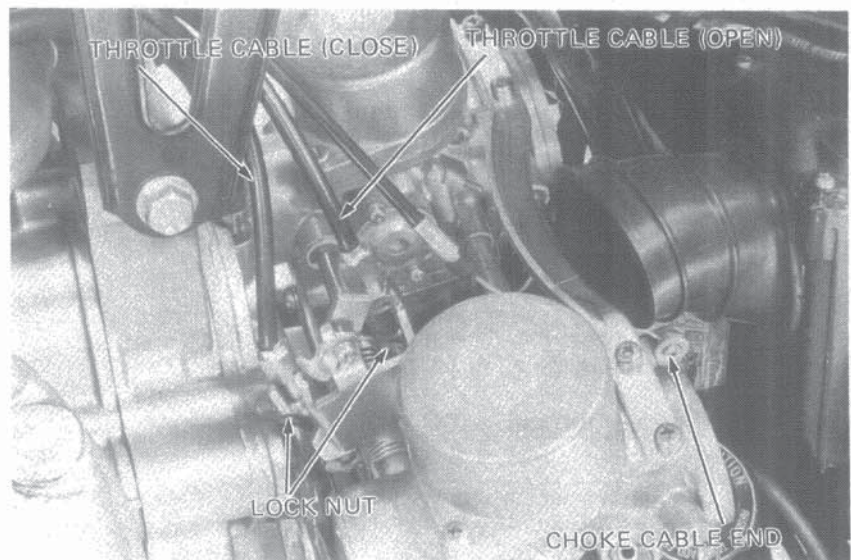





## PILOT SCREW INITIAL SETTING

### NOTE

The pilot screw is factory pre-set. Do not adjust unless the carburetor is overhauled.

Turn the pilot screw clockwise until it seats lightly and back it out to the specification. This is a preliminary setting prior to the final pilot screw adjustment.

### PILOT SCREW INITIAL OPENING: 2 turns

#### CAUTION

Damage to the pilot screw seat will occur if the pilot screw is tightened.

### PILOT SCREW ADJUSTMENT

### NOTE

Use a tachometer with graduations of 100 rpm.

1. Warm up the engine to operating temperature. Stop and go driving for approximately 10 minutes is sufficient.
2. Attach a tachometer.
3. Adjust the idle speed with the throttle stop screw.  
**IDLE SPEED: 1,100 ± 100 rpm**
4. Turn the pilot screw in or out to obtain the highest engine speed.
5. Readjust the idle speed with the throttle stop screw.
6. Turn the pilot screw in gradually until the engine speed drops 100 rpm.

### NOTE

If the pilot screw seats before lowering the engine speed 100 rpm, continue to step 7.

7. Turn the pilot screw 1 turns open from the position obtained in step 6.
8. Readjust the idle speed with the throttle stop screw.

### NOTE

Perform steps 4 thru 8 for the remaining carburetor.

### HIGH ALTITUDE ADJUSTMENT

The carburetor idle speed may have to be re-adjusted for high altitude riding above 2,000 m (6,500 ft).

### IDLE SPEED: 1,100 ± 100 rpm

### NOTE

Readjust the pilot screw if the engine idles rough, misses or stalls.

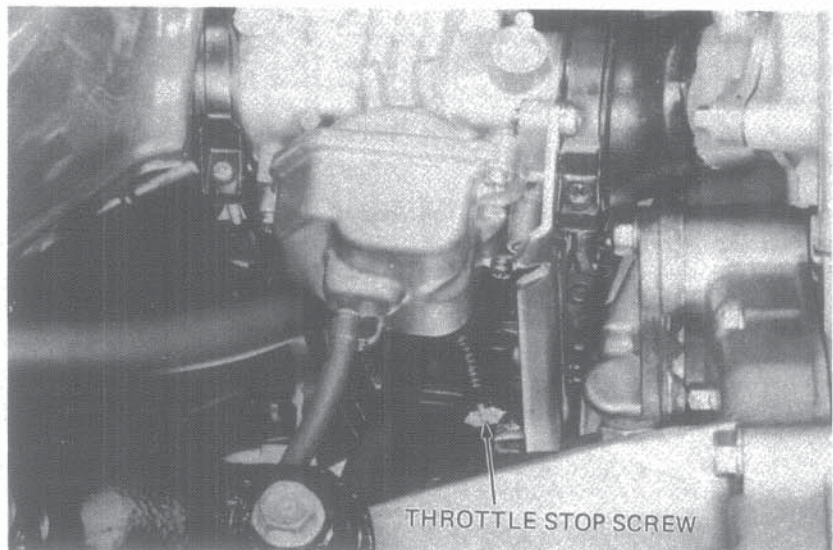
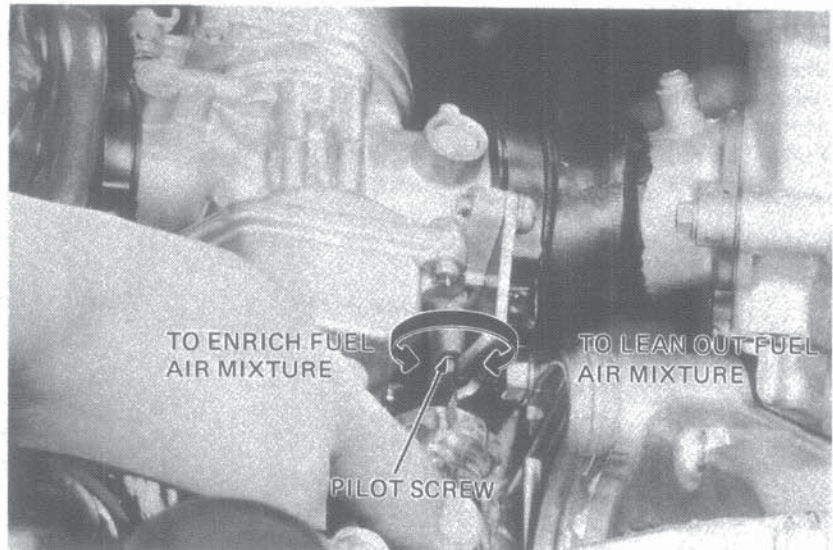





**FUEL TANK**

**WARNING**

*Keep gasoline away from open flames or sparks.  
Wipe up spilled gasoline at once.*

Check that fuel is flowing out of the fuel valve freely. If the fuel flow is restricted, clean the fuel strainer.

**NOTE**

Do not overtighten the fuel valve lock nut.  
Make sure there are no fuel leaks.

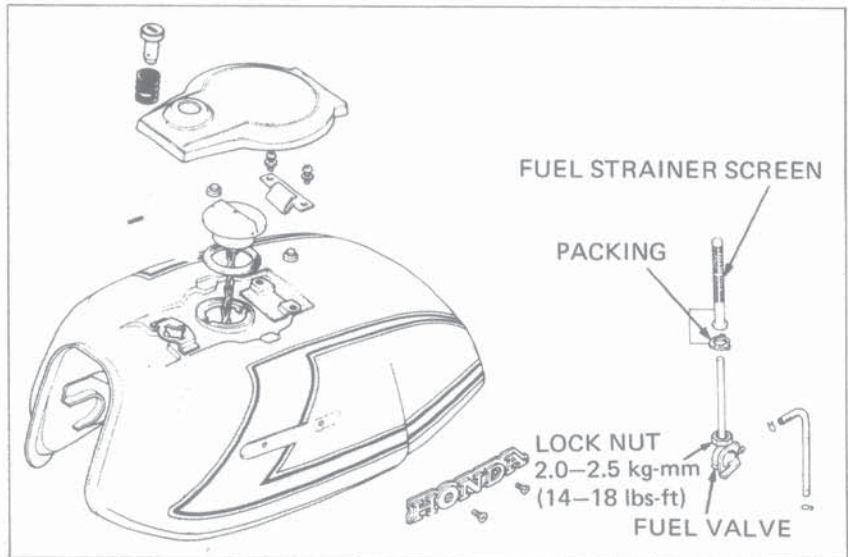

**AIR CLEANER CASE**

• **AIR CLEANER CASE REMOVAL**

Disconnect the taillight wires.  
Remove the hand rail, cowl and rear fender.

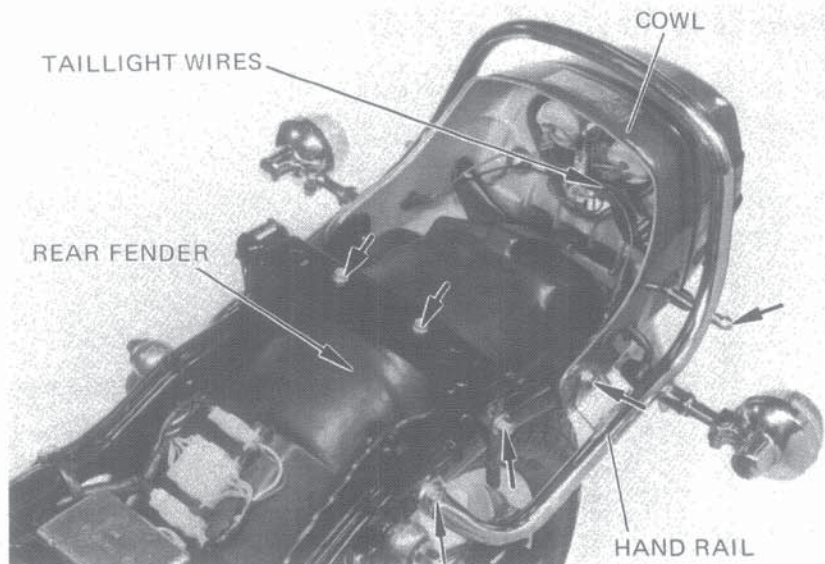

Remove the battery.  
Remove the starter magnetic switch and regulator/rectifier.  
Remove the carburetor spacer band.

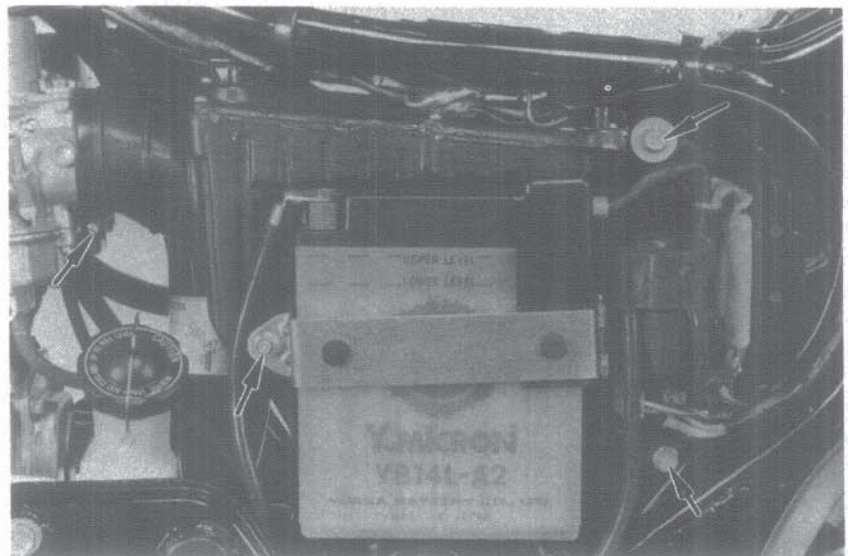





**FUEL SYSTEM**

Remove three bolts attaching the air cleaner plate, and pull the plate down.  
Remove the C.D.I. unit.  
Remove the air cleaner mounting bolt from under the C.D.I. unit.  
Remove the air cleaner from the right.

**NOTE**

Installation of the air cleaner is the reverse of removal.

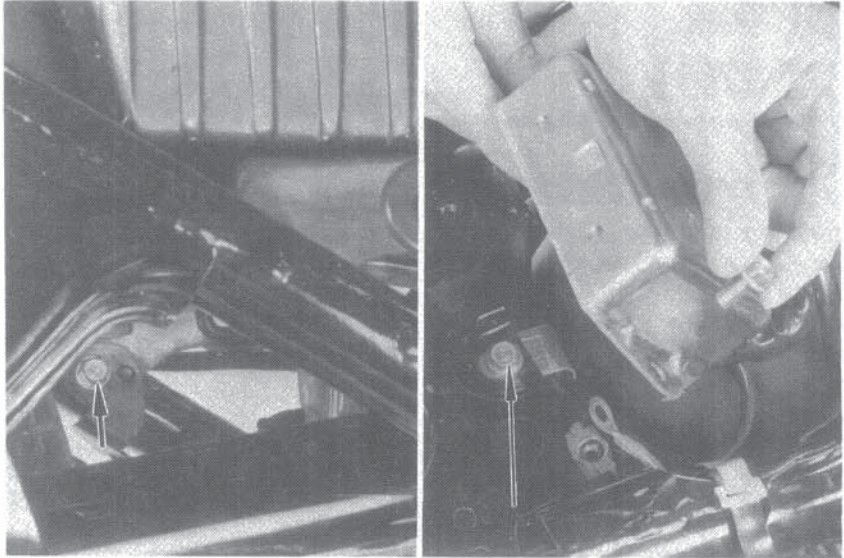

**CRANKCASE BREATHER SYSTEM**

**NOTE**

Check that the breather tube is not clogged or collapsed.

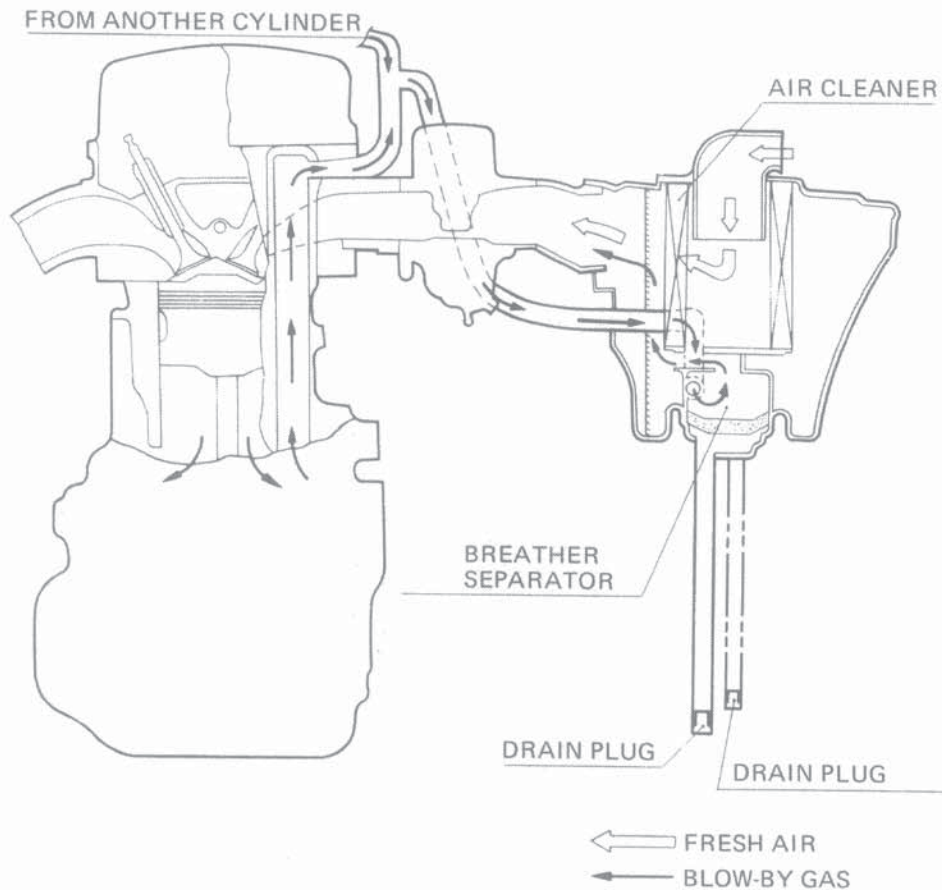

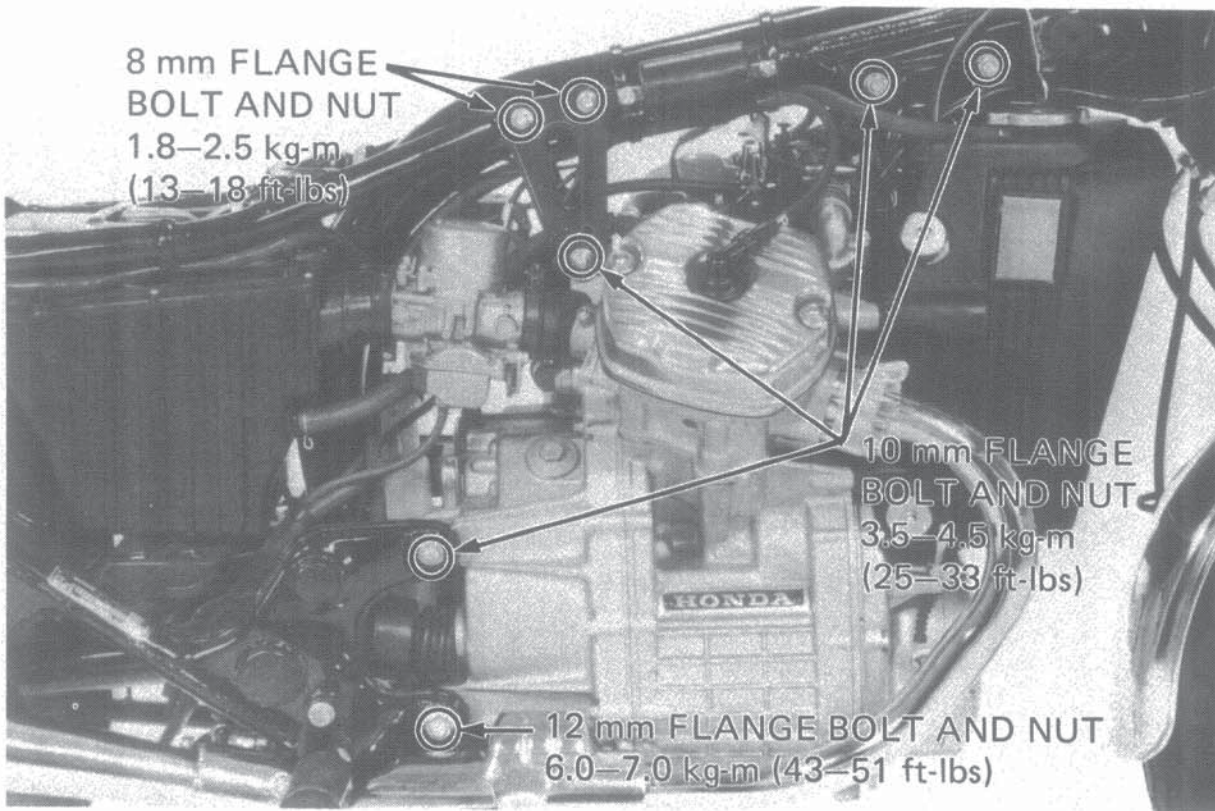

8 mm FLANGE  
BOLT AND NUT  
1.8–2.5 kg-m  
(13–18 ft-lbs)

10 mm FLANGE  
BOLT AND NUT  
3.5–4.5 kg-m  
(25–33 ft-lbs)

12 mm FLANGE BOLT AND NUT  
6.0–7.0 kg-m (43–51 ft-lbs)





SERVICE INFORMATION	5-1
ENGINE REMOVAL	5-2
ENGINE INSTALLATION	5-7

## SERVICE INFORMATION

### • WORKING PRACTICE

Parts requiring engine removal for servicing:

- Crankshaft, Piston
- Connecting rods
- Camshafts
- Flywheel and starting clutch
- Gearshift spindle
- Transmission
- Water pump mechanical seal

Remove and install the engine with a hydraulic jack to support its weight.

ENGINE WEIGHT: 67 kg (148 lbs)



## ENGINE REMOVAL

Turn the fuel valve off.  
 Remove the seat and fuel tank.  
 Remove the right and left side covers.  
 Disconnect the battery ground and starter motor cables.  
 Drain oil from the engine (Page 2-2).

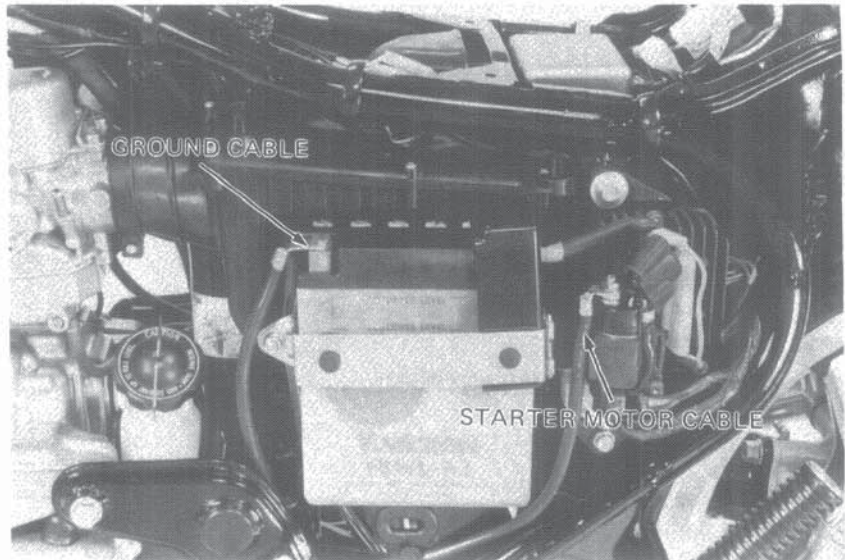

Loosen the 6 mm tachometer cable set bolt and pull the cable clear of the engine.  
 Disconnect the radiator bypass hose from the radiator.  
 Remove the breather hose.  
 Disconnect the clutch cable at the upper adjuster and remove it from the wire guide.

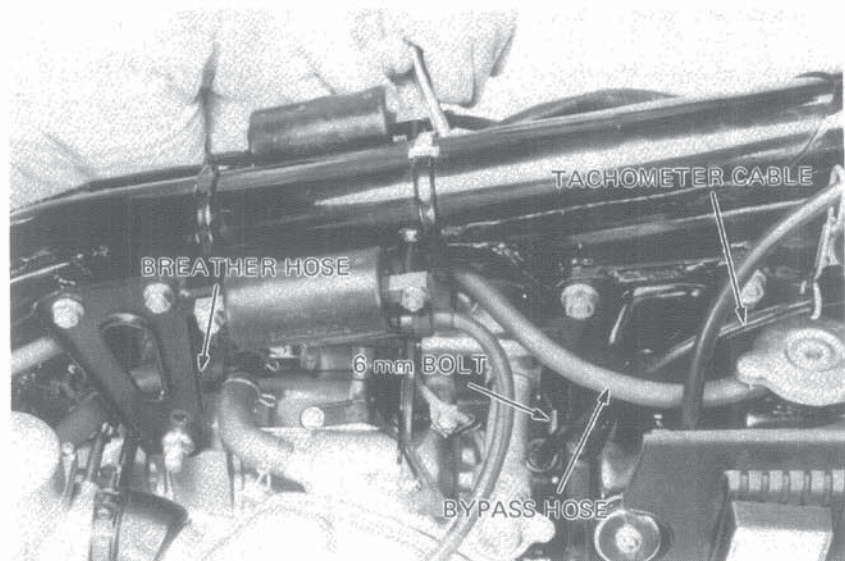

Disconnect the thermostatic switch wire (blue/red) and oil pressure gauge wire (green).  
 Remove the spark plug caps from the spark plugs.  
 Remove the 6 mm ignition coil mounting bolt at the rear.  
 Remove the engine hanger bolts and hanger plates.

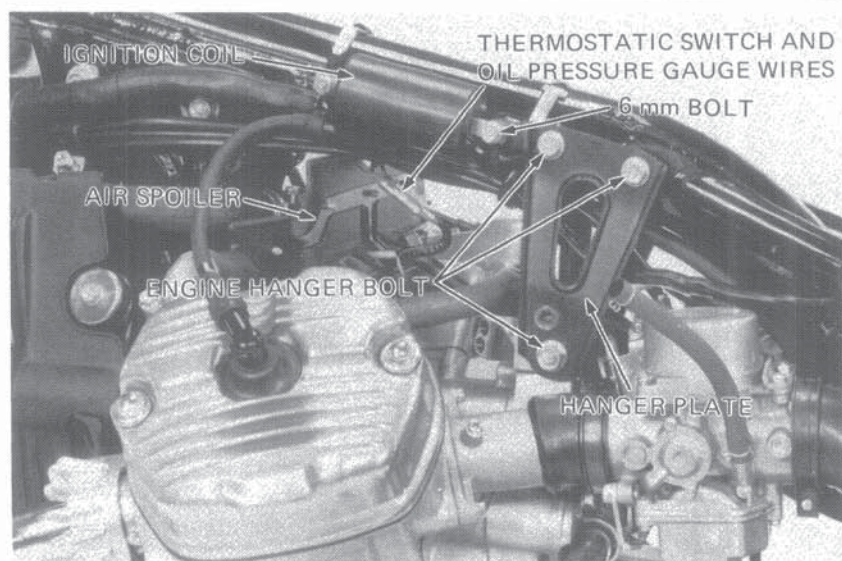





Remove the muffler mounting bolts.  
Loosen the muffler clamp bolts, and remove the exhaust mufflers.

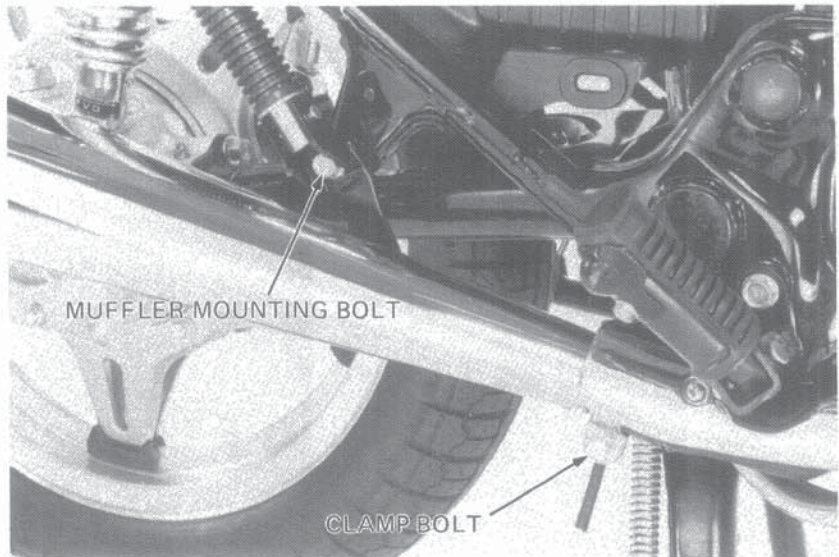

Remove the exhaust pipe clamp nuts.  
Loosen the exhaust pipe clamp bolts and remove the exhaust pipes.  
Loosen the carburetor band.

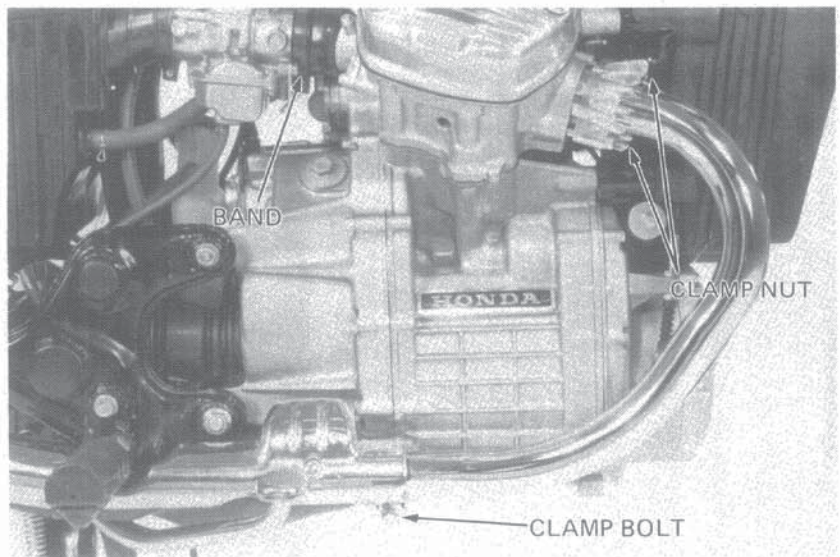

Remove the rear brake adjusting nut.  
Remove the rear brake pedal return spring.

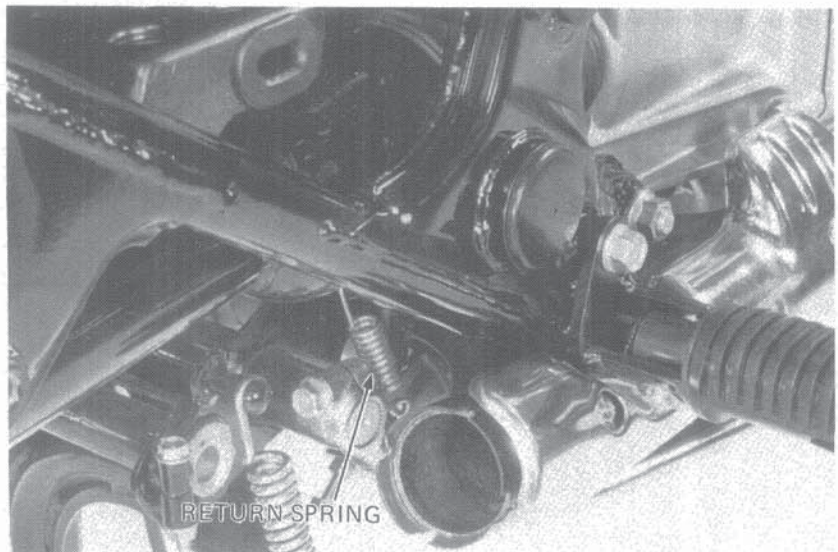





Remove the power chamber bolts.  
Remove the power chamber.

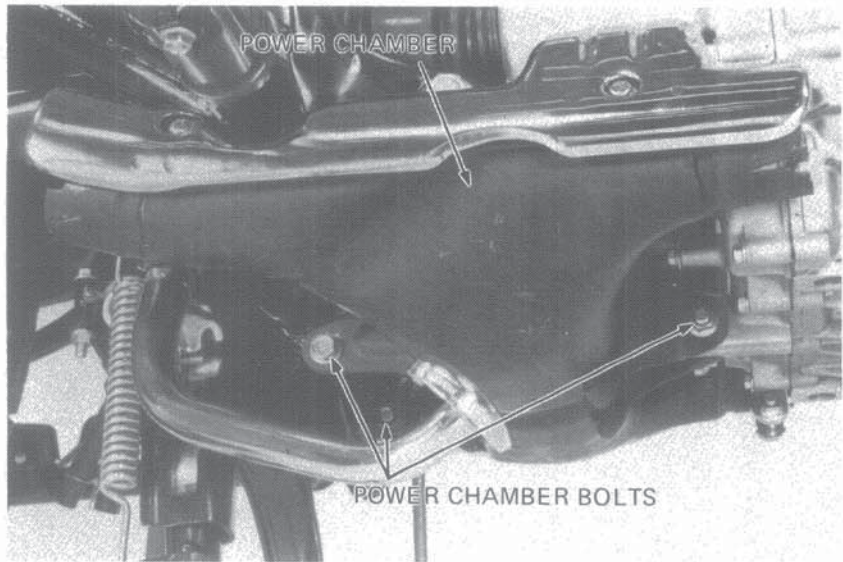

Remove the wire harness bands.  
Disconnect the C.D.I. unit and A.C. generator cables at the couplers.  
Disconnect the ignition coil cords.  
Pull the wire harnesses clear of the frame.

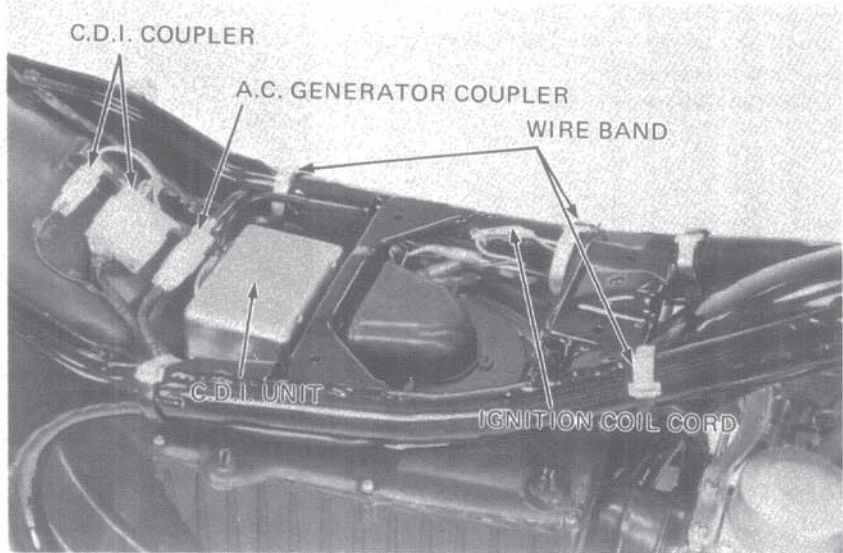

Remove the drive shaft lock bolt.

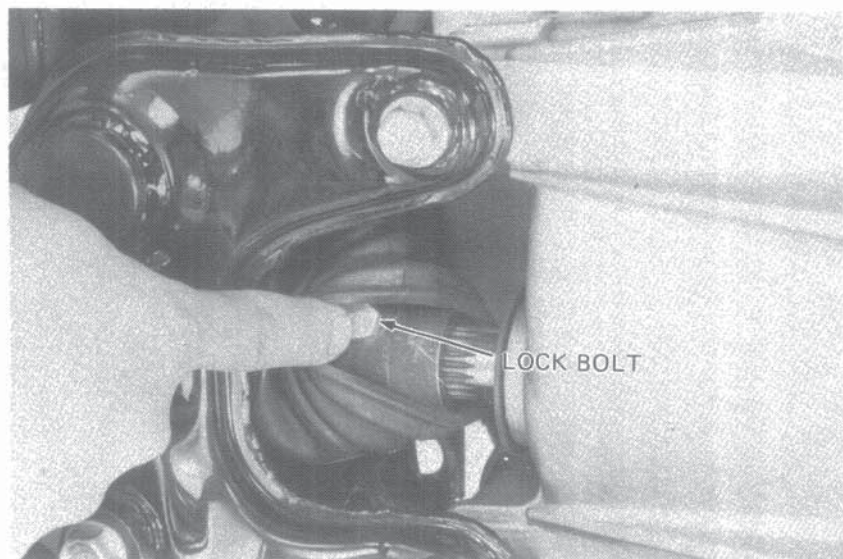





Place a jack under the engine to support its weight.  
Remove the engine rear mounting bolts.

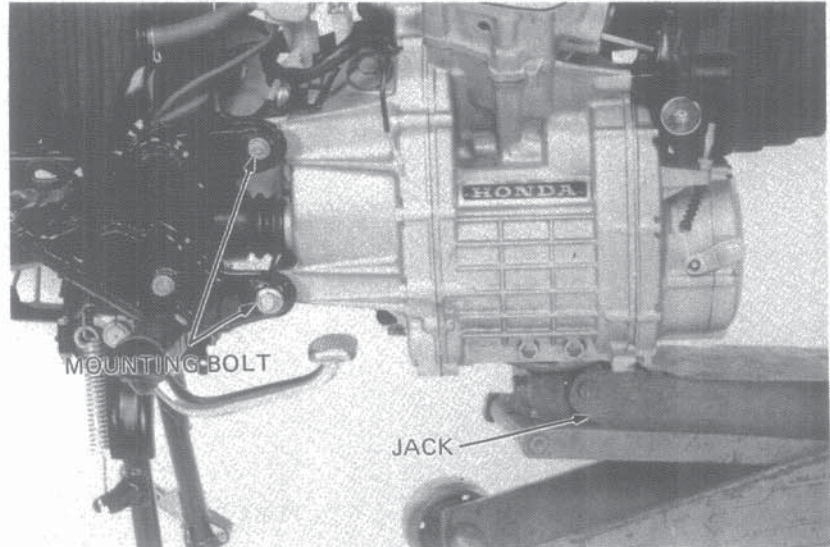

Remove the engine front hanger bolts.

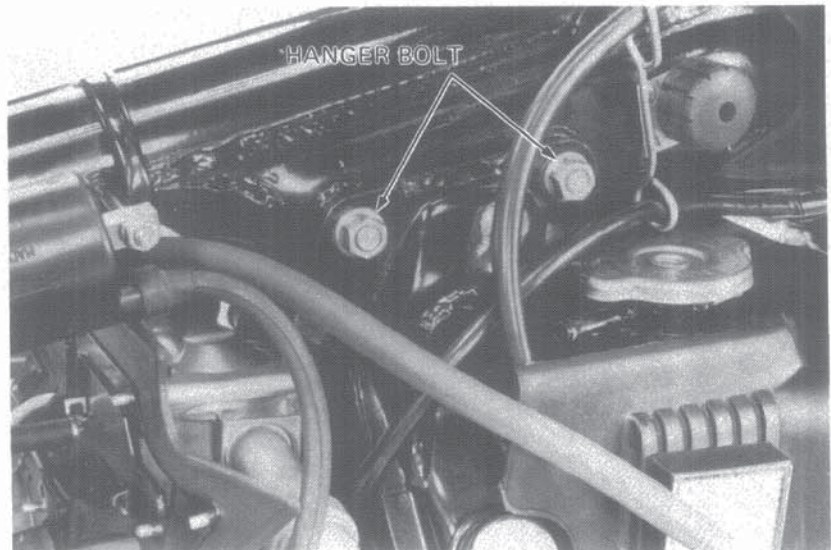

Disengage the final shaft from the U-joint assembly by adjusting the jack height and moving the engine forward.  
Remove the engine from the frame.

**CAUTION**

*Jack height must be continuously adjusted during engine removal and installation to prevent damage to mounting bolt threads, wire harnesses and cables.*

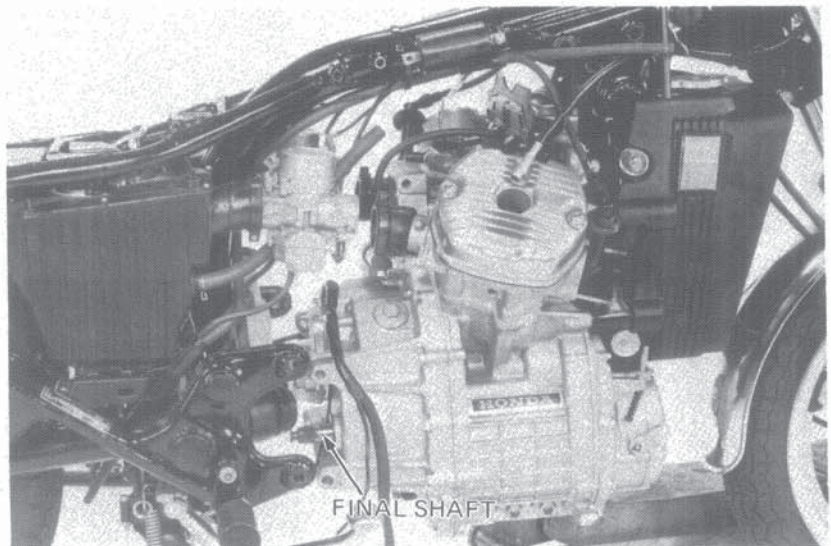





Disconnect the water pump bypass hose.  
Remove the air spoiler.  
Remove the grommets and 6 mm screws.  
Remove the radiator cover.  
Remove the radiator mounting bolts.

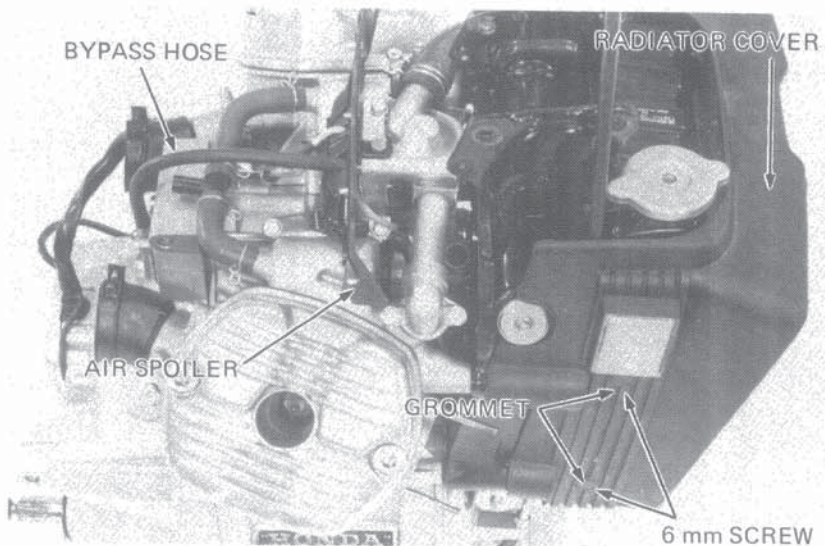

Loosen the radiator cap.  
Remove the radiator drain bolt, and drain the coolant.  
Loosen the radiator upper and lower hose bands.  
Remove the radiator mount bolts.  
Remove the radiator while pulling off the upper hose.

**NOTE**

Do not damage the radiator fins.

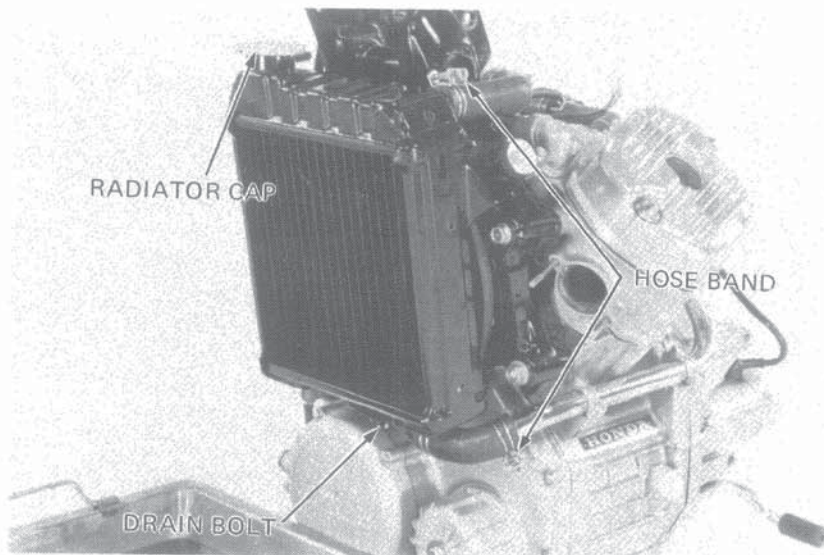

Remove the front engine hanger.  
Remove the clutch wire.

**NOTE**

If the cylinder heads must be removed, remove the cylinder drain bolts, and drain the coolant.

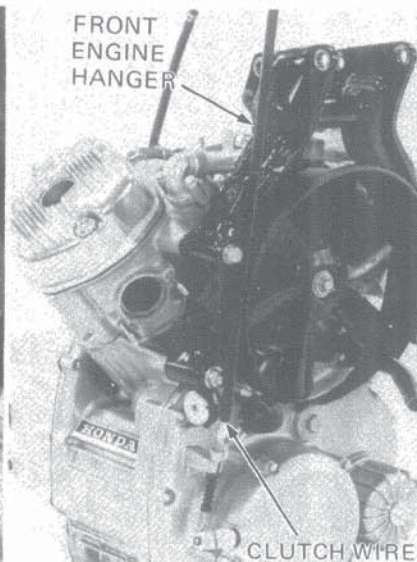
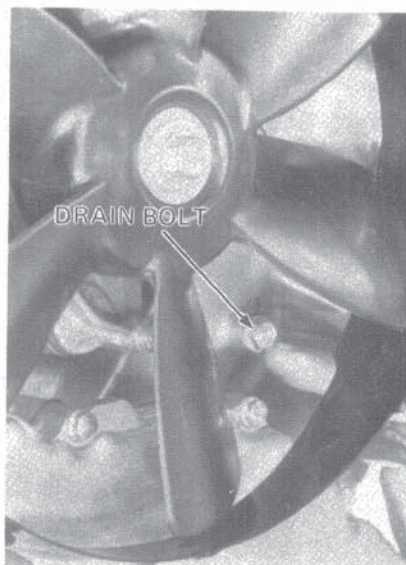





### ENGINE INSTALLATION

The installation sequence is essentially the reverse of removal.

Place the transmission into gear.

Raise the engine with a jack and align the drive shaft with the final shaft.

Slide the drive shaft into the U-joint assembly by moving the engine backward.

#### NOTE

Make sure that the final shaft splines are exposed 5–6 mm from the end of the U-joint.

Torque the lock bolt securely.

**TORQUE VALUE: 1.8–2.5 kg-m  
(13–18 ft-lbs)**

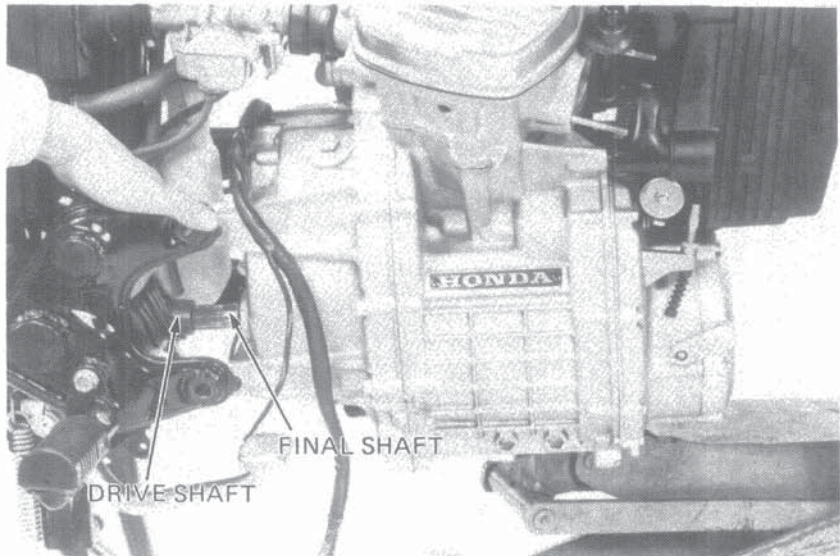

- Align the mounting surfaces carefully to prevent damage to mounting bolt threads, wire harnesses and cables.
- Route the wires and cables properly (Page 1-8).
- Fill the engine with the recommended oil.
- Perform the following adjustments:  
Throttle cable free play (Page 3-5).  
Clutch lever free play (Page 3-13).

#### WARNING

*Insert the upper engine hanger bolts from the left. The bolts have rounded heads to prevent chafing of the main wire harness.*

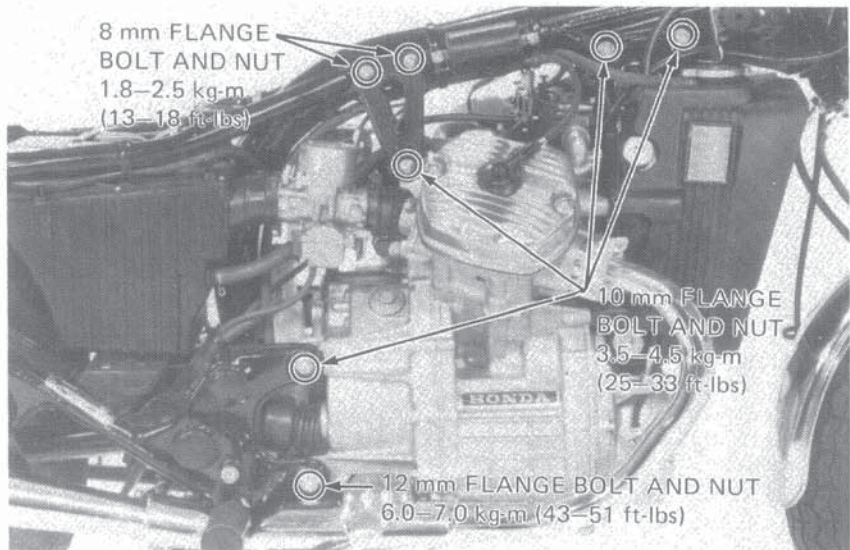

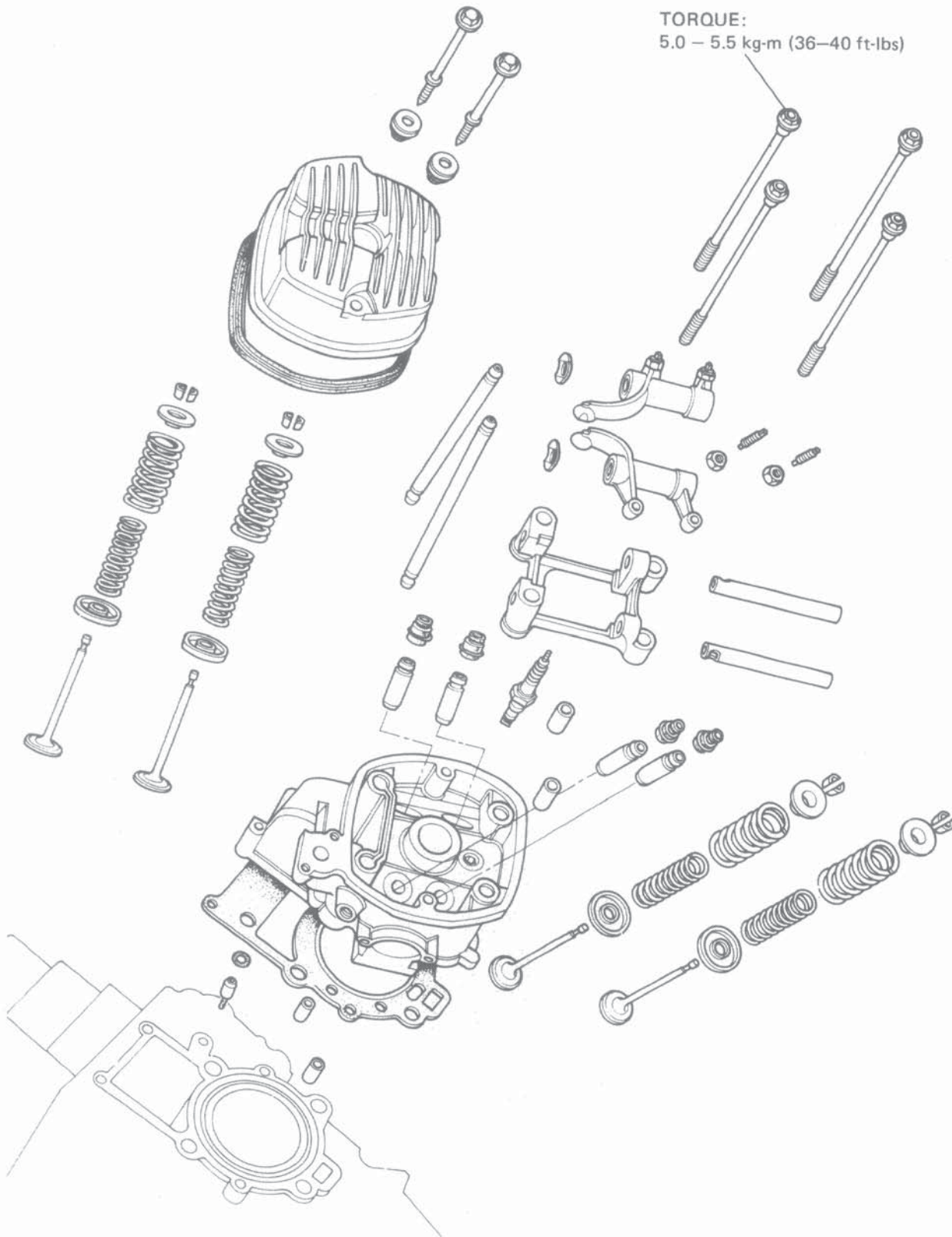





SERVICE INFORMATION	6-1
TROUBLESHOOTING	6-2
ROCKER ARM/CYLINDER HEAD REMOVAL	6-3
CYLINDER HEAD DISASSEMBLY	6-6
VALVE GUIDE REPLACEMENT	6-9
VALVE SEAT INSPECTION AND GRINDING	6-10
CYLINDER HEAD ASSEMBLY	6-13
ROCKER ARM ASSEMBLY	6-14
CYLINDER HEAD/ROCKER ARM INSTALLATION	6-15

## SERVICE INFORMATION

### • WORKING PRACTICE

All cylinder head maintenance and inspection can be accomplished with the engine installed. Before removing the cylinder heads, it is necessary to drain coolant from the cylinder water jackets by removing the drain bolts.

### • SPECIAL TOOLS

#### Special tools

VALVE GUIDE DRIVER ATTACHMENT (IN/EX) 07943-415000  
VALVE GUIDE REAMER (IN/EX) 07984-6110000

#### Common tools

VALVE SPRING COMPRESSOR 07757-0010000  
VALVE GUIDE REMOVER (6.6 mm) (IN/EX) 07742-0010200

**• SPECIFICATIONS**

			Standard	Service Limit
Cylinder compression (cold)			12 ± 2 kg/cm <sup>2</sup> / 700 rpm	—
Rocker arms	Shafts and holders	Rocker arm I.D.	14.016–14.027 mm (0.5518–0.5522 in.)	14.05 mm (0.5531 in.)
		Rocker arm shaft O.D.	13.982–14.000 mm (0.5505–0.5512 in.)	13.96 mm (0.5496 in.)
		Rocker arm holder I.D.	14.00 –14.027 mm (0.5512–0.5522 in.)	14.05 mm (0.5531 in.)
Valve spring	Free length	Outer (IN)	50.4 mm (1.9842 in.)	48.5 mm (1.9094 in.)
		Inner (IN)	50.3 mm (1.9803 in.)	48.4 mm (1.9055 in.)
		Outer (EX)	50.4 mm (1.9842 in.)	48.5 mm (1.9094 in.)
		Inner (EX)	50.3 mm (1.9803 in.)	48.4 mm (1.9055 in.)
	Preload/Length	Outer (IN)	28 kg/39.9 mm (61.7 lbs/1.5709 in.)	26.5 kg/39.8 mm (58.4 lbs/1.5670 in.)
		Inner (IN)	11.5 kg/37.9 mm (25.4 lbs/1.4921 in.)	10.5 kg/37.9 mm (23.2 lbs/1.4921 in.)
		Outer (EX)	28.5 kg/39.9 mm (62.8 lbs/1.5709 in.)	26.5 kg/39.8 mm (58.4 lbs/1.5670 in.)
		Inner (EX)	11.5 kg/37.9 mm (25.4 lbs/1.492 in.)	10.5 kg/37.9 mm (23.2 lbs/1.4921 in.)
Valves and valve guides	Stem O.D.	(IN)	6.580– 6.590 mm (0.2591–0.2594 in.)	6.54 mm (0.2575 in.)
		(EX)	6.550– 6.560 mm (0.2579–0.2583 in.)	6.54 mm (0.2565 in.)
	Guide I.D.	(IN)	6.6000–6.6200 mm (0.2598–0.2606 in.)	6.70 mm (0.2638 in.)
		(EX)	6.6000–6.6200 mm (0.2598–0.2606 in.)	6.70 mm (0.2638 in.)
	Stem-to-guide clearance	(IN)	—	0.10 mm (0.040 in.)
		(EX)	—	0.10 mm (0.040 in.)
Cylinder head	Valve seat width	1.1–1.3 mm (0.04–0.05 in.)	2.0 mm (0.08 in.)	
	Warpage	—	0.10 mm (0.040 in.)	

**TROUBLESHOOTING**

Engine top-end problems are usually performance related which can be diagnosed by a compression test, or are noises which can usually be traced to the top-end with a sounding rod or stethoscope.

**Low Compression or Uneven Compression**

1. Valve
  - Incorrect valve clearance
  - Burned or bent valves
  - Broken valve spring
  - Incorrect valve timing
  - Sticking valve
2. Cylinder head
  - Leaking or damaged head gasket
  - Warped or cracked cylinder head
3. Cylinder and piston

**High Compression**

1. Excessive carbon build-up on piston crown or combustion chamber

**Excessive Noise**

1. Incorrect valve adjustment
2. Sticking valve or broken valve spring
3. Damaged rocker arm or camshaft
4. Bent push rod

**Contaminated Engine Oil or Coolant**

1. Leaking head gasket





## ROCKER ARM/CYLINDER HEAD REMOVAL

Disconnect the thermometer and oil pressure gauge wires.

Remove the by-pass hose.

Remove the air spoiler.

Remove the spark plug caps.

Remove the cylinder head cover.

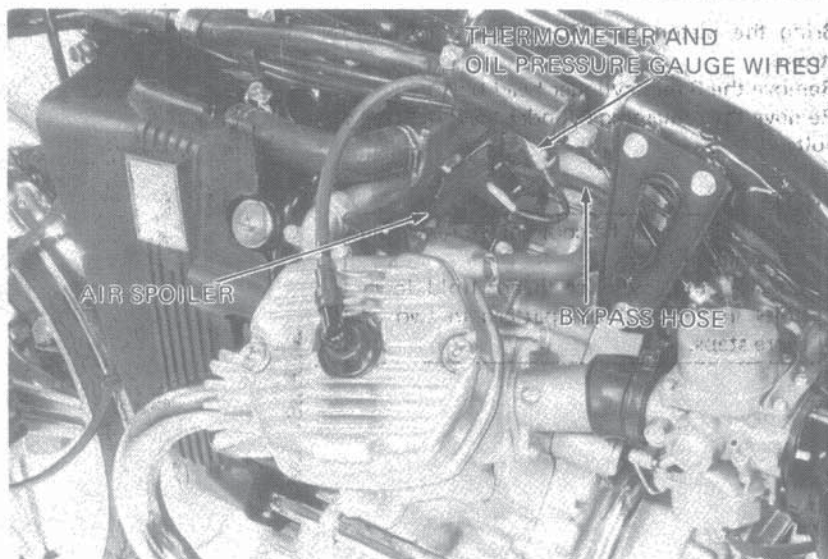

Remove the radiator cover (Page 9-3).

Remove the radiator drain bolt and drain the coolant.

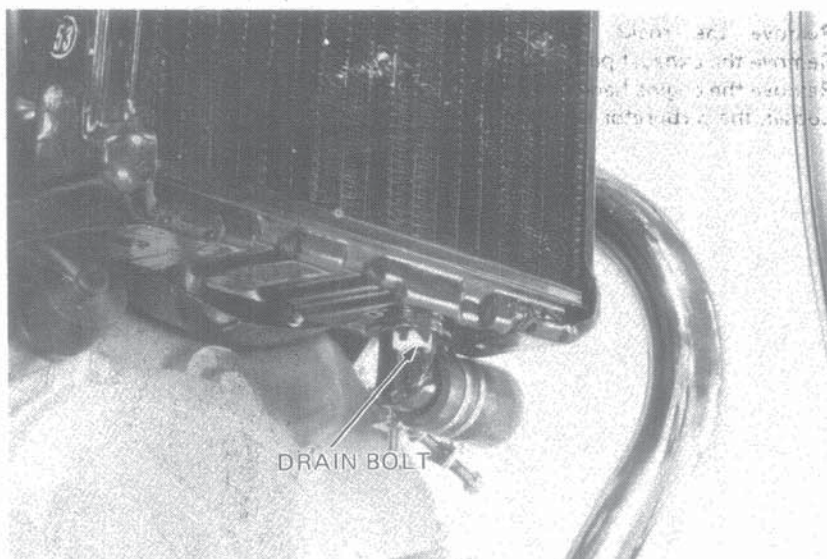

Remove the cylinder drain bolts to drain the coolant.

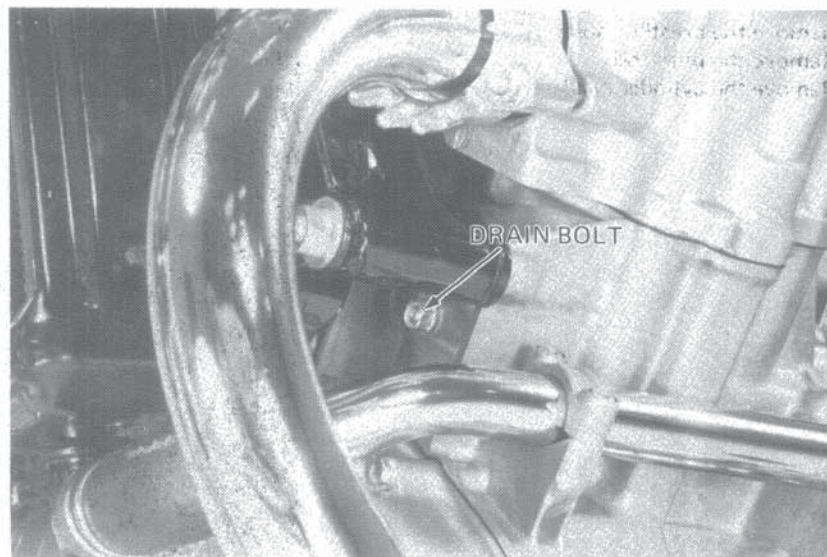





Bring the piston to TDC of the compression stroke.

Remove the 6 mm cylinder head bolts.

Remove the remaining cylinder head hold-down bolts.

**NOTE**

The engine must be cool before removing the cylinder heads.

Loosen the cylinder head hold-down bolts in a criss cross pattern in two or more steps.

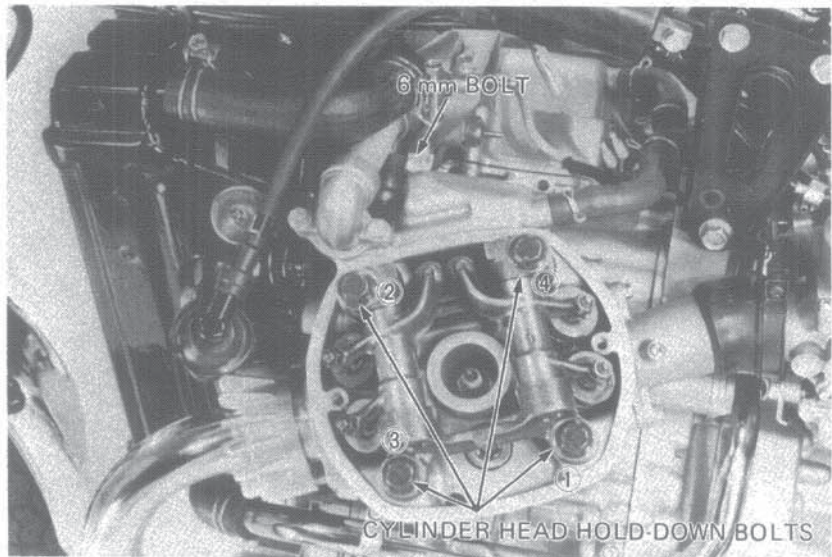

Remove the rocker arm holder assembly.

Remove the exhaust pipe.

Remove the engine hanger bolts.

Loosen the carburetor insulator band.

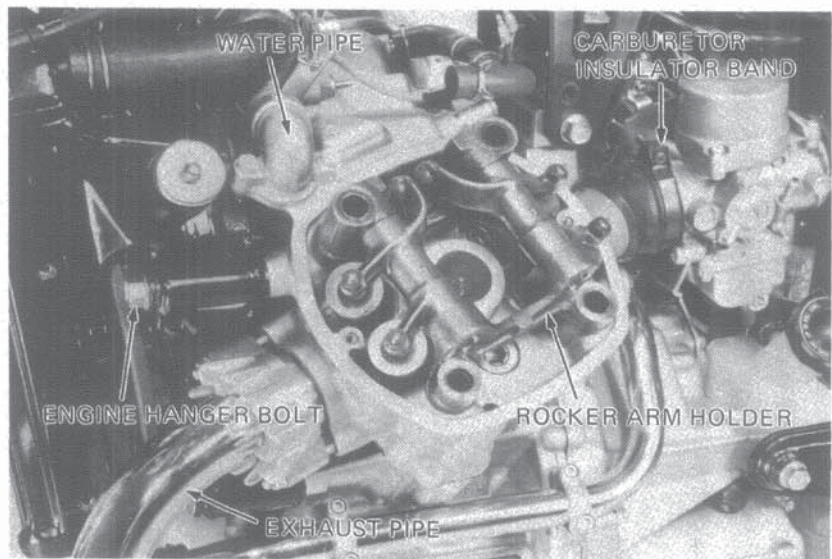

Remove the breather hose.

Remove the push rods.

Remove the cylinder head.

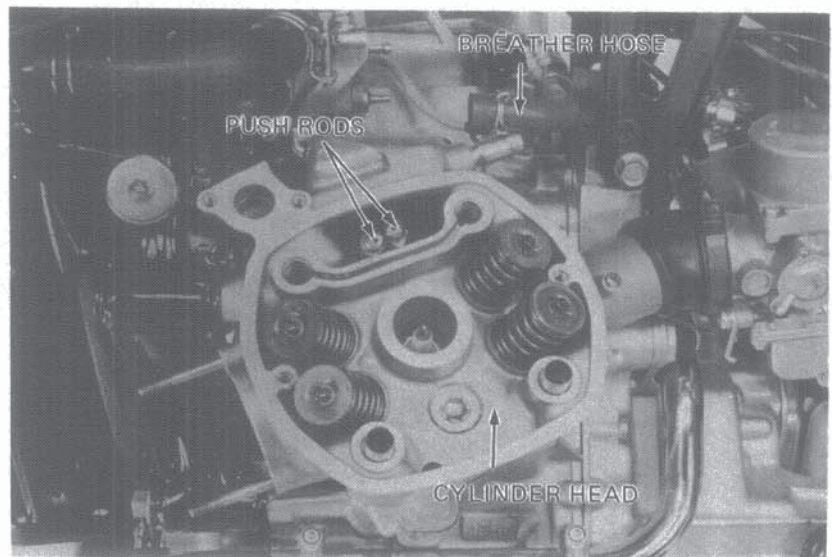





Remove the cylinder head gasket, dowel pins and O-rings.

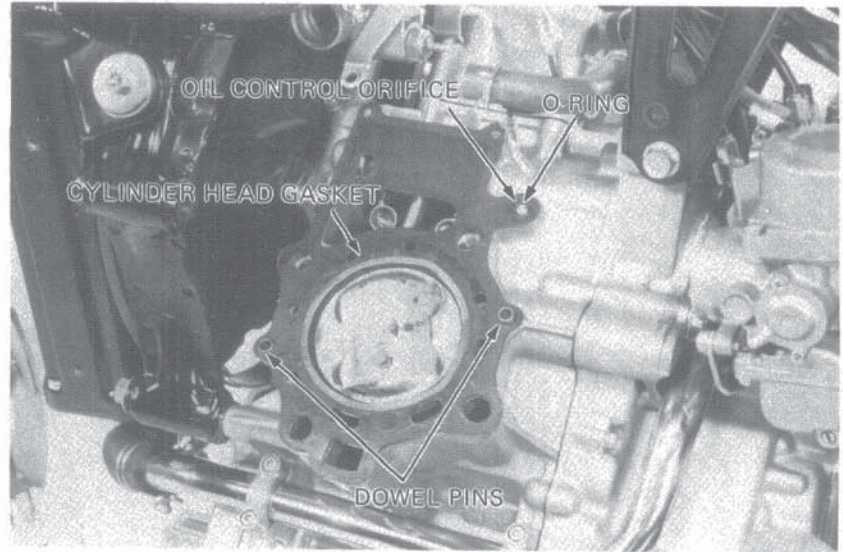

• **ROCKER ARM HOLDER DISASSEMBLY**

Withdraw the rocker arm shafts and remove the wave washers and rocker arms.

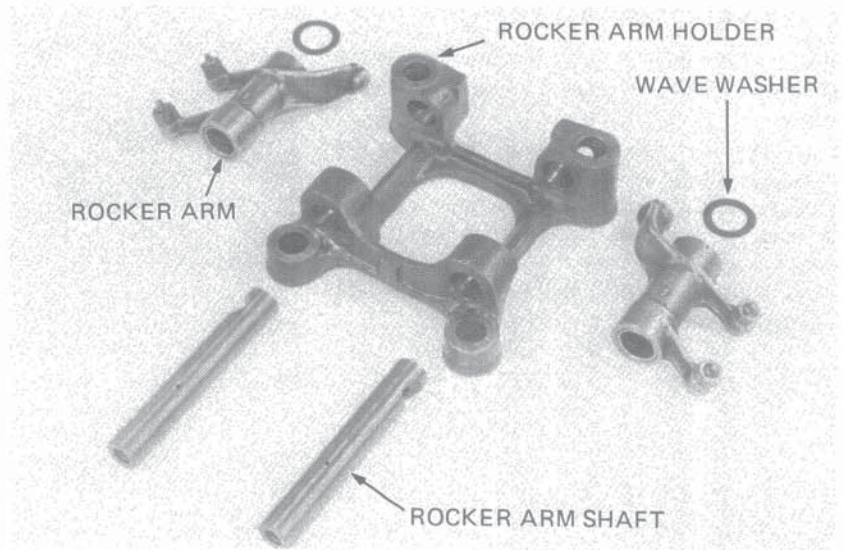

• **ROCKER ARM SHAFT INSPECTION**

Measure the O.D. of each rocker arm shaft. Examine the wave washers for damage. Inspect each shaft for damage, scoring or nicks.

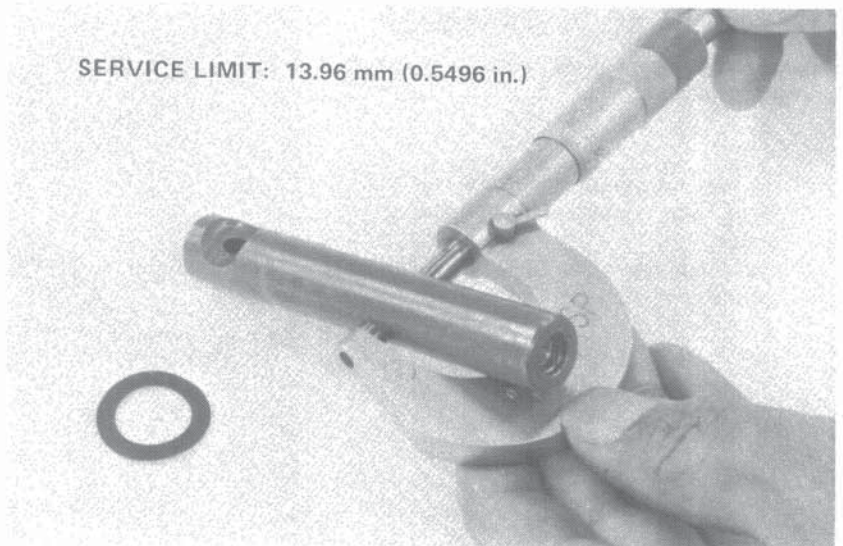





**CYLINDER HEAD/VALVE**

• **ROCKER ARM HOLDER INSPECTION**

Measure the rocker arm holder I.D.

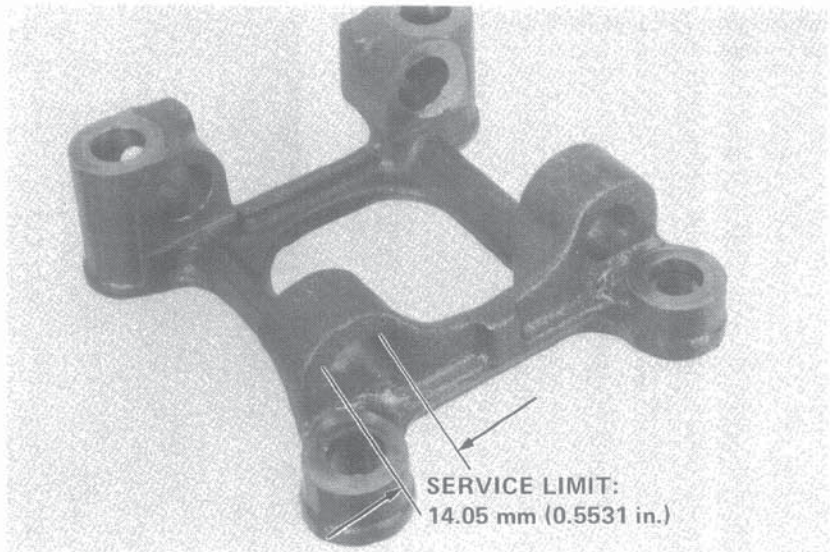

• **ROCKER ARM INSPECTION**

Inspect each rocker arm for scoring, damage, or clogged oil holes. Measure the arm I.D. of each rocker.

If a rocker arm shows wear or damage to the adjusting screw or push rod contact faces, inspect the push rods and stem contact faces for scoring, scratches, or evidence of insufficient lubrication.

Inspect the push rods for wear, damage and trueness.

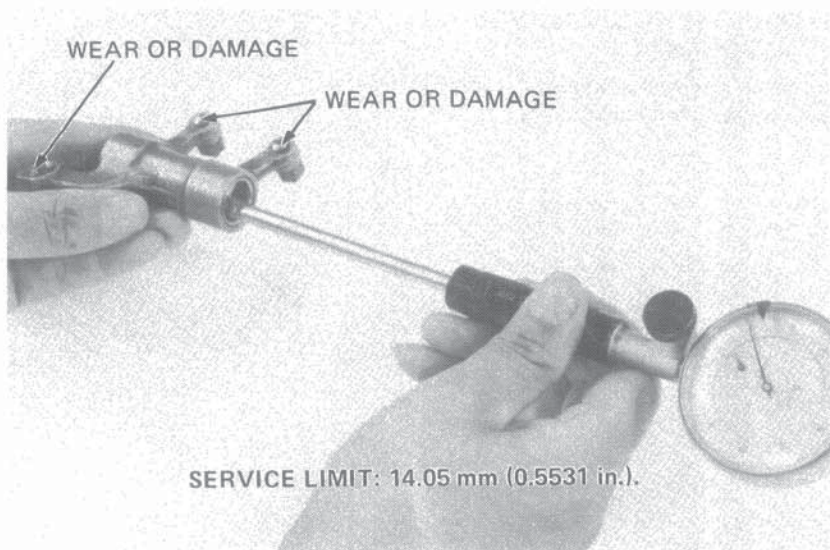

**CYLINDER HEAD DISASSEMBLY**

Remove the valve spring cotters, retainers, springs and valve.

**NOTE**

- Do not compress the valve springs more than necessary to remove the cotters.
- Mark all parts to ensure original assembly.

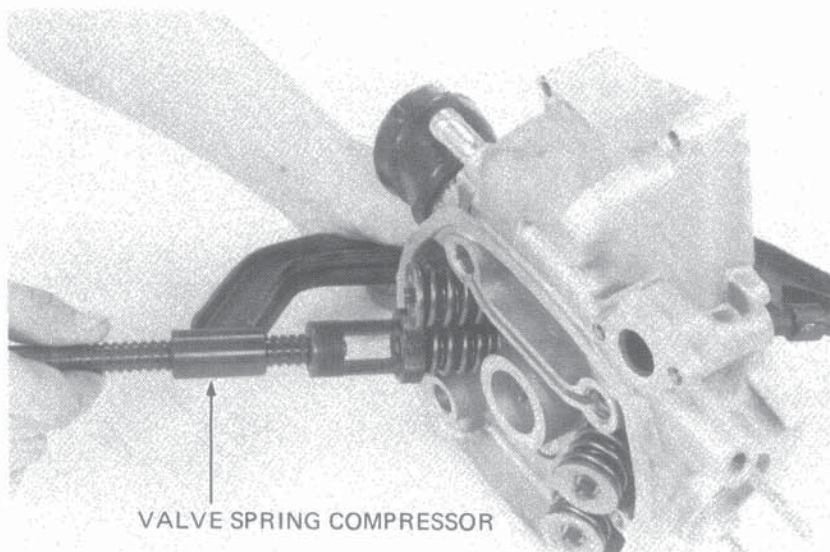





Remove carbon deposits from the combustion chambers.  
Remove any gasket material from the head surfaces.

### NOTE

- Do not damage the gasket surfaces.
- Avoid dropping gasket material into the jackets or oil passages.
- Gaskets will come off easier if soaked with solvent.

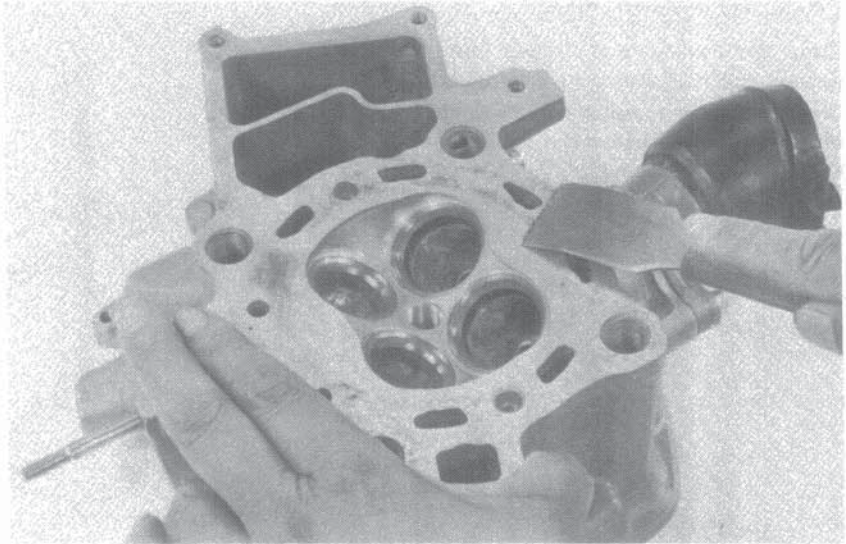

### • CYLINDER HEAD INSPECTION

Check the spark plug hole and valve areas carefully for cracks.  
Check the cylinder head for warpage with a straight edge and a feeler gauge.

### NOTE

Check for warpage in an X pattern.

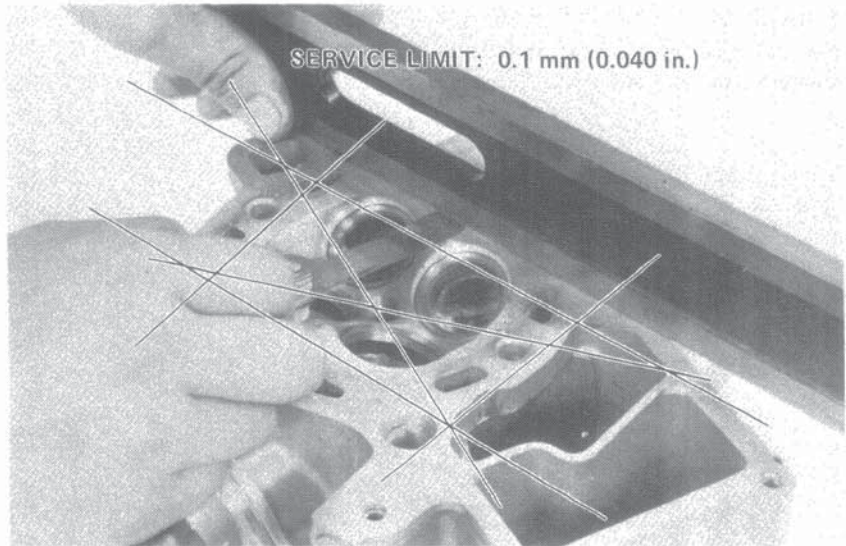

### • VALVE SPRING INSPECTION

Measure the free length of the inner and outer valve springs.

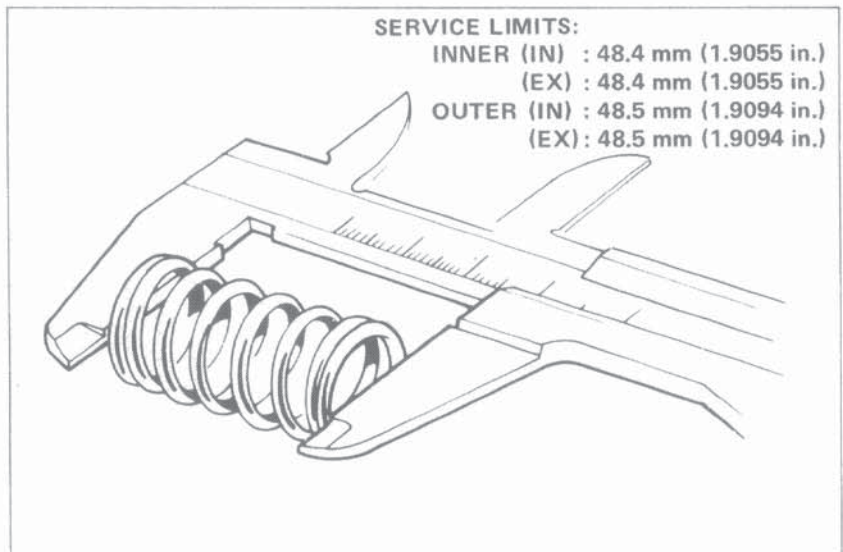





**CYLINDER HEAD/VALVE**

● **VALVE INSPECTION**

Clean the valves and inspect for trueness, burring, scoring, or abnormal stem end wear.

Check the valve movement in the guide.

Measure and record each valve stem O.D.

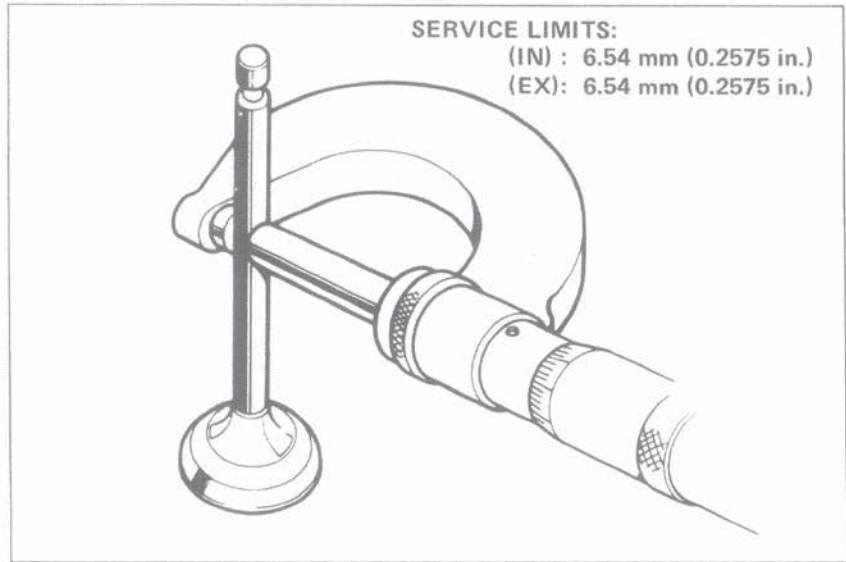

● **VALVE GUIDE INSPECTION**

Ream the guides to remove any carbon build-up before checking clearance.

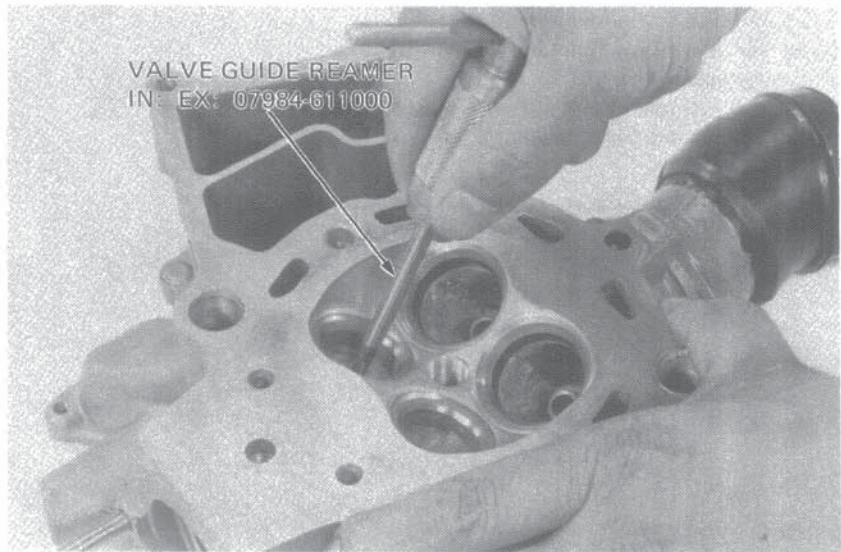

● **STEM-TO-GUIDE CLEARANCE INSPECTION**

Measure and record each valve guide I.D. using a ball gauge or inside micrometer.

Calculate the stem to guide clearance.

**SERVICE LIMITS:** (IN) : 0.10 mm (0.040 in.)  
(EX) : 0.10 mm (0.040 in.)

**NOTE**

If the stem to guide clearance exceeds the service limit, determine if a new guide with standard dimensions would bring the clearance within tolerance.  
If so, replace guides as necessary and ream to fit.

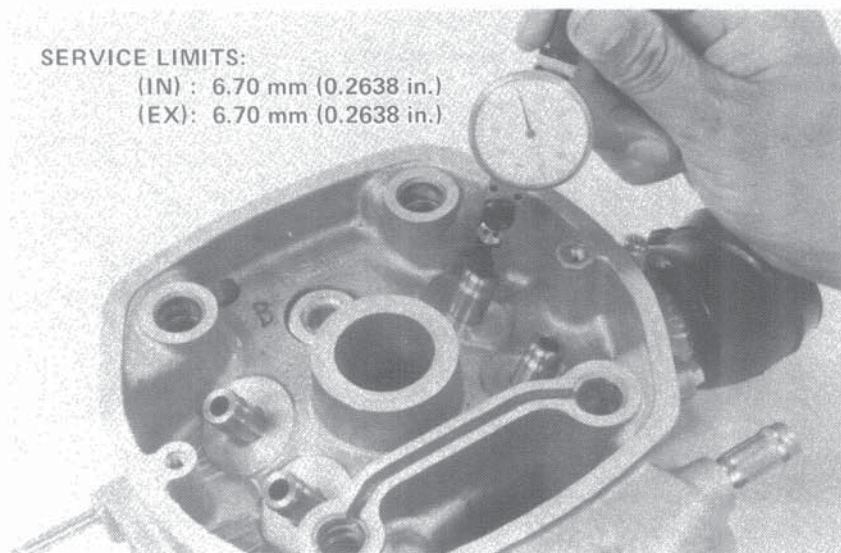





### VALVE GUIDE REPLACEMENT

If the stem-to-guide clearance still exceeds the service limits with new guides, replace the valves and guides.

#### NOTE

Do not damage the cylinder head when replacing valve guides.

Support the cylinder head and drive out the guide from the valve port.

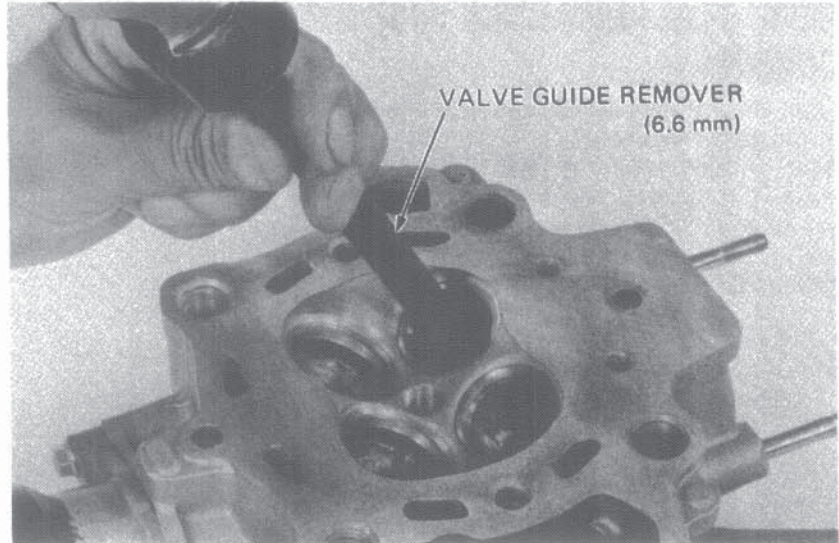

Place the ATTACHMENT on the VALVE GUIDE REMOVER. Drive the guides into place from the top of the head.

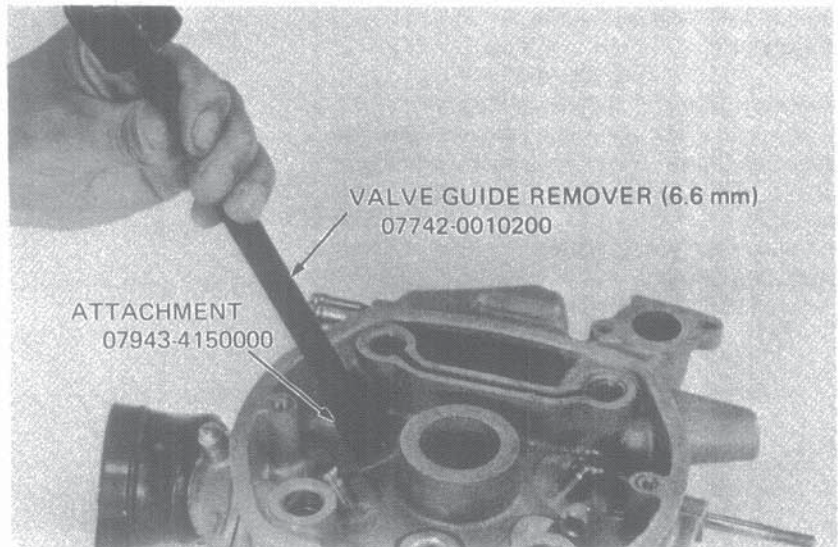

Ream the new valve guides after installation.

#### NOTE

- Use cutting oil on the reamer during this operation.
- It is important that the reamer be rotated when it is inserted or removed.
- Clean the head thoroughly of any particles.

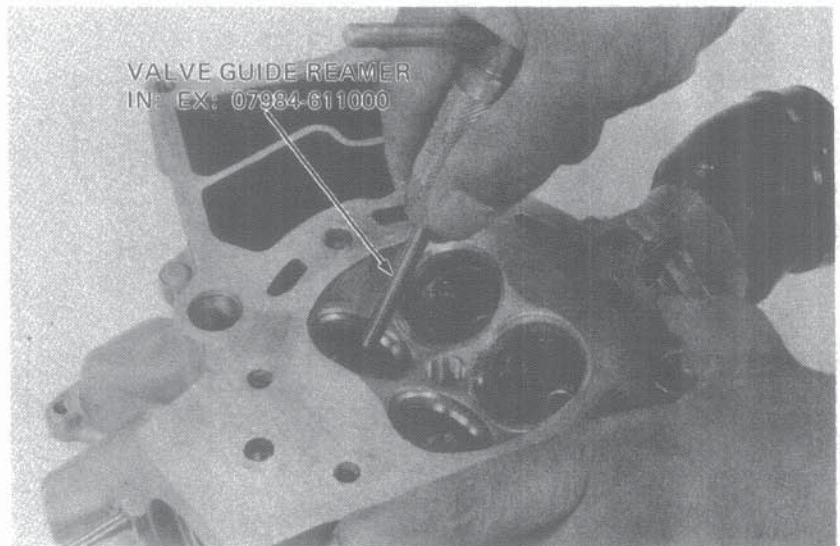





## VALVE SEAT INSPECTION AND GRINDING

Clean all intake and exhaust valves thoroughly to remove carbon deposits.

Apply a light coating of valve lapping compound to each valve face. Lap each valve and seat using a rubber hose or other hand-lapping tool.

Remove the valve and inspect the face.

### NOTE

The valves cannot be ground. If the valve face is rough, worn unevenly, or contacts the seat improperly, the valve must be replaced.

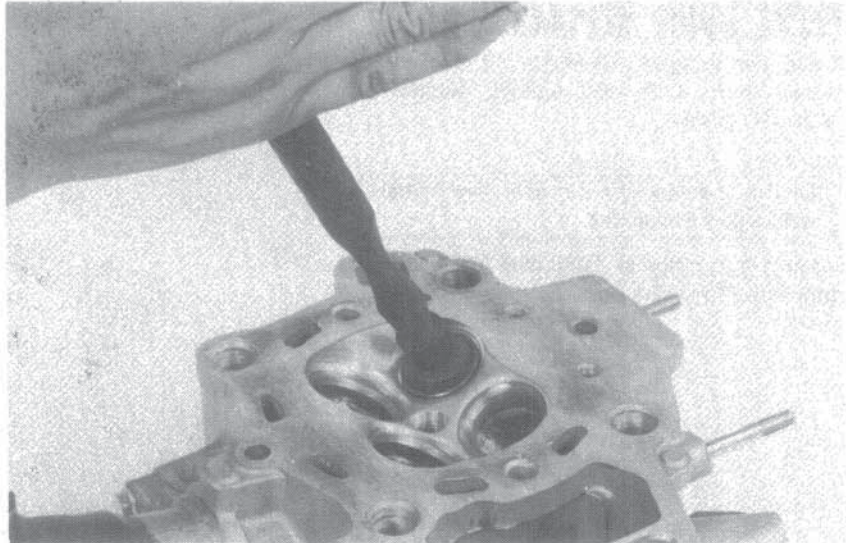

Inspect each valve seat width.

**STANDARD** : 1.1 – 1.3 mm  
(0.04–0.05 in.)

**SERVICE LIMIT** : 2.0 mm (0.08 in.)

If the seat is too wide, too narrow or has low spots, the seat must be ground. (A power grinder is recommended for good valve sealing.)

An even matt finish around the seat indicates good valve contact.

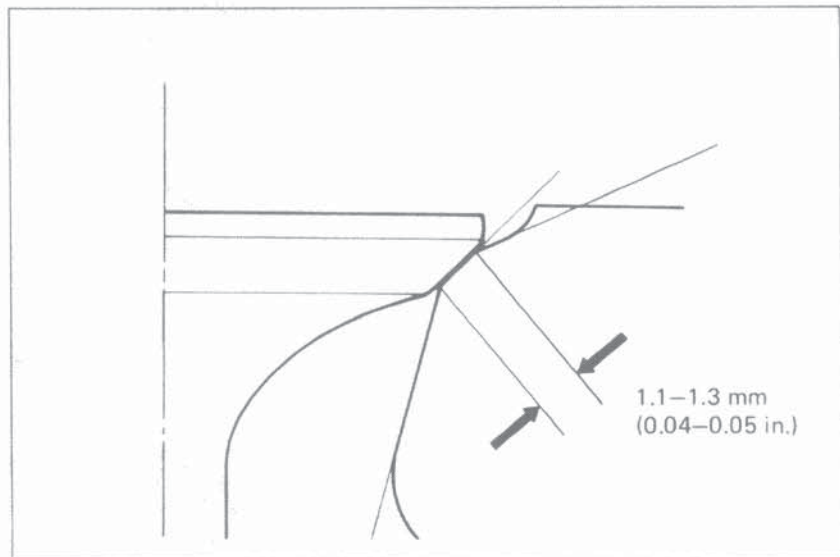

### NOTE

- Follow the refacer manufacturer's operating instructions.
  - Inspect each cutting stone for cracks. Reface the cutting stone to the correct angle.
- Each time a stone is removed and reinstalled on the grinder, it must be refaced on a dressing stand.

### GRINDING ANGLES

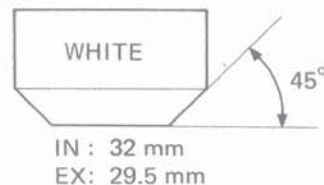
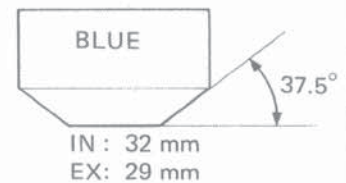
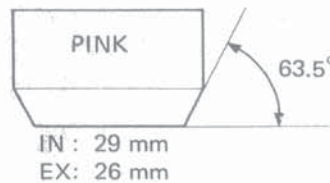





Insert the pilot bar into the valve guide firmly, and lubricate it lightly with thin oil.

**WARNING**

*Prevent eye injuries, wear adequate eye protection when using a valve seat grinder.*

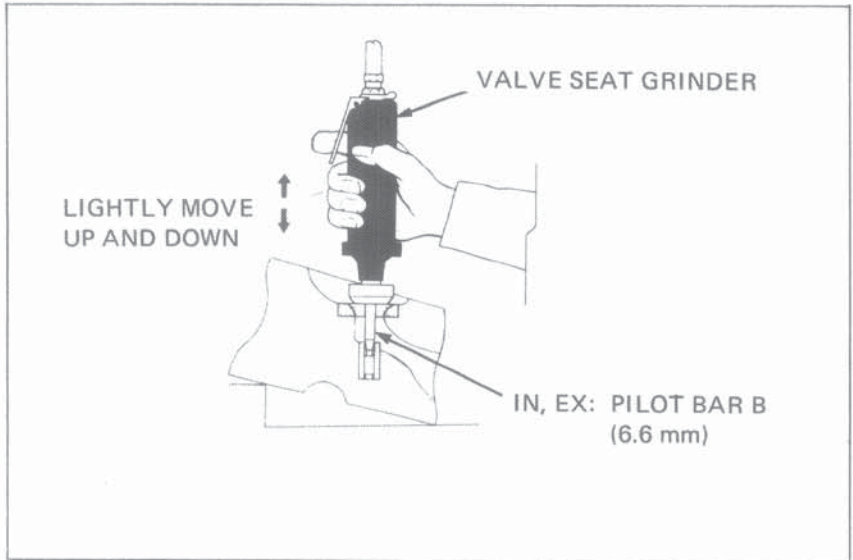

Using a 37.5 degree stone, remove 1/4 of the existing valve seat material. Remove the grinder and inspect the area of the valve seat you have removed.

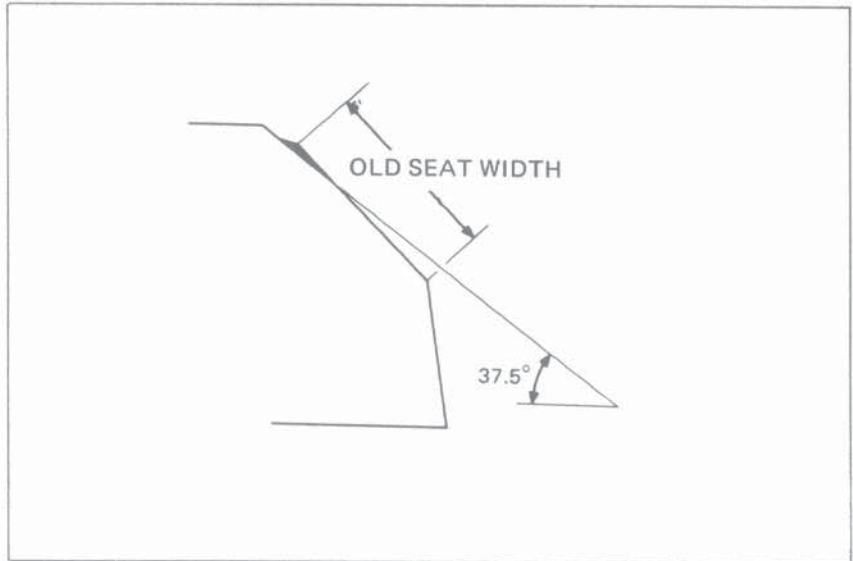

Use a 63.5 degree stone and remove the bottom 1/4 of the old seat. Remove the grinder and inspect the area you have just removed.

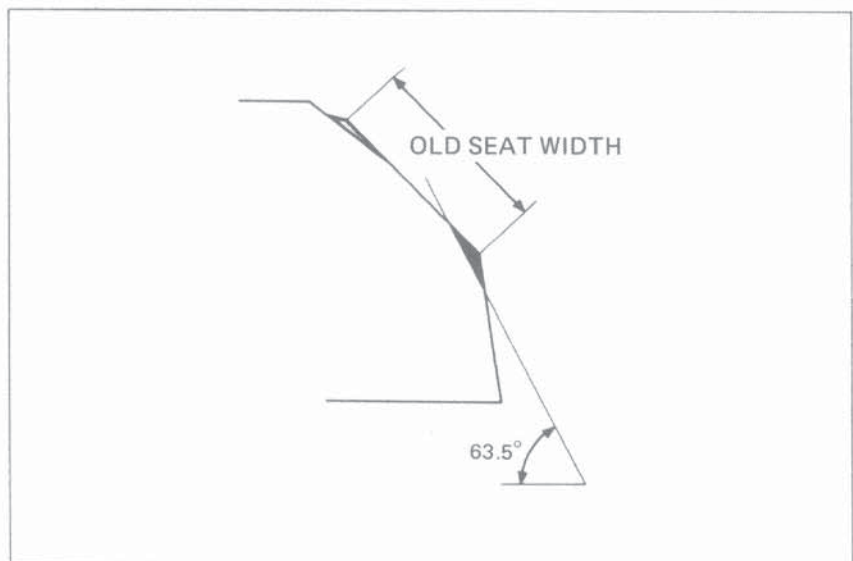



**CYLINDER HEAD/VALVE**

Install a 45 degree finish cut stone and cut the seat to the proper width.

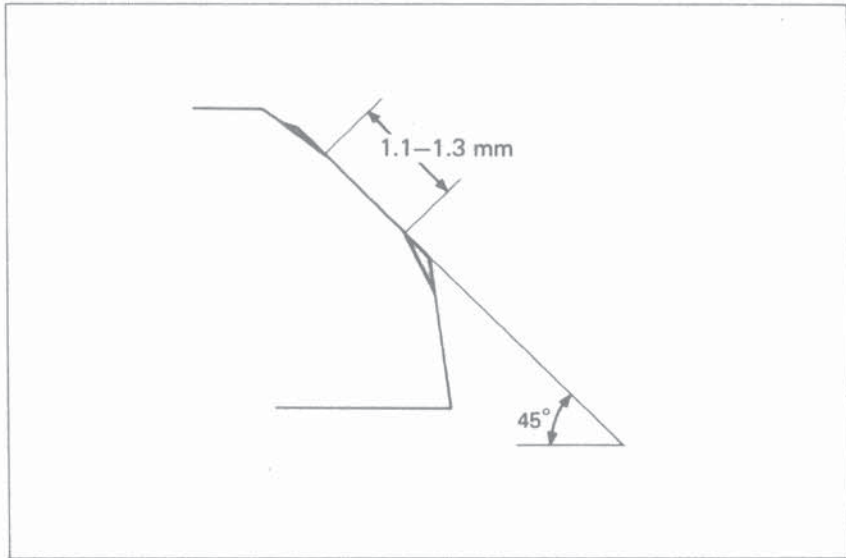

If the contact area on the valve face is too low, the seat must be raised, using a 63.5 degree stone. Refinish the seat to 1.1-1.3 mm width using a 45 degree finishing stone.

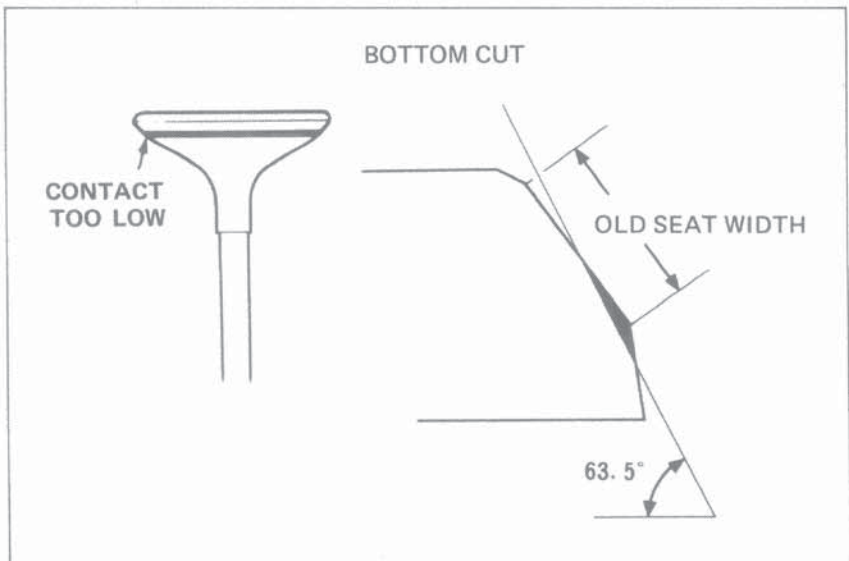

If the contact area on the face of the valve is too high, the seat must be lowered, using a 37.5 degree cutting stone.

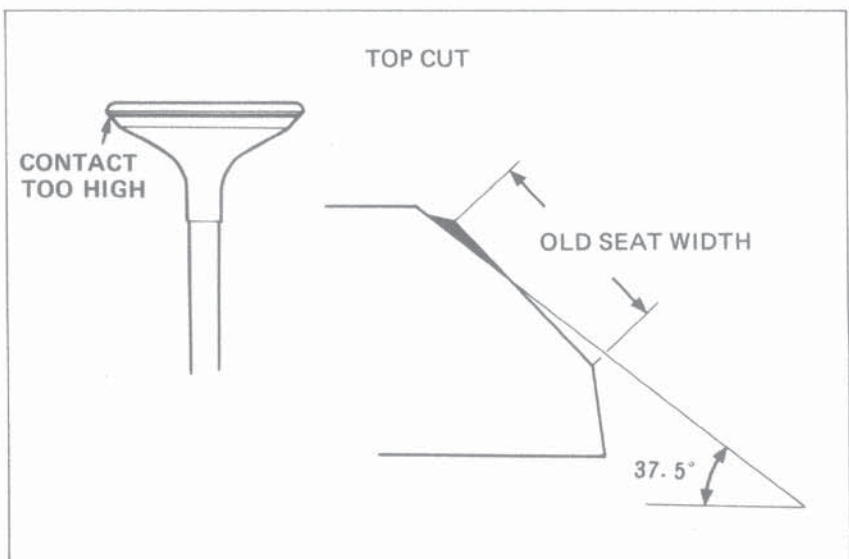





After cutting the seat, apply lapping compound to valve face, and lap the valve.

After lapping, wash all residual compound off the cylinder head and valve.

**NOTE**

- Lap the valve using light pressure.
- Do not allow lapping compound to enter the guides.

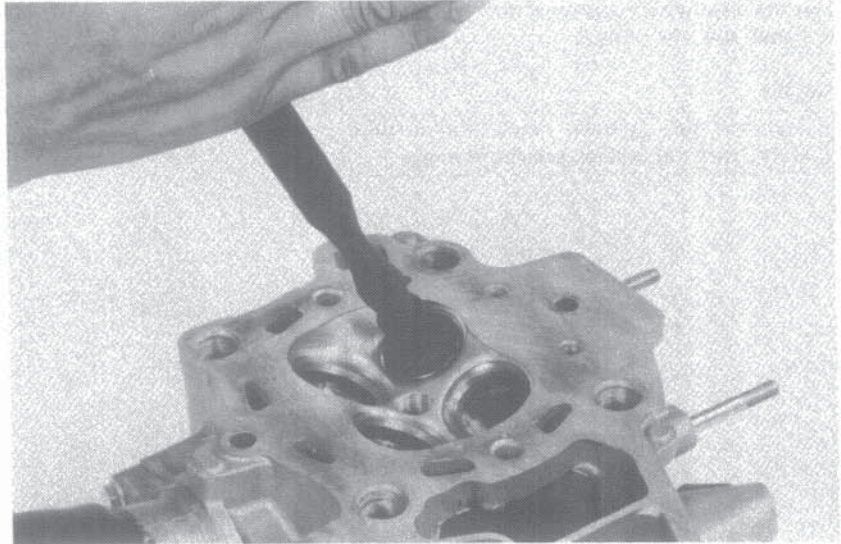

**CYLINDER HEAD ASSEMBLY**

Install the valve stem seals and spring seats. Lubricate the valve stems with oil, and insert the valves into the guides. Install the valve springs and retainers.

**NOTE**

- Install the valve springs with the tightly wound coils facing the head.
- Replace the stem seals with new ones whenever disassembled.

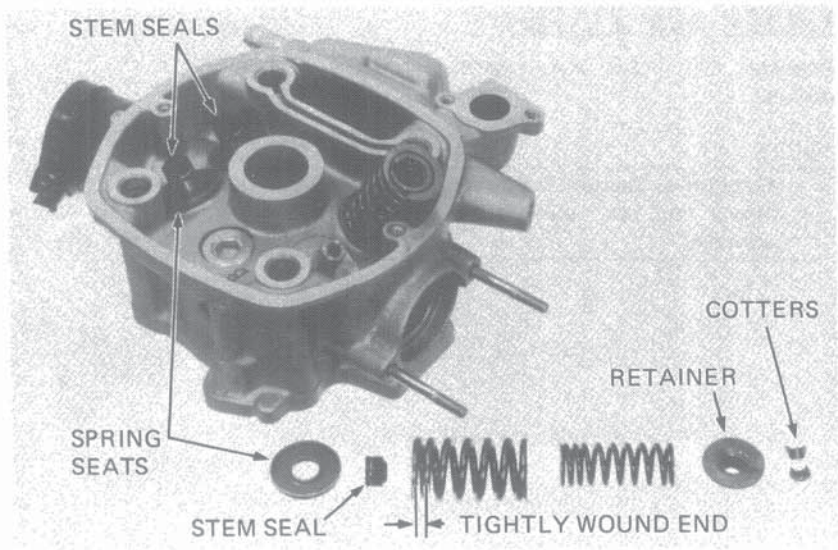

Install the valve cotters.

**CAUTION**

*To prevent loss of tension, do not compress the valve spring more than necessary.*

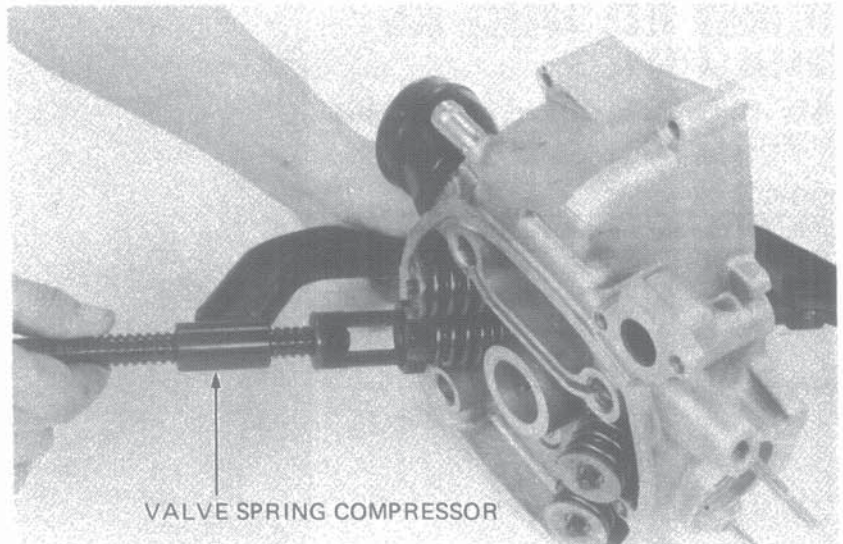





**CYLINDER HEAD/VALVE**

Tap the valve stems gently with a soft hammer to firmly seat the cotters.

**NOTE**

Support the cylinder head above the work bench surface to prevent damage.

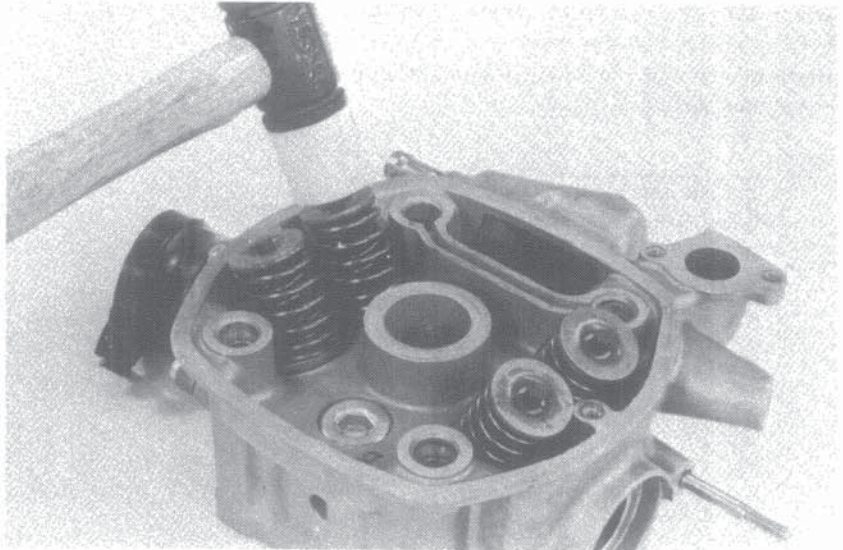

**ROCKER ARM ASSEMBLY**

Assemble the rocker arms, shafts and wave washers.

**NOTE**

- Note the rocker arm shaft direction.
- Apply oil to each shaft before assembly.

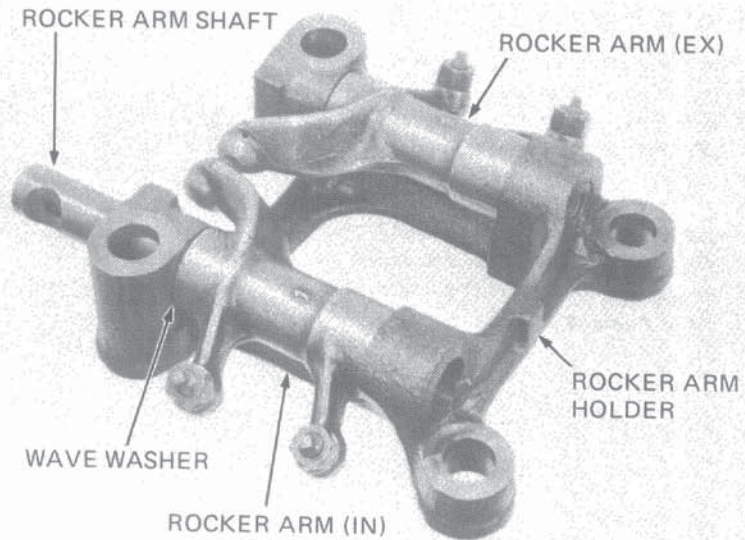

**CYLINDER HEAD/ROCKER ARM INSTALLATION**

Clean the cylinder surfaces of any gasket material.

**NOTE**

Do not damage the gasket surfaces.

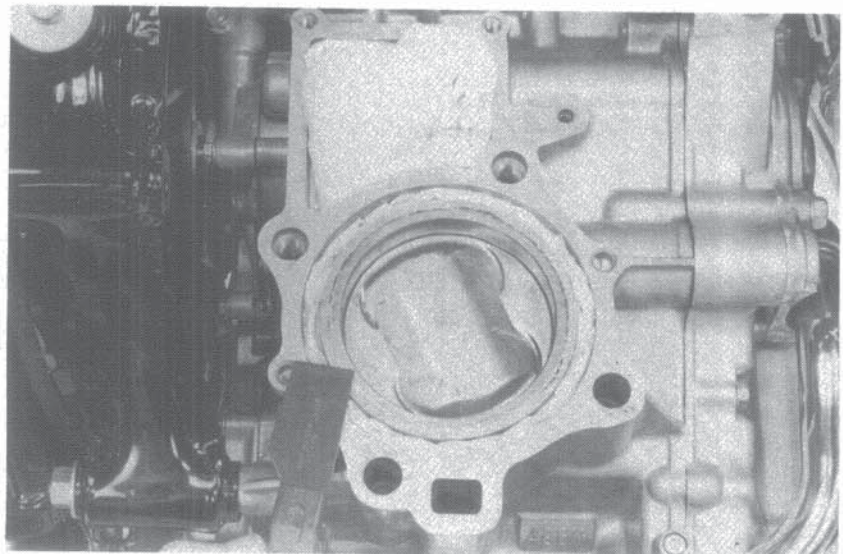





Install the O-rings and dowel pins.  
Coat the cylinder and head surfaces with liquid sealer, and install the head gasket. Make sure that the oil orifices are not covered by gasket.

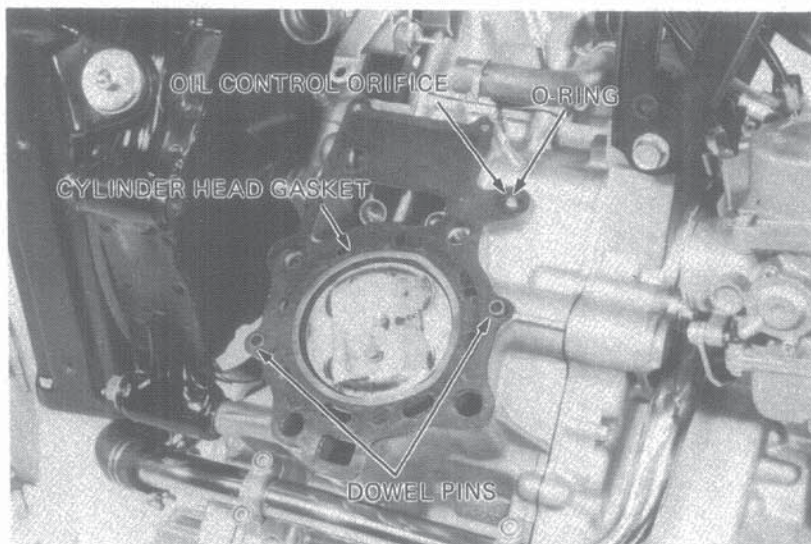

Install the cylinder drain bolts.  
Remove the timing inspection cap.  
Check the timing mark to be certain that the cylinder to be serviced is at TDC on the compression stroke.

### NOTE

- Align the index mark with the "TR" mark for the right cylinder.
- Align the index mark with the "TL" mark for the left cylinder.

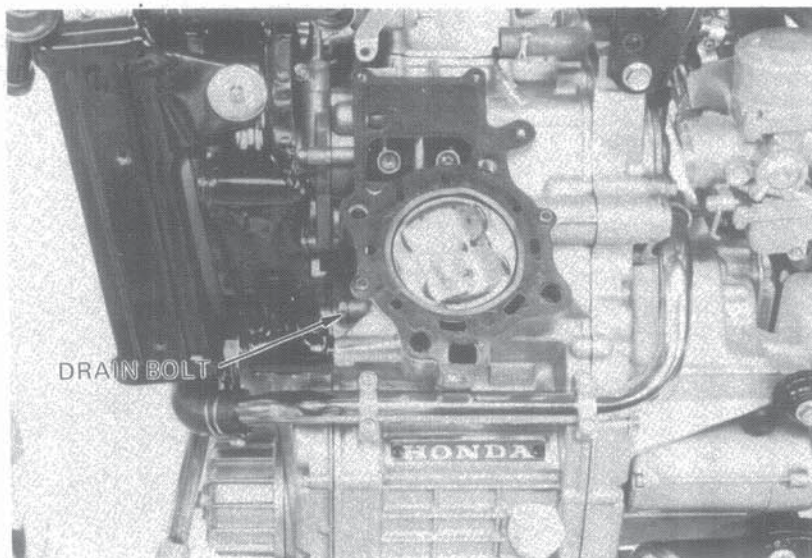

Install each cylinder head.  
Install the dowel pins.  
Insert the push rods into the rocker arm retainers.

### NOTE

- Apply molybdenum disulfide grease to the end of each push rod.

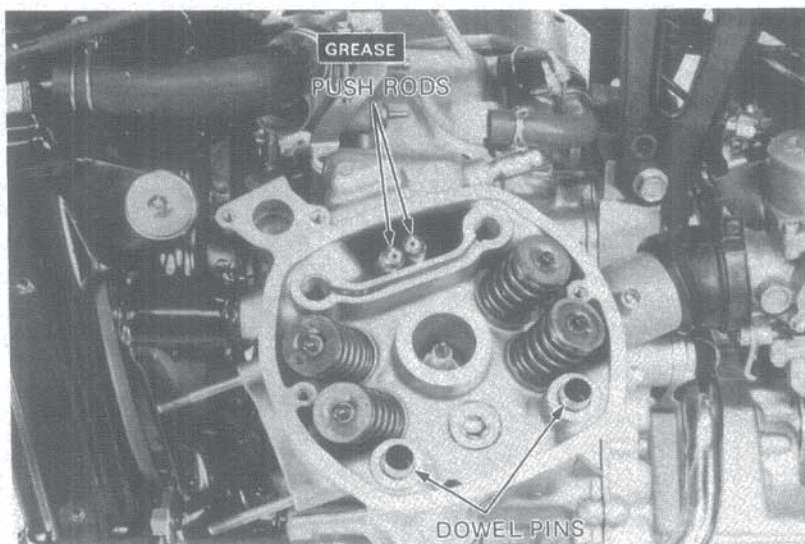





**CYLINDER HEAD/VALVE**

Loosen the valve adjusting screws.  
Install the rocker arm holder assembly, aligning the rocker arms with the push rods.

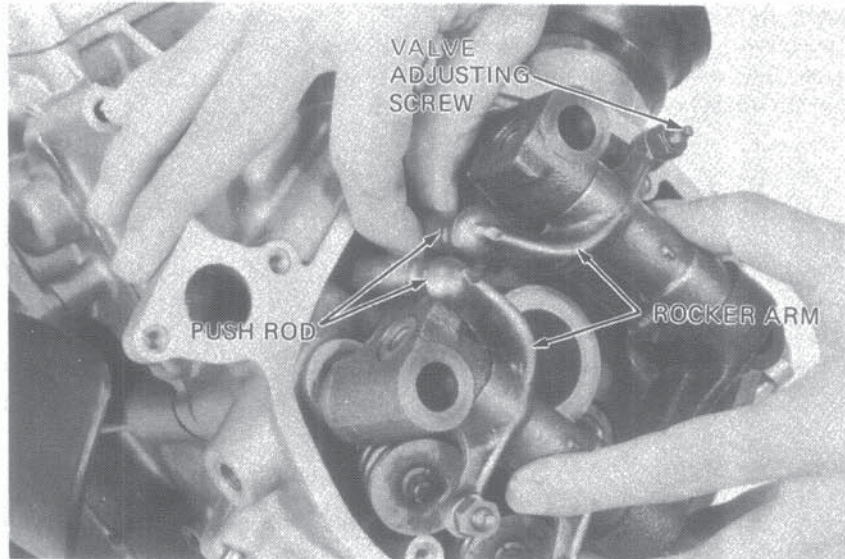

Torque the cylinder head bolts in the sequence shown.

**TORQUE: 5.0–5.5 kg-m (33–40 ft-lbs)**

**NOTE**

Tighten the bolts in 2–3 steps.

Install the water pipe joint.  
Install the thermostat bracket with 6 mm bolt.  
Install and torque the engine front hanger bolts.  
**TORQUE: 3.0–4.0 kg-m (22–29 ft-lbs)**  
Route the thermometer wire, oil pressure gauge wire and thermostat by-pass hose through the air spoiler and connect.

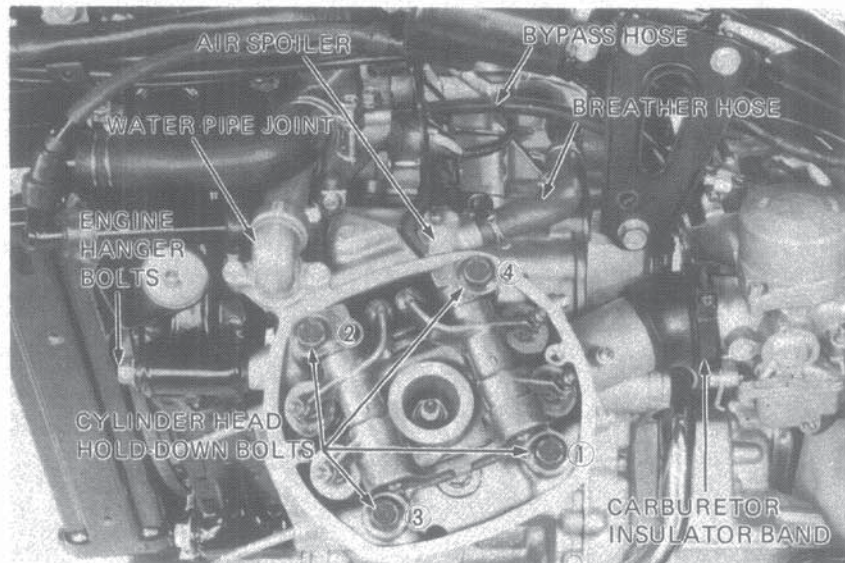

Tighten the air spoiler bolts.  
Tighten the carburetor band.  
Adjust the valve clearance (Page 3-4).  
Torque the radiator drain bolt.

**TORQUE: 0.15–0.30 kg-m**  
**(1.1–2.2 ft-lbs, 13–26 in-lbs)**

Connect the thermometer and oil pressure gauge wires.

Install the exhaust pipes.  
Fill the radiator with coolant.  
Check for oil, water and gas leaks.  
Install the radiator cover.

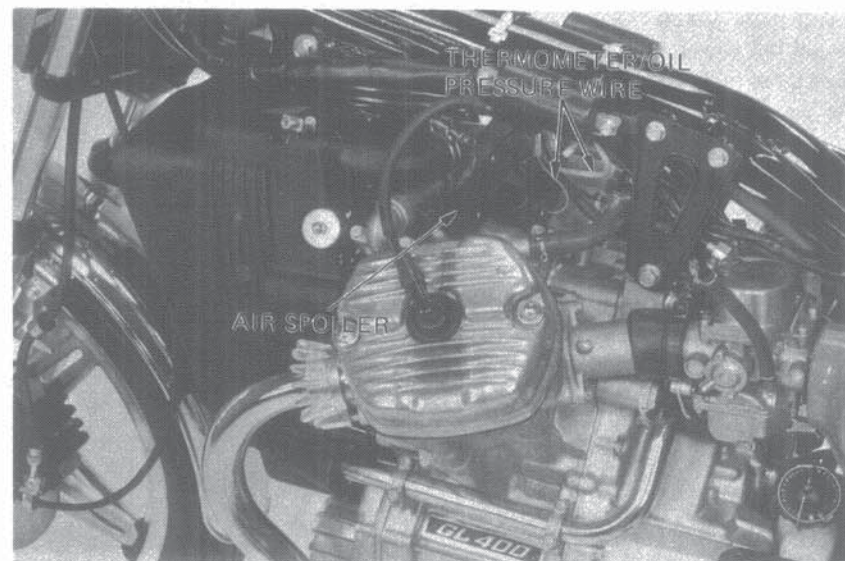





CLUTCH/OIL PUMP

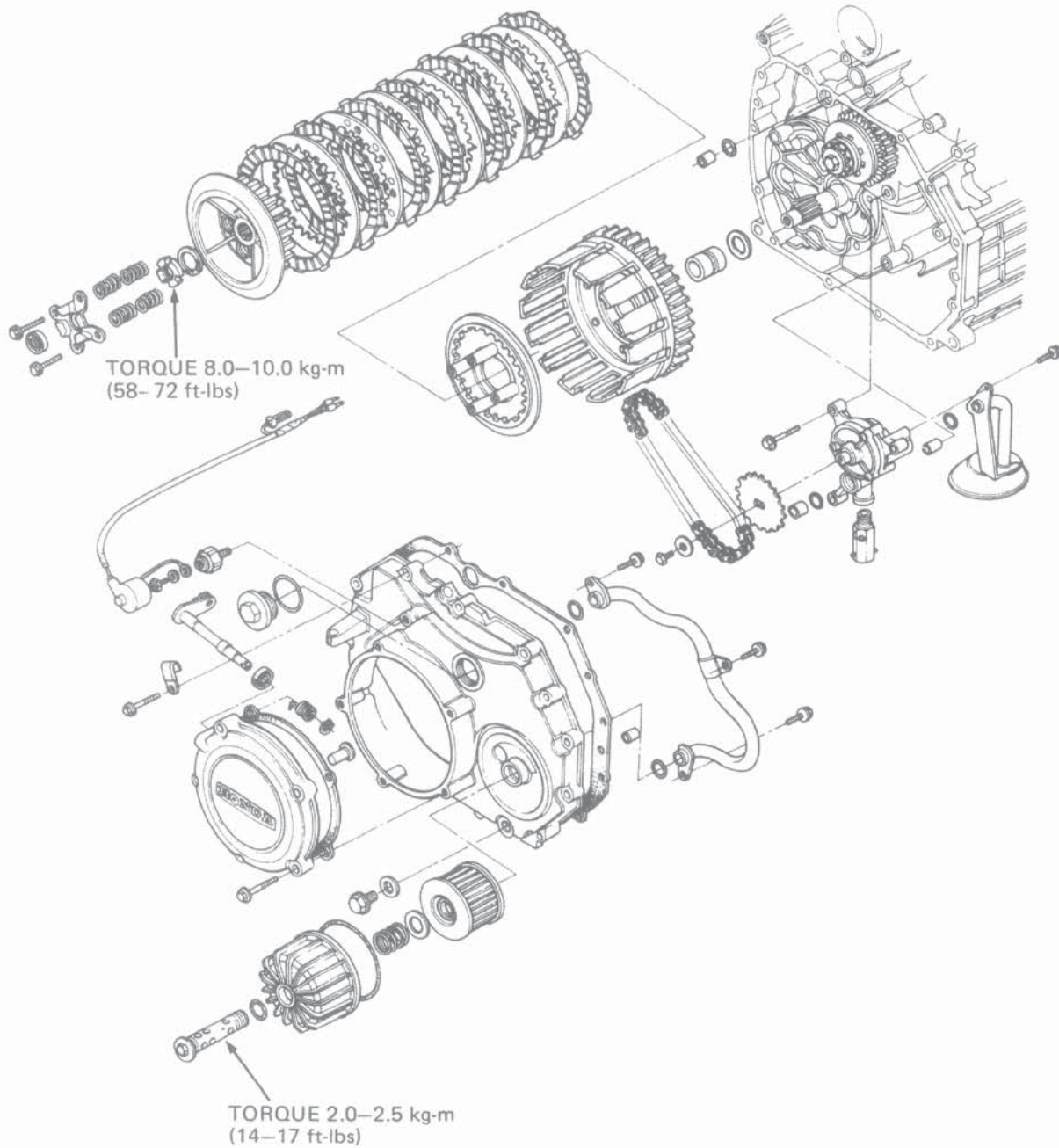



# 7. CLUTCH/OIL PUMP

SERVICE INFORMATION	7- 1
TROUBLESHOOTING	7- 1
CLUTCH REMOVAL	7- 2
CLUTCH INSTALLATION	7- 5
OIL PUMP REMOVAL	7- 8
OIL PUMP INSTALLATION	7-11

## SERVICE INFORMATION

### • WORKING PRACTICE

Clutch discs, plates "A" and "B", clutch center, and clutch plates can be serviced by removing the clutch cover. To service the oil pump, it is necessary to remove the radiator and transmission cover. All these operations can be accomplished with the engine in the frame.

### • SPECIAL TOOLS

Special tool	
CLUTCH CENTER HOLDER	07923-4150000
Common tools	
LOCK NUT SOCKET WRENCH (26 x 29 mm)	07716-0020201
EXTENSION HANDLE	07716-0020500

### • SPECIFICATIONS

		Standard	Service Limit	
Clutch	Lever free play (at lever end)	10-20 mm (3/8-3/4 in.)	-	
	Clutch spring	Free length	33.90 mm (1.3346 in.)	32.5 mm (1.2795 in.)
		Tension	19.7-22.3 kg/23.5 mm (43.4-49.2 lbs/0.9252 in.)	18.0 kg/23.5 mm (39.7 lbs/0.9252 in.)
	Disc thickness	A	2.7 mm (0.1062 in.)	2.3 mm (0.0905 in.)
		B	3.5 mm (0.1378 in.)	3.1 mm (0.1220 in.)
	Plate warpage	A	-	0.20 mm (0.008 in.)
		B	-	0.20 mm (0.008 in.)
	Clutch outer I.D.		33.000-33.016 mm (1.2992-1.2998 in.)	33.07 mm (1.3019 in.)
Outer guide O.D.		32.950-32.975 mm (1.2972-1.2982 in.)	32.90 mm (1.2952 in.)	
Oil pump	Inner-to-outer rotor clearance	-	0.10 mm (0.004 in.)	
	Outer rotor-to-body clearance	-	0.35 mm (0.0138 in.)	
	Rotor-to-body clearance	-	0.10 mm (0.004 in.)	
Oil pressure relief valve Relief pressure		5.0-6.0 kg/cm <sup>2</sup> (71.1-85.3 psi.)	-	

## TROUBLESHOOTING

### Oil Pump

- Refer to page 2-1 for oil pump troubleshooting.

### Clutch

- Faulty clutch operation can usually be corrected by adjusting the free play.

### Clutch Slips When Accelerating

- No free play
- Discs worn
- Springs weak

### Clutch Will Not Disengage

- Too much free play
  - Plates warped
- ### Clutch Chatters or Rattles
- Worn clutch outer and disc splines
- ### Motorcycle Creeps with Clutch Disengaged
- Too much free play
  - Plates warped
- ### Excessive Lever Pressure
- Clutch cable linked, damaged or dirty
  - Lifter mechanism damaged
- ### Clutch Operation Feels Rough
- Outer drum slots rough
  - Disc plate wave spring weak or damaged





## CLUTCH REMOVAL

Drain the oil from engine.  
Disconnect the clutch cable at the lower adjuster.  
Remove the clutch cover.

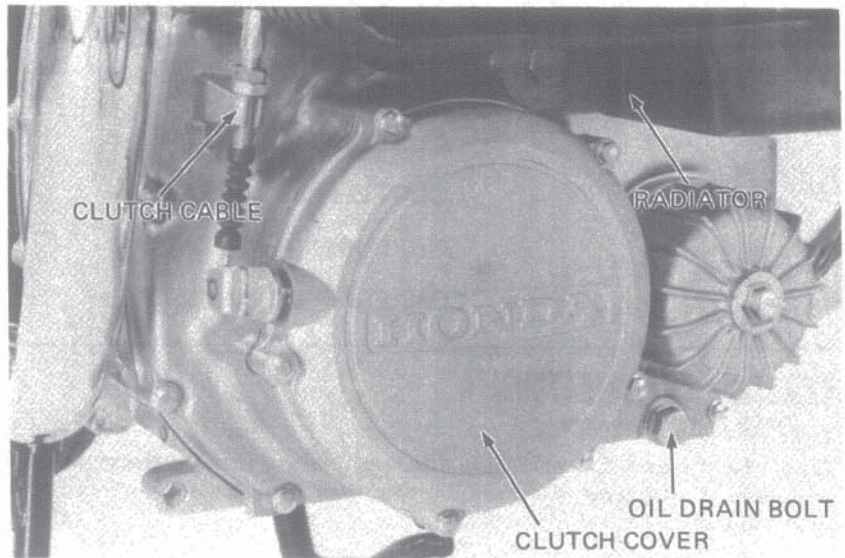

### • CLUTCH LIFTER REMOVAL

Remove the lifter piece, circlip, spring, clutch lever and O-ring.

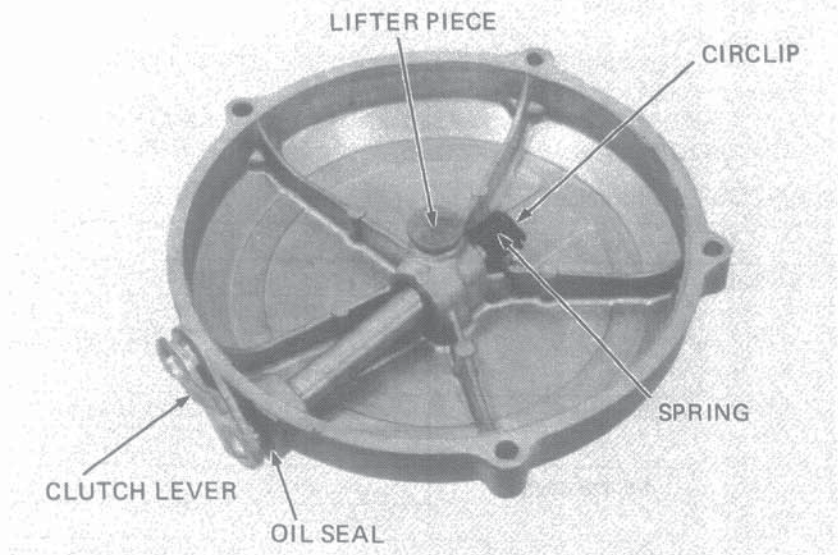

### • CLUTCH LIFTER PLATE REMOVAL

Remove the bolts, springs and lifter plate.

#### NOTE

Loosen the bolts in an X pattern in two or more steps.

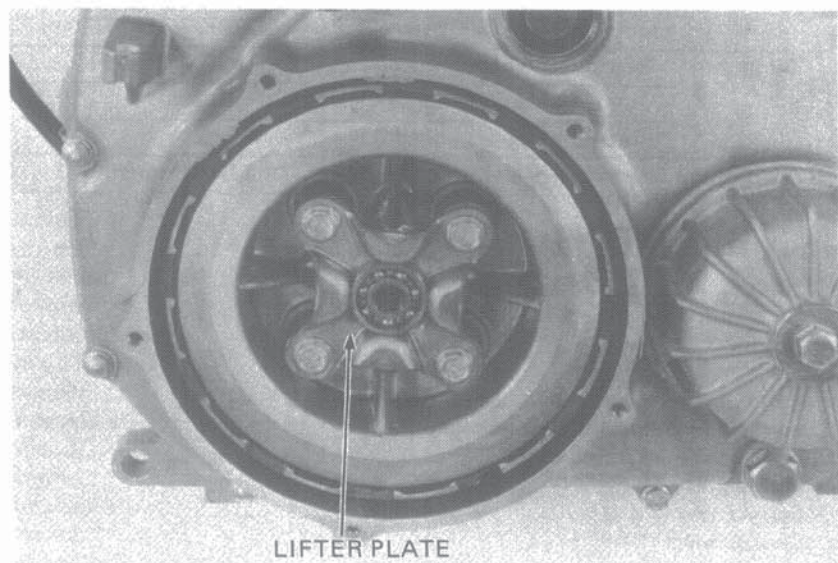





• **CLUTCH REMOVAL**

Attach the CLUTCH CENTER HOLDER on to the pressure plate boss with four, 6 x 35 mm bolts.

**NOTE**

Tighten the bolts finger tight.

Remove the lock nut and lock washers.

**CAUTION**

*Damage to the pressure plate will occur, if the clutch center holder is not attached with 4 bolts.*

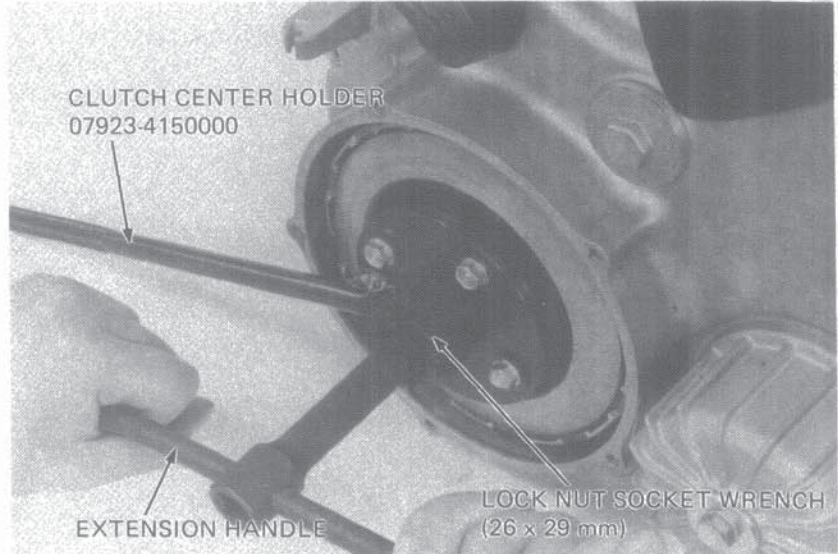

Remove the pressure plate, discs "A" and "B", disc plate, and clutch center as a unit.

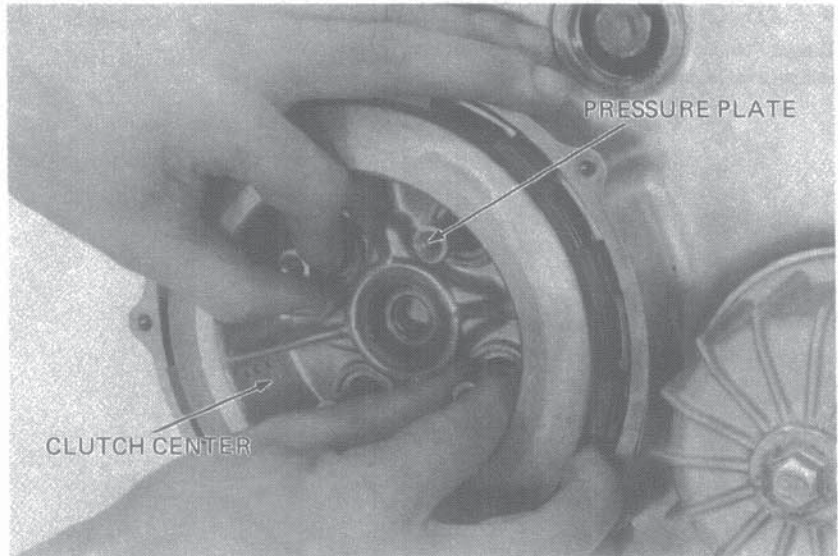

Remove the clutch outer.  
Remove the clutch outer guide and thrust washer.

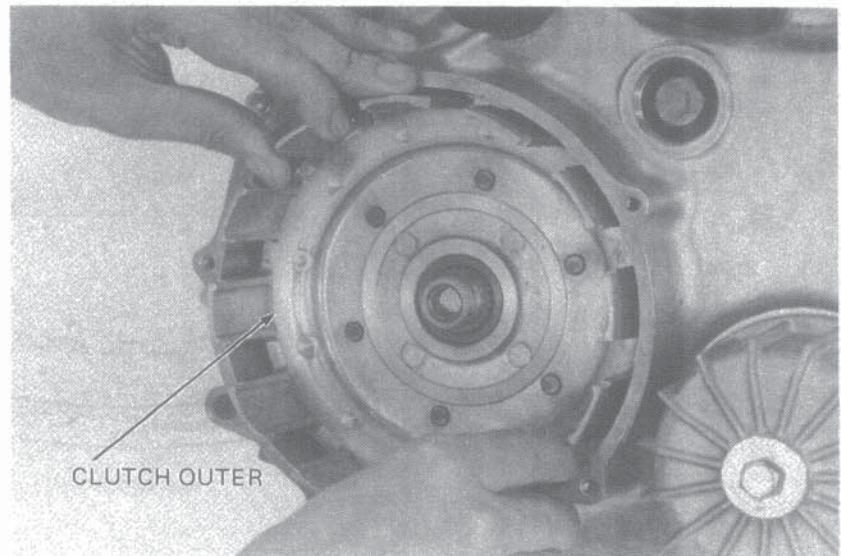





**CLUTCH/OIL PUMP**

• **CLUTCH DISC INSPECTION**

Replace the clutch discs if they show signs of scoring or discoloration.  
Measure the disc thickness.

**SERVICE LIMITS:**

- Disc A: 2.30 mm (0.0905 in.)
- Disc B: 3.10 mm (0.1220 in.)

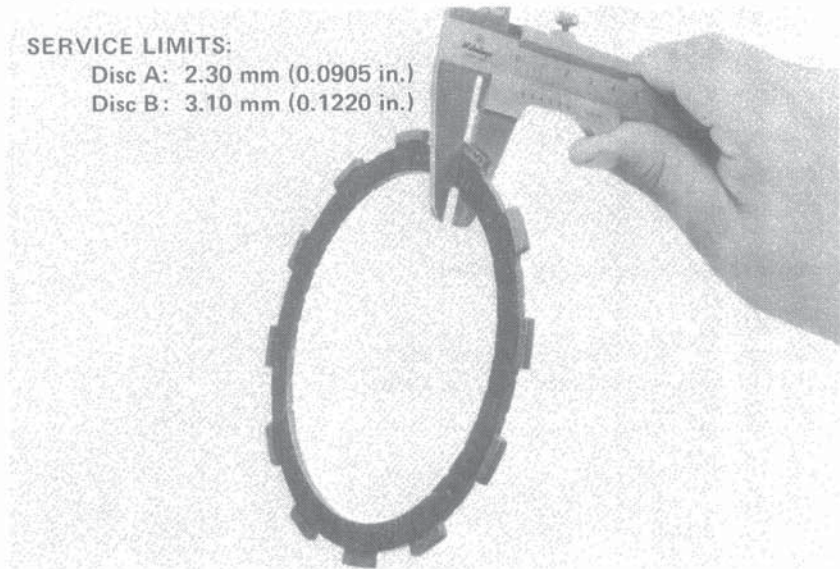

• **CLUTCH PLATE INSPECTION**

Check for plate warpage on a surface plate, using a feeler gauge.

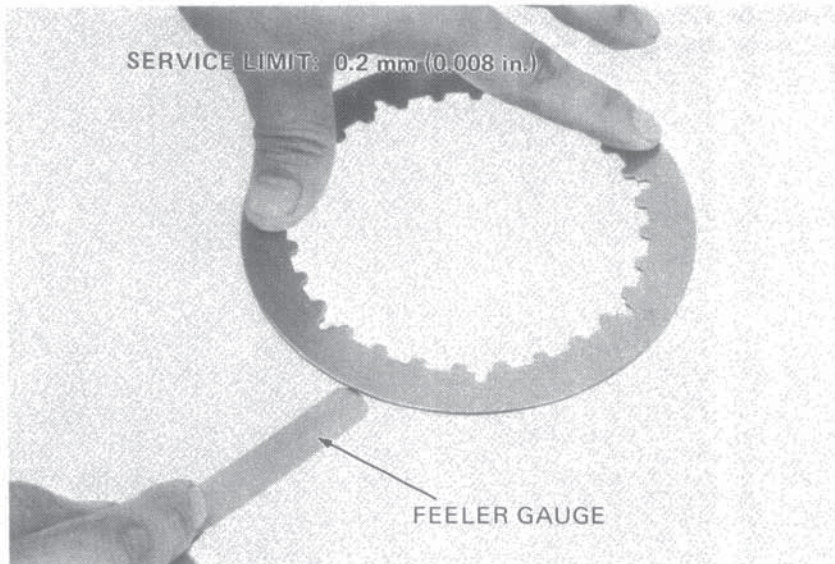

**SERVICE LIMIT: 0.2 mm (0.008 in.)**

• **CLUTCH PLATE B INSPECTION**

Check the wave spring for damage.

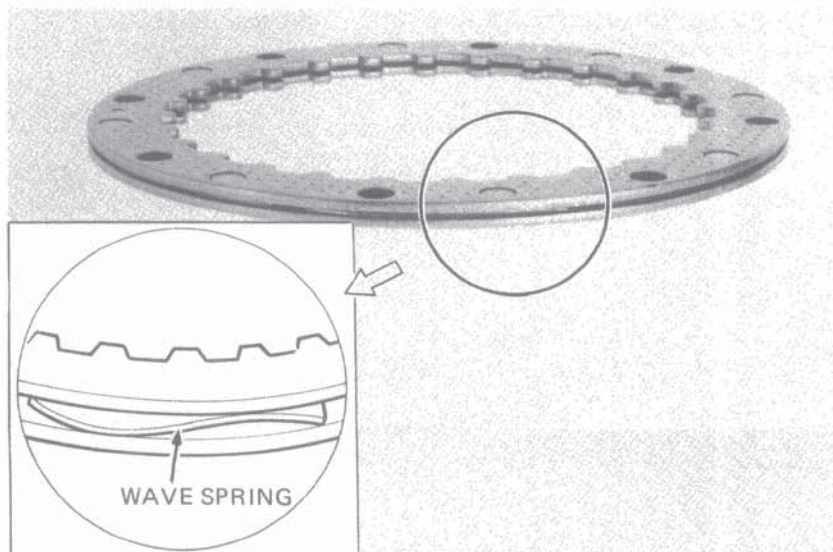



### • CLUTCH OUTER AND OUTER GUIDE INSPECTION

Check the slots in the outer drum for nicks, cuts or indentations made by the friction discs.

Measure the I.D. of the clutch outer and the O.D. of the outer guide.

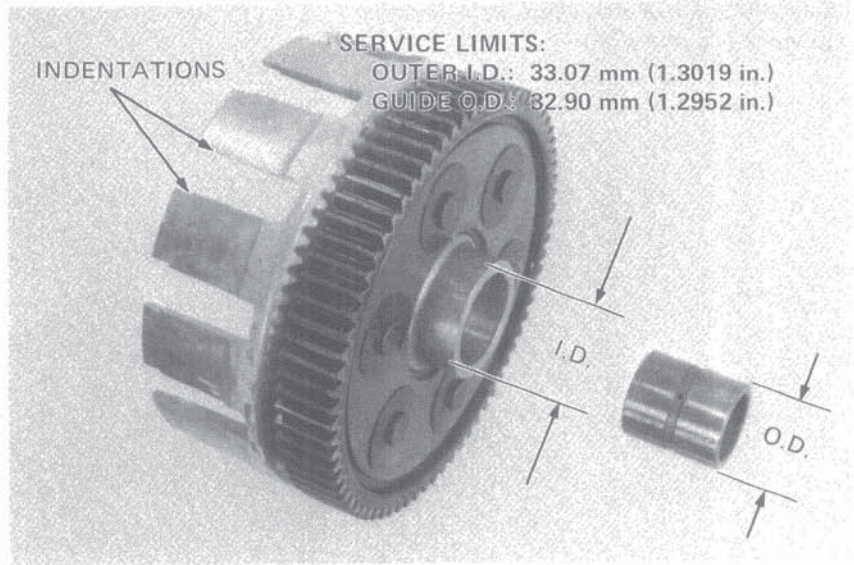

### • CLUTCH SPRING INSPECTION

Measure the spring free length.

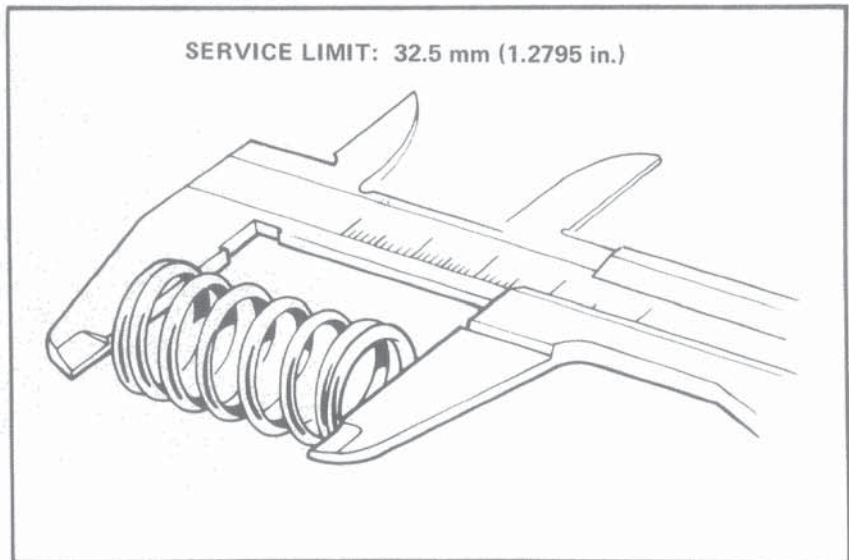

## CLUTCH INSTALLATION

Install the clutch plates and discs in the clutch outer as shown.

### NOTE

The disc on the pressure plate side is identified by the grooves in its lining.

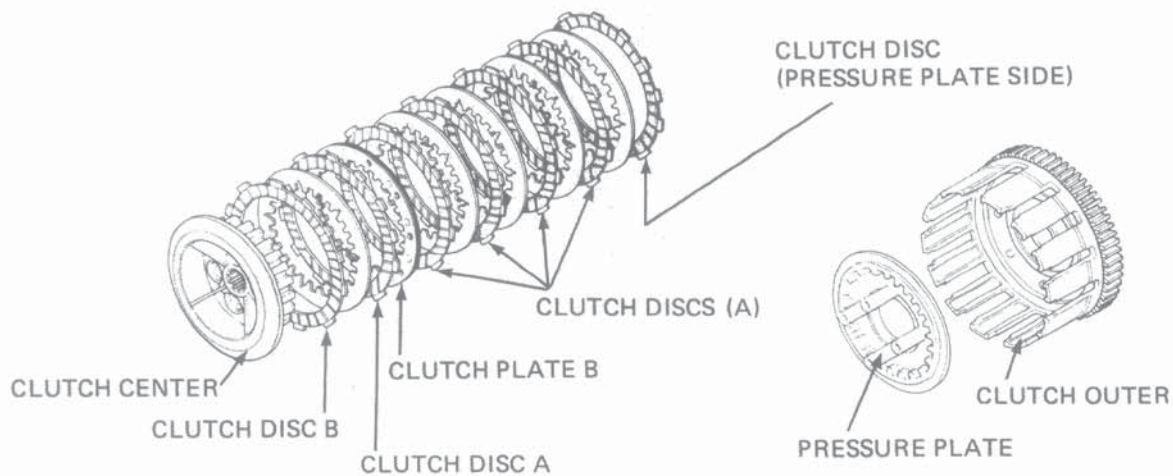





**CLUTCH/OIL PUMP**

Install the clutch center, aligning the splines by rotating the clutch center.

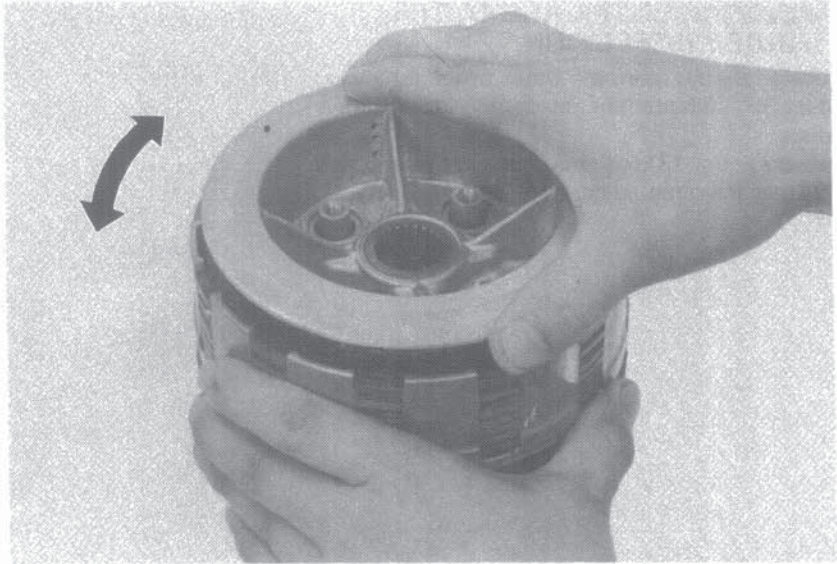

Install the thrust washer and outer guide on the main shaft.

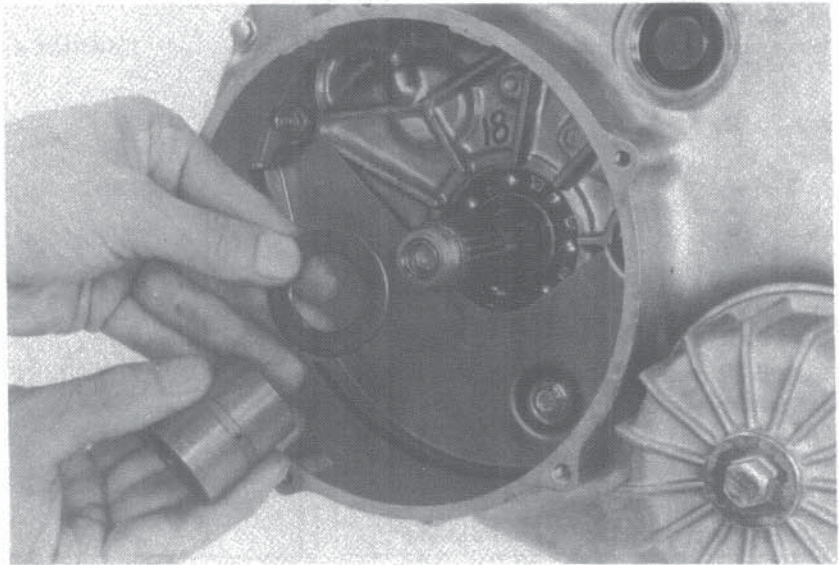

Install the clutch on the main shaft.  
Install the lock washer and lock nut.

**NOTE**

Be sure the washer and nut facing directions are correct.

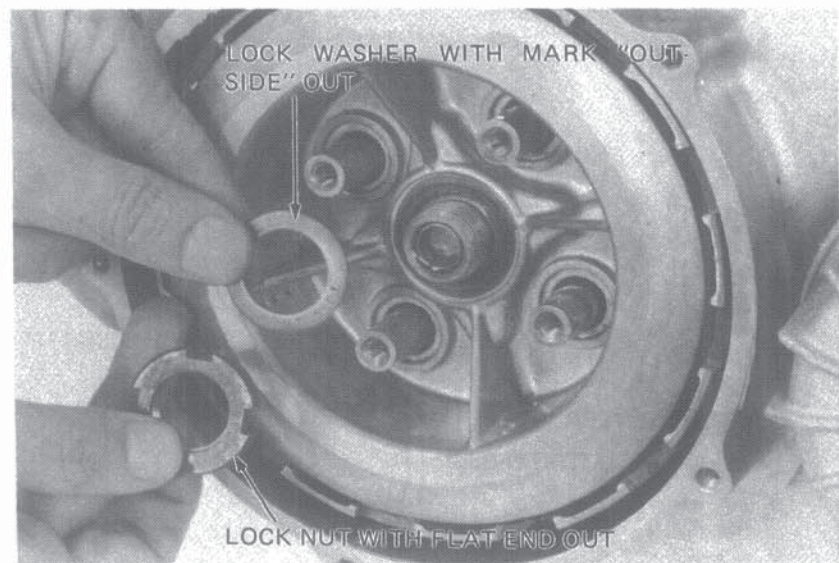





Attach the CLUTCH CENTER HOLDER to the pressure plate boss to prevent it from turning. Torque the lock nut.

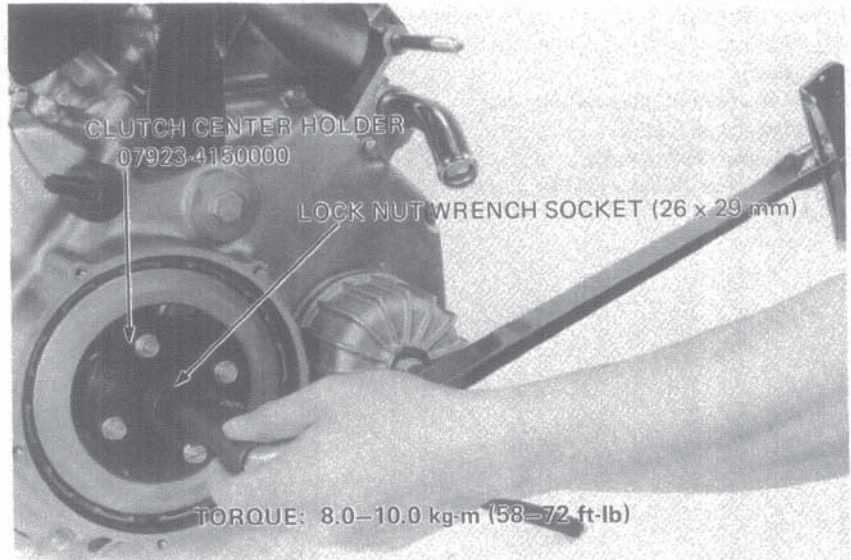

Install the clutch springs, lifter plate, and lifter plate bolts.

**NOTE**

Tighten the bolts evenly 2-3 steps using a criss cross pattern.

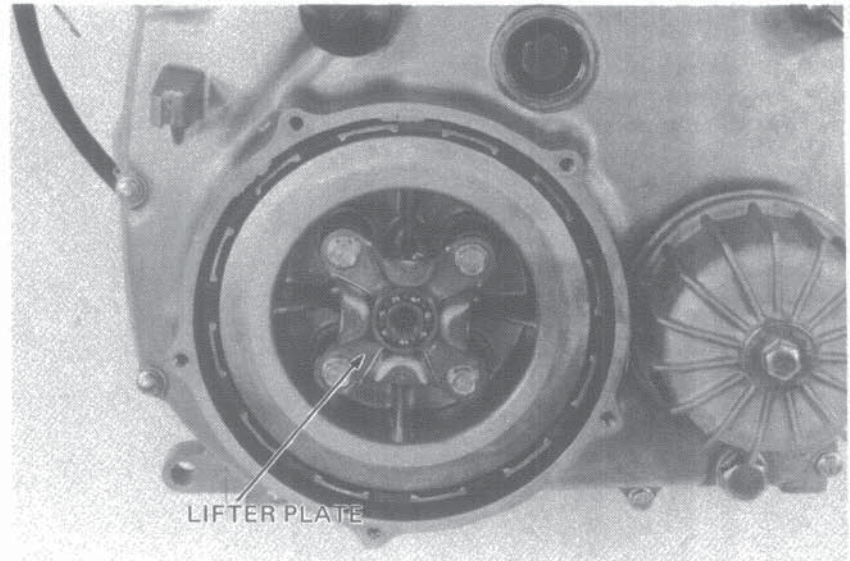

Install the oil seal in the clutch cover.  
Install the clutch lever.  
Install the spring and circlip.

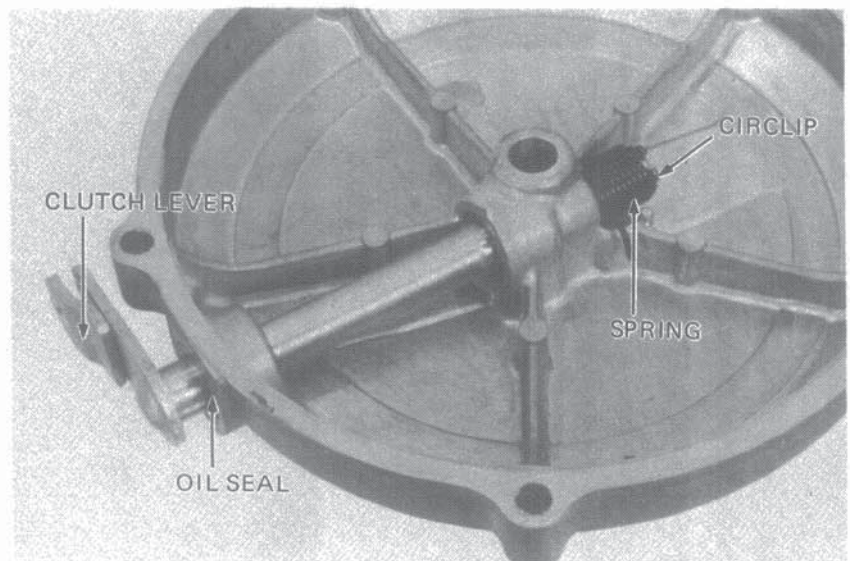





**CLUTCH/OIL PUMP**

Rotate the clutch lever to align hole in the lever with the hole in the clutch cover and insert the lifter piece.  
Install the clutch cover gasket.  
Install the clutch cover.  
Connect the clutch cable.  
Adjust the clutch (Page 3-13).

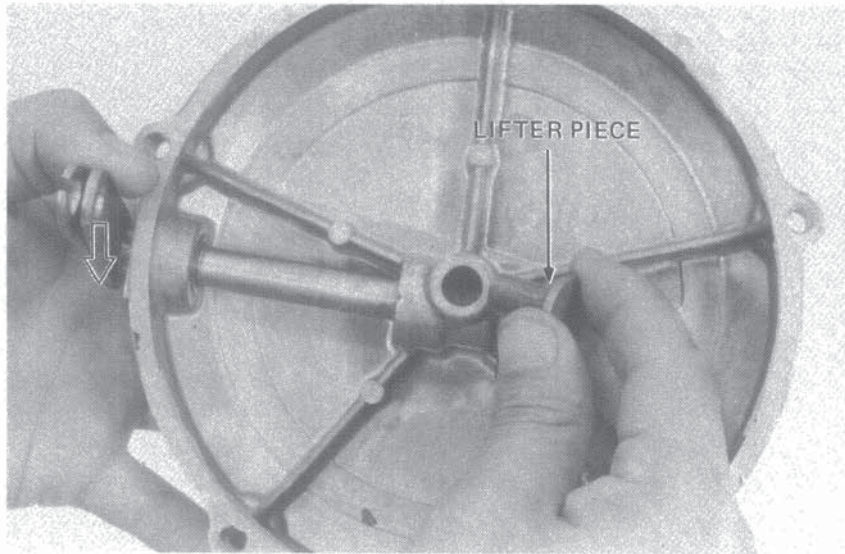

**OIL PUMP REMOVAL**

Drain the oil from the engine.  
Disconnect the oil pressure switch.  
Remove the transmission cover.

**NOTE**

When this operation is to be accomplished with the engine in the frame, remove the radiator and clutch cable at the lower adjuster.

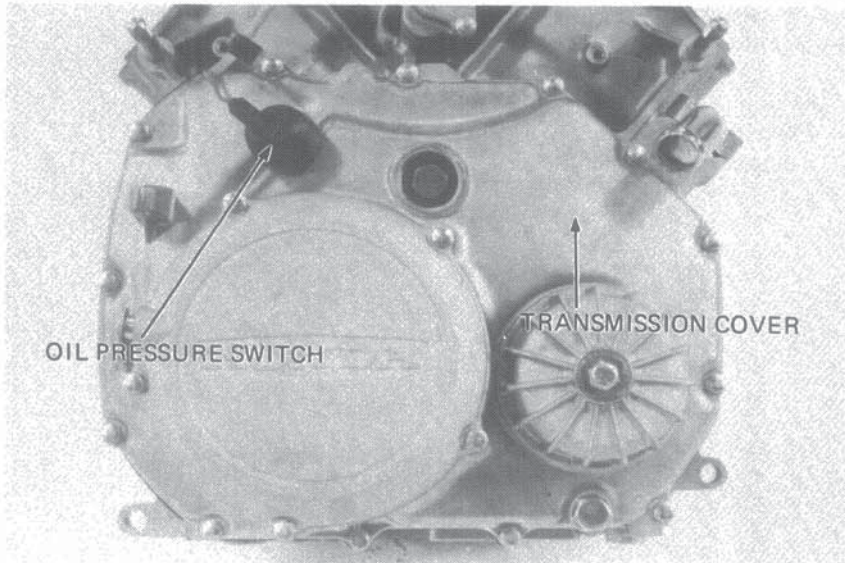

Remove the two, 6 mm bolts shown and the oil pump drive chain.

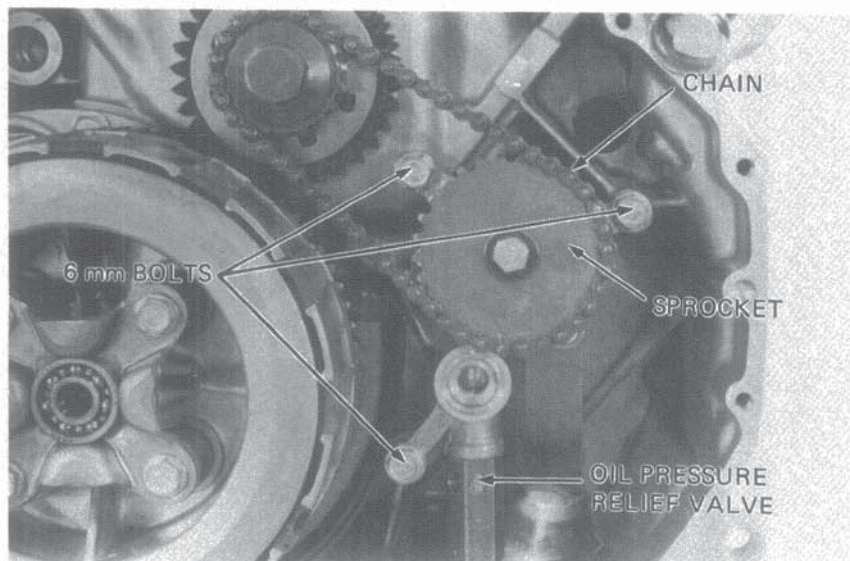





• **OIL PUMP DISASSEMBLY**

Remove the pressure relief valve and oil strainer. Inspect the strainer and clean with solvent.

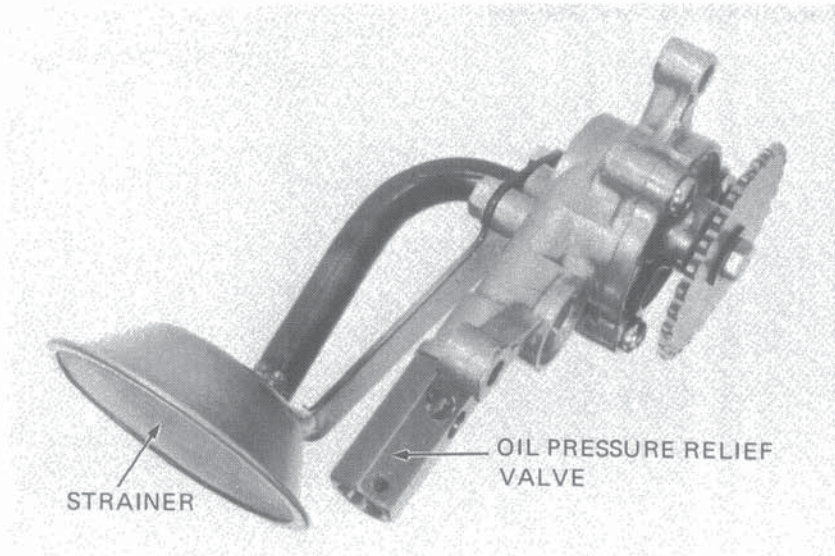

Remove the sprocket.  
Remove the pump cover, thrust washer, pump shaft, and driving pin.  
Remove the inner and outer rotors.

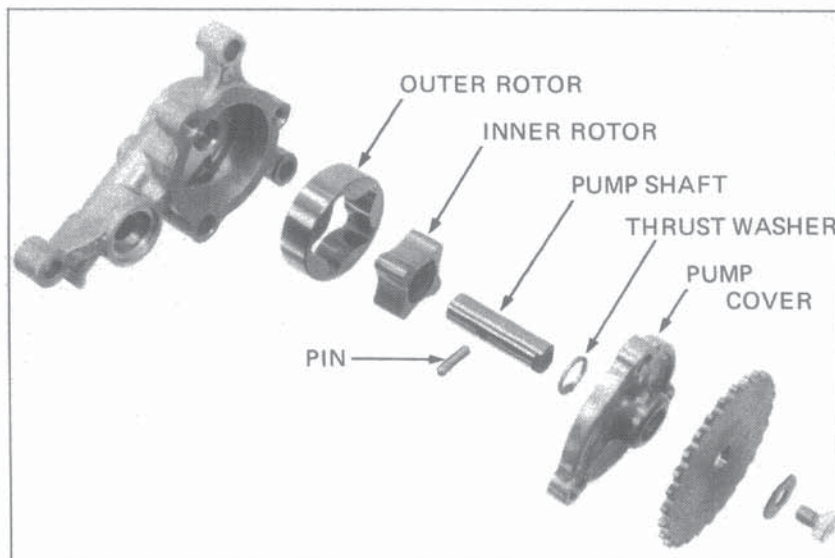

• **OIL PUMP INSPECTION**

Measure pump tip clearance.

SERVICE LIMIT: 0.1 mm (0.004 in.)

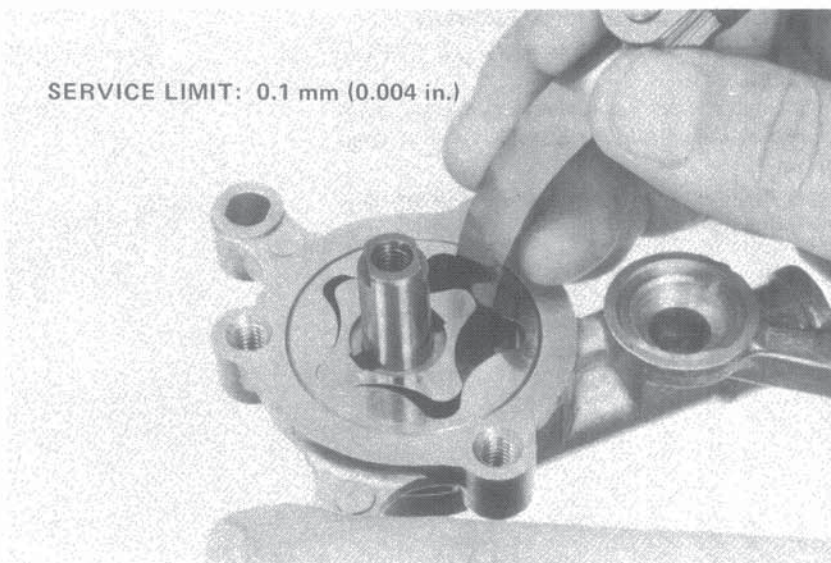





**CLUTCH/OIL PUMP**

Measure the pump body clearance.

SERVICE LIMIT: 0.35 mm (0.014 in.)

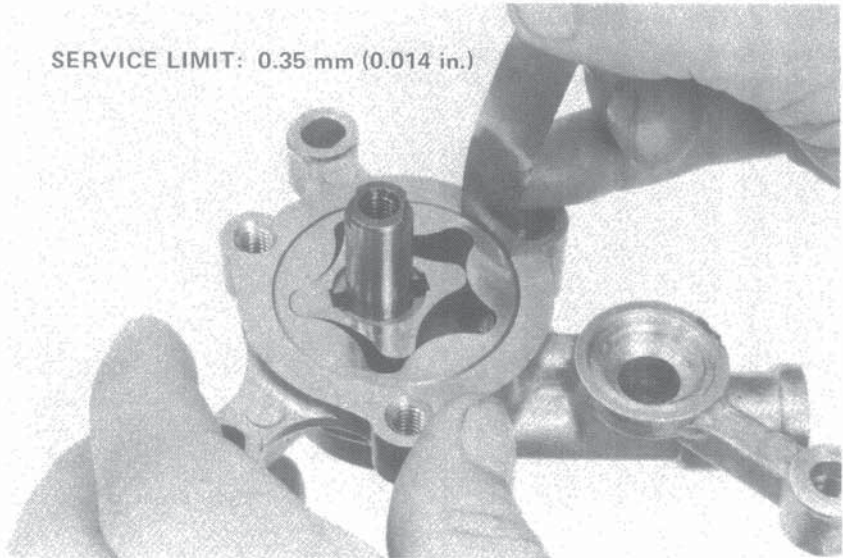

Measure the pump end clearance with a straight edge and feeler gauge.

SERVICE LIMIT: 0.1 mm (0.004 in.)

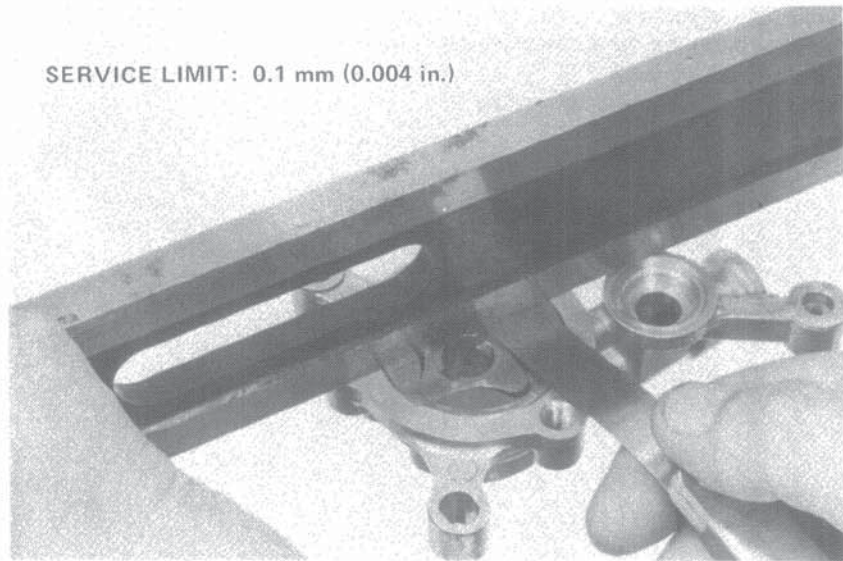

• **RELIEF VALVE INSPECTION**

Remove the valve as an assembly and check its operation.

If the valve does not operate properly, disassemble it and check for a stuck valve or weak spring.

Replace the relief valve as a unit if the spring or plunger is damaged.

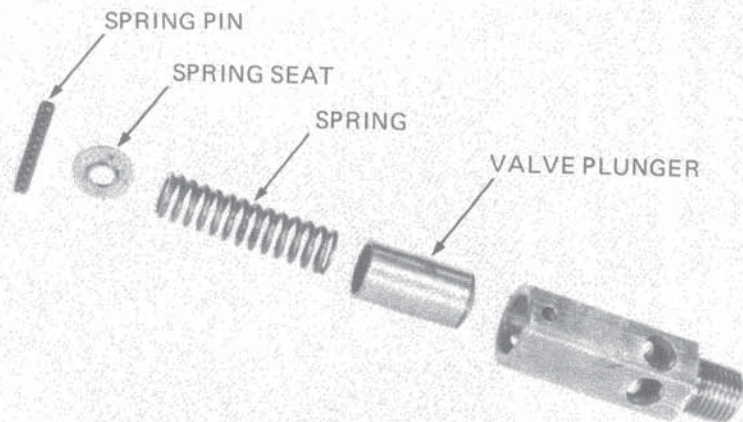





**• OIL PUMP ASSEMBLY**

Insert the outer and inner rotors into the pump body.  
Slide the drive pin into the pump shaft, and install the shaft.  
Install the thrust washer and drive pin.  
Install the pump cover.

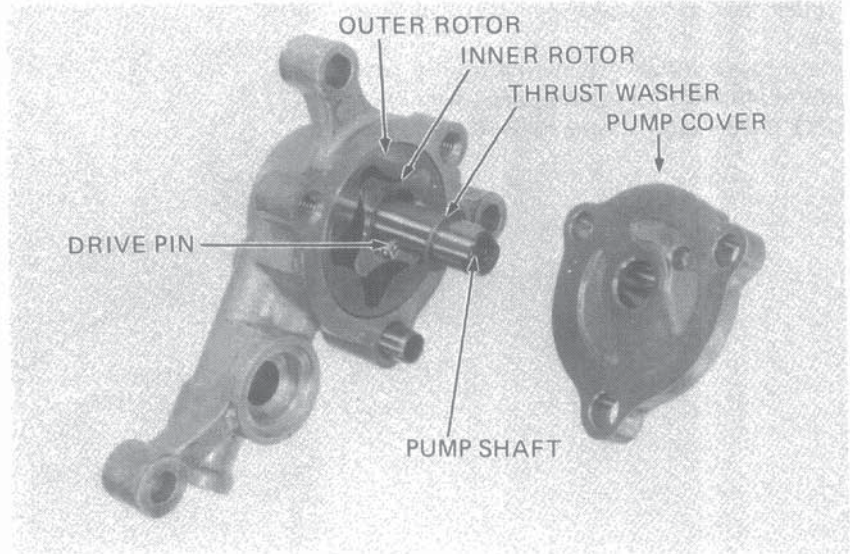

Install the oil strainer.  
Install the oil pressure relief valve and pump sprocket. Do not tighten at this time.

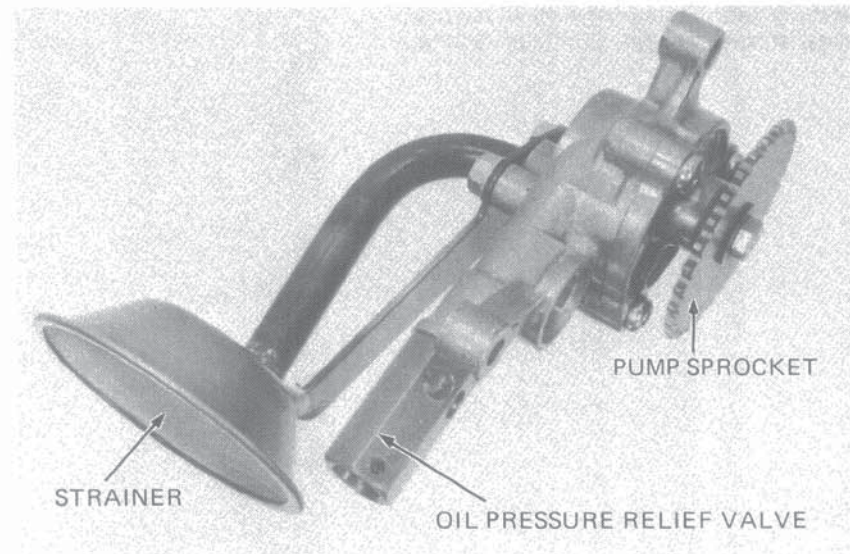

**OIL PUMP INSTALLATION**

Install the dowel pin.  
Install the oil pump.  
Do not tighten the mounting bolts at this time.  
Place the drive chain over the pump and drive sprockets.

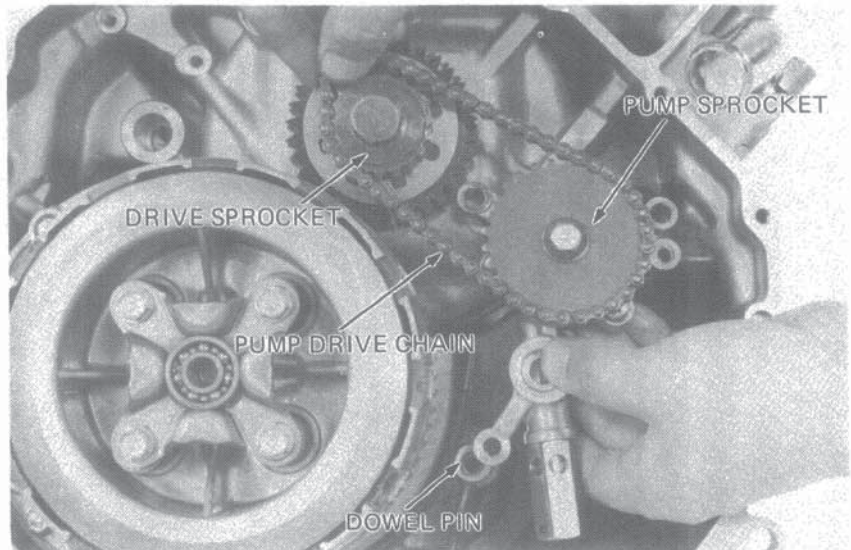





**CLUTCH/OIL PUMP**

Tighten the pump sprocket bolt and relief valve.

Adjust the chain free play by rotating the pump right or left, then torque the pump bolts.

**FREE PLAY: 2.0–3.5 mm (0.8–0.14 in.)**

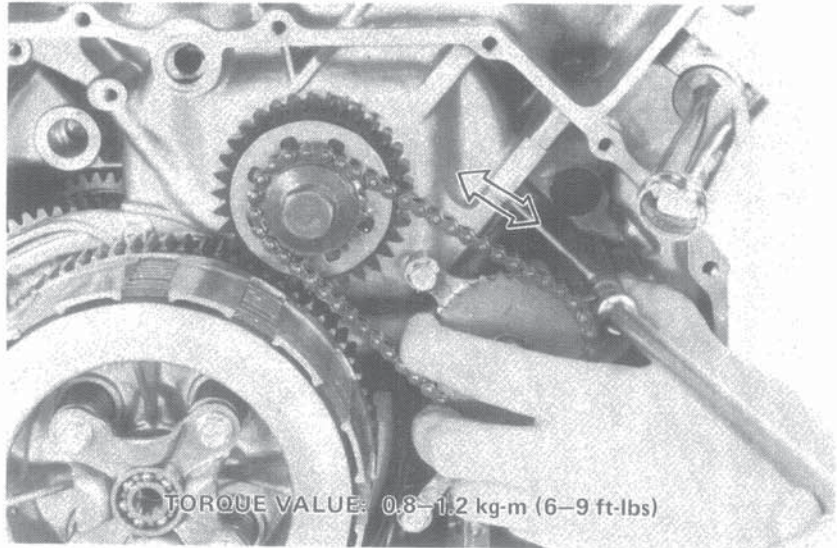

Recheck the oil pump drive chain free play.

**FREE PLAY: 2.0–3.5 mm (0.08–0.14 in.)**

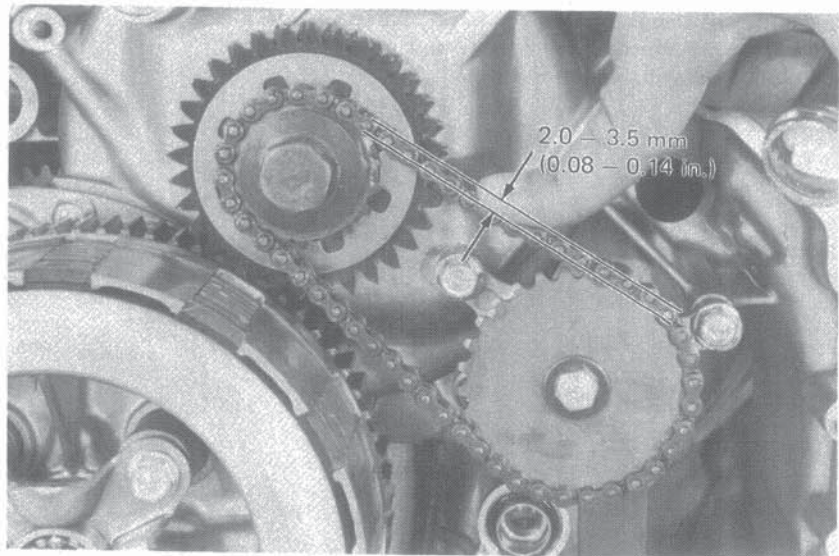

Install the dowel pins, collars, O-rings and gasket.

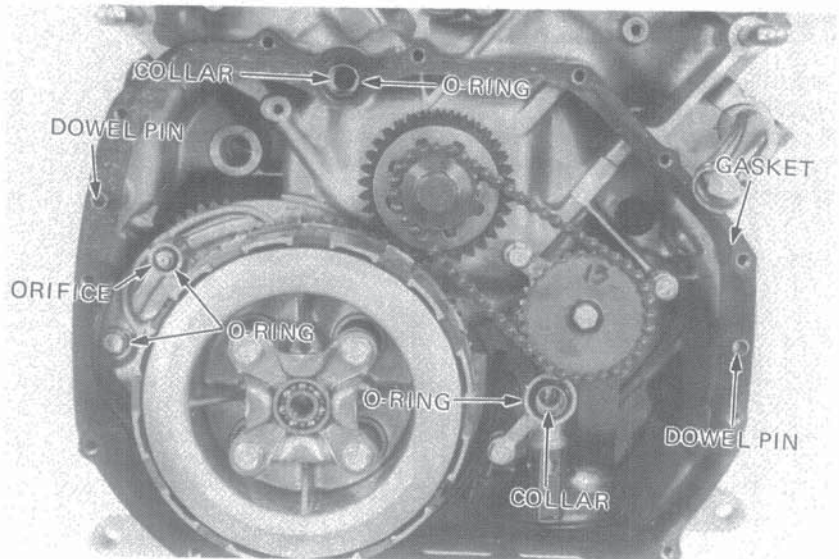



**CLUTCH/OIL PUMP**

Install the transmission cover.  
Connect the oil pressure switch.

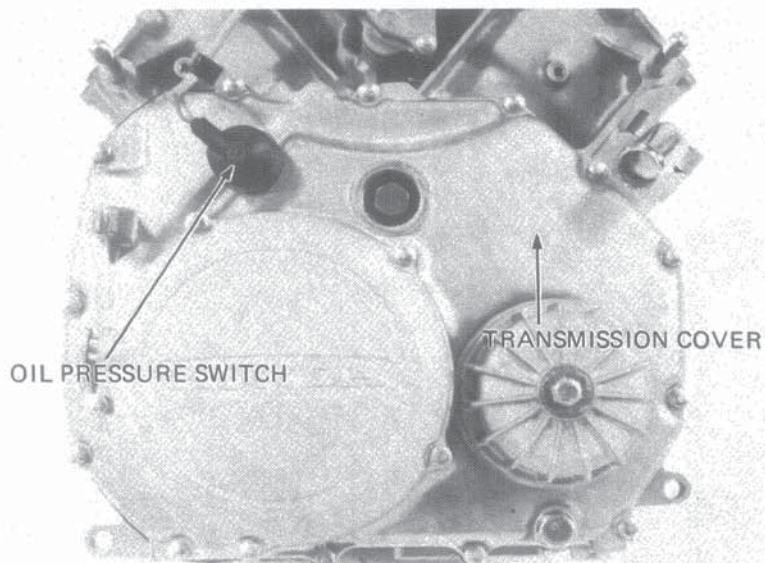

Connect the clutch cable.  
Adjust the clutch free play.  
Install the radiator and fill to the proper level  
with coolant.

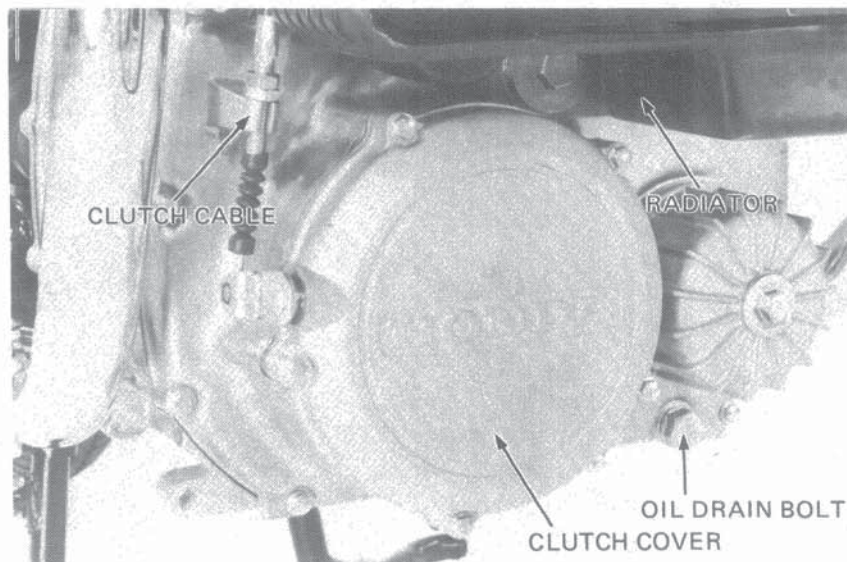



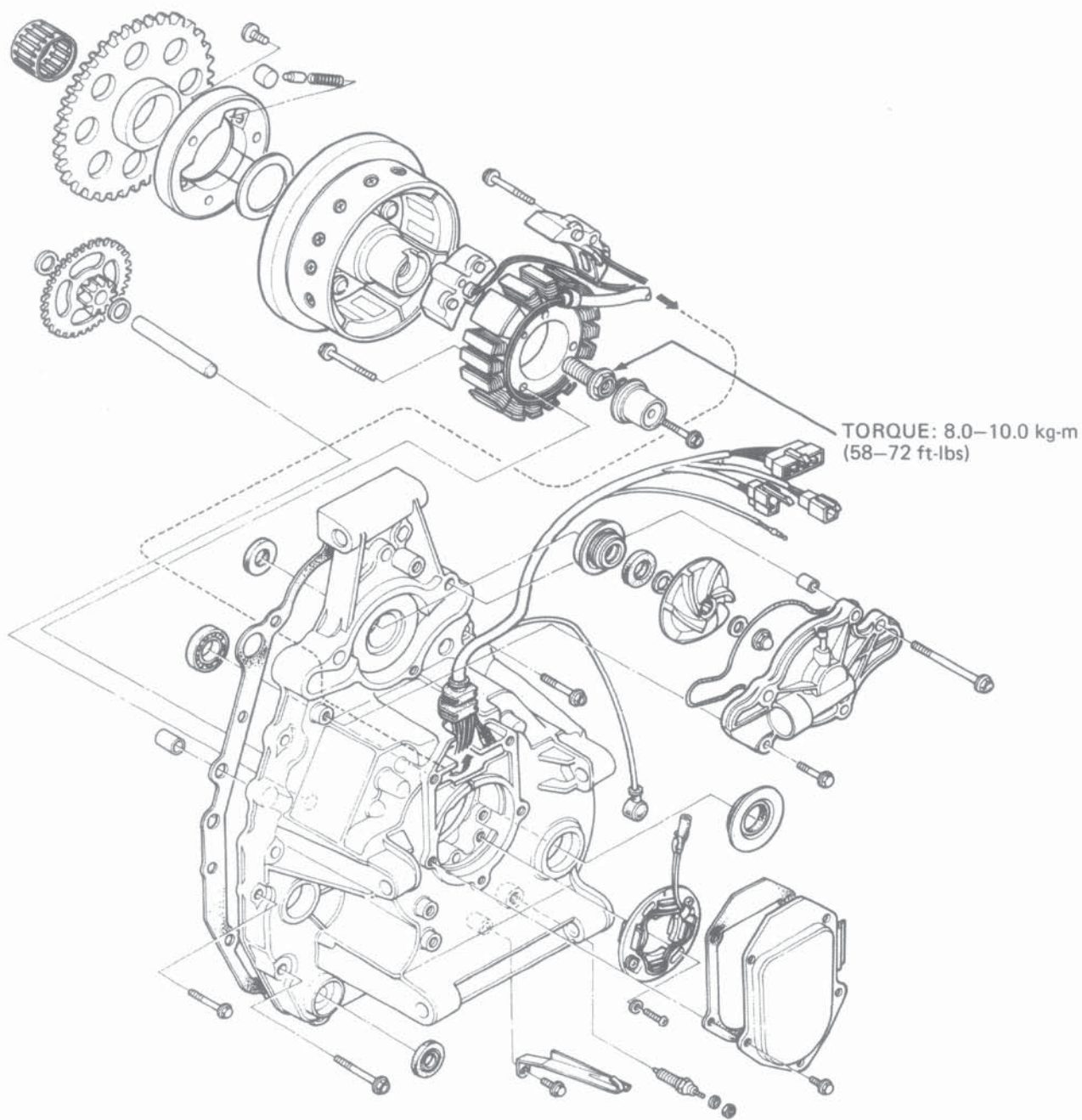



# 8. A.C. GENERATOR/ FLYWHEEL/REAR COVER

SERVICE INFORMATION	8-1	STARTER CLUTCH OUTER INSTALLATION	8-6
COMPONENTS REMOVAL	8-2	FLYWHEEL INSTALLATION	8-7
FLYWHEEL REMOVAL	8-4	COMPONENTS ASSEMBLY	8-8
STARTER CLUTCH OUTER REMOVAL	8-5		

## SERVICE INFORMATION

### • WORKING PRACTICE

Care should be taken to prevent the A.C. generator and pulser from being damaged when disassembling and reassembling them. When the C.D.I. pulser stator is removed, be sure to align the timing mark on the stator with the index mark on the case cover during reassembly.

The A.C. generator stator can be serviced without removing the A.C. generator assembly.

### • SPECIAL TOOLS

#### Special tools

SOCKET WRENCH (17 x 27 mm)	07907-4150000
GEAR HOLDER	07924-4150000
TORX DRIVER BIT (T40)	07703-0010100

#### Common tools

EXTENSION BAR HANDLE	07716-0020500
ROTOR PULLER	07733-0020000
BEARING DRIVER HANDLE (A)	07749-0010000
BEARING DRIVER OUTER (52 x 55 mm)	07746-0010400
BEARING DRIVER PILOT (22 mm)	07746-0041000





## COMPONENTS REMOVAL

Remove the engine from the frame (Page 5-2).  
 Remove the rear cover (Page 9-6).

### • REAR COVER DISASSEMBLY

Remove the water pump mechanical seal (Page 9-6).  
 Remove the starter motor.  
 Remove the C.D.I. pulser cover and neutral switch.  
 Remove the neutral cord guide.  
 Remove the final shaft oil seal.

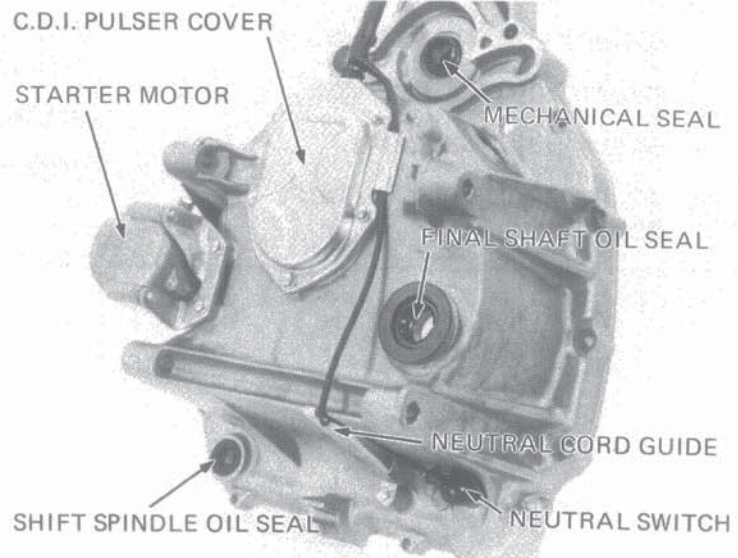

Disconnect the wires at the pulser.  
 Remove the pulser stator.

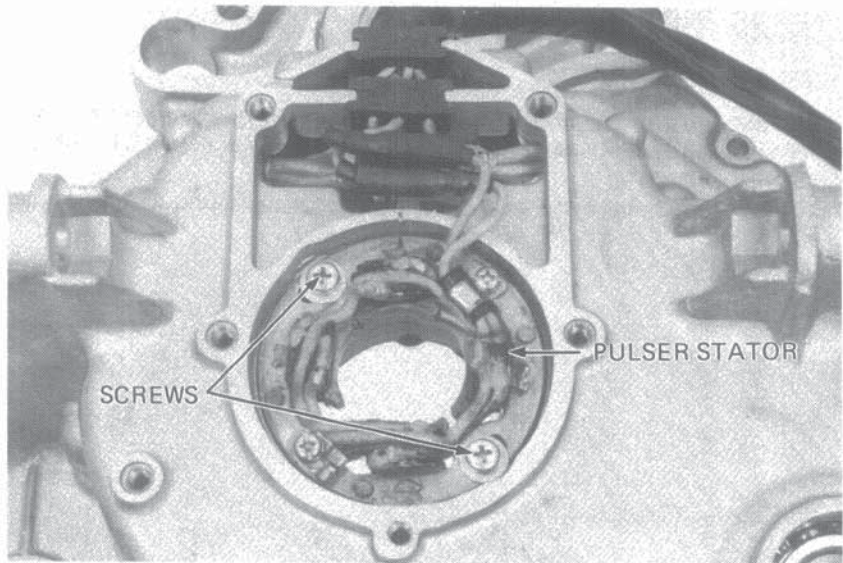

Remove the generator stator and right and left fixed pulsers.

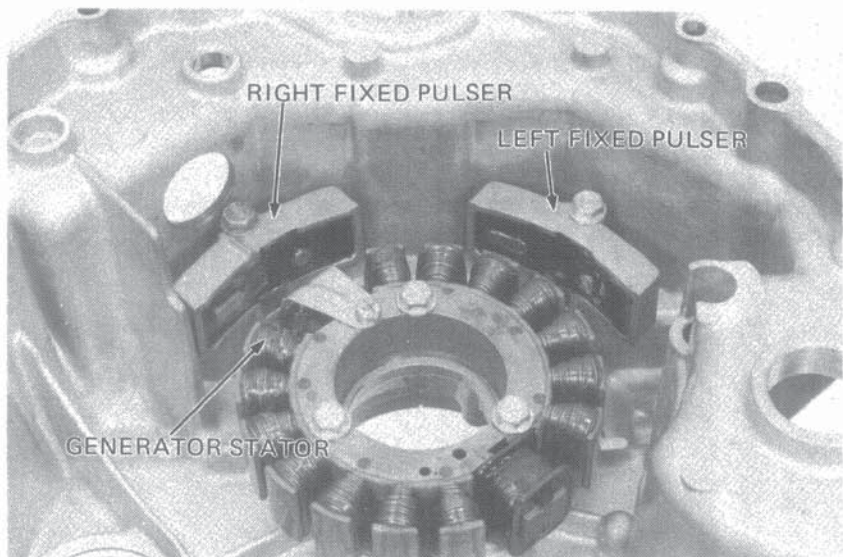





Remove the gearshift spindle oil seal.  
Drive the final shaft bearing out.

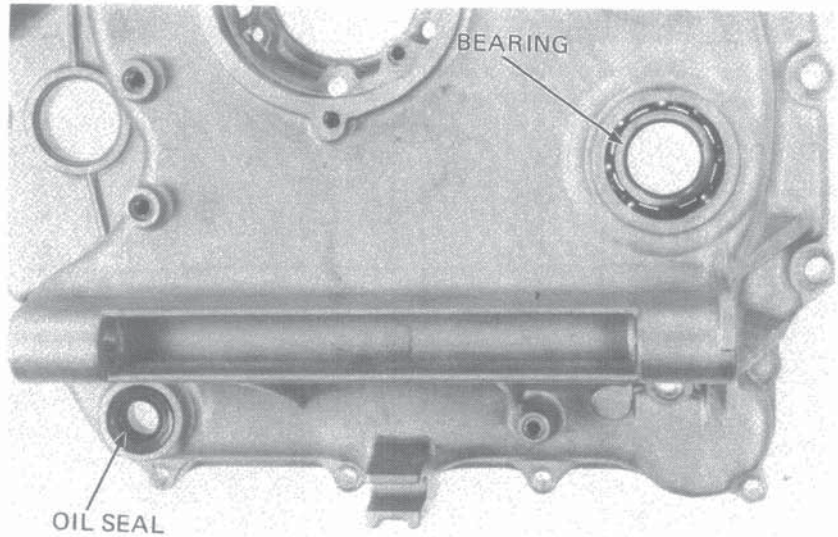

• **NEUTRAL SWITCH INSPECTION**

Check the neutral switch for continuity between the top and bottom terminals. The switch is normal if there is continuity.

Check for shorts between the top terminal and body ground. Replace the switch if there is continuity.

Inspect the neutral switch wire.

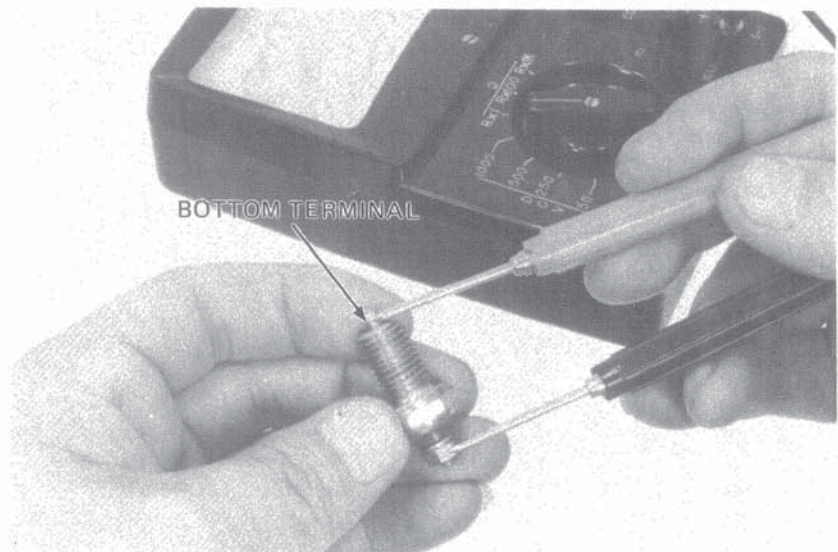
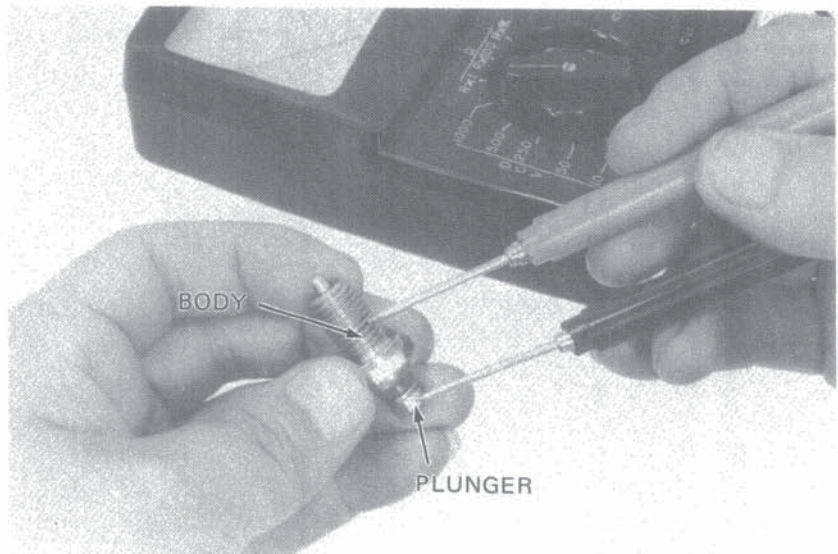

- **STARTER MOTOR INSPECTION**  
(Page 18-3)
- **C.D.I.PULSER INSPECTION** (Page 17-5)
- **A.C.GENERATOR INSPECTION**  
(Page 17-5)





## FLYWHEEL REMOVAL

Remove the transmission cover (Section 7).  
 Attach the GEAR HOLDER to the driven gear.

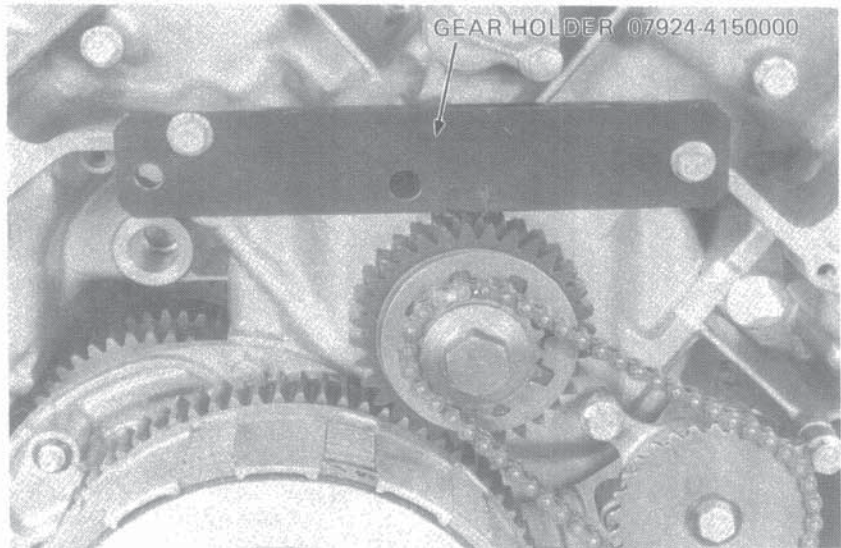

Remove the C.D.I. pulser rotor.  
 Remove the flywheel bolt.

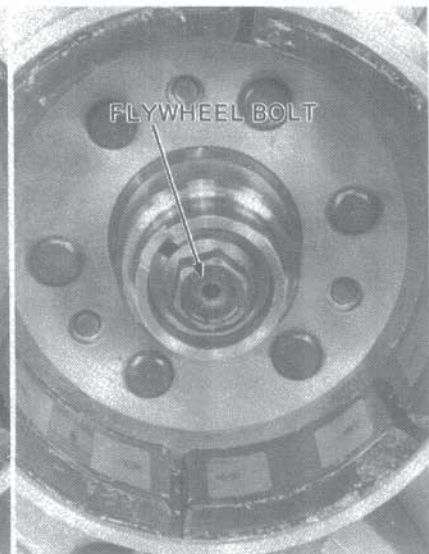
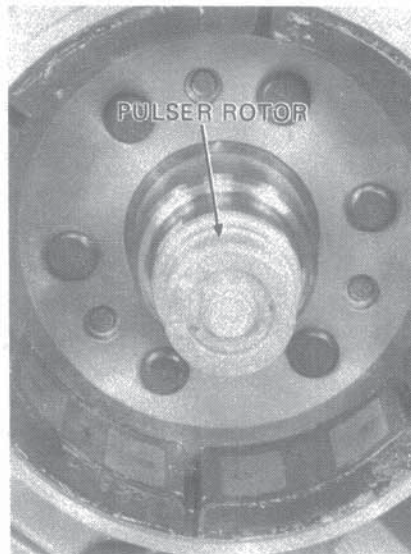

Remove the flywheel.

### NOTE

- Care should be taken not to damage the pulser pick-up on the flywheel outer periphery.
- Use the ROTOR PULLER to remove the flywheel.

Remove the reduction gear shaft.

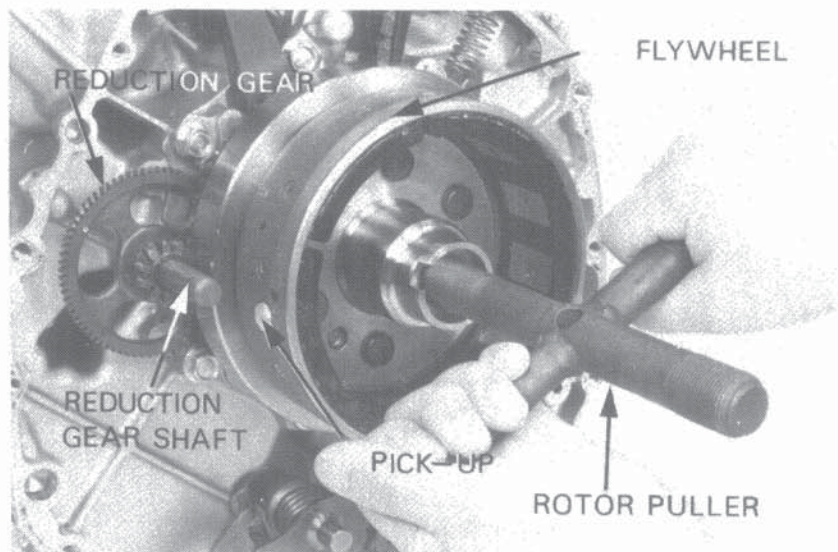





● **REDUCTION GEAR INSPECTION**

Inspect the reduction gear teeth for damage.  
Measure the reduction gear I.D.  
Measure the reduction gear shaft O.D.  
Calculate the gear to shaft clearance.

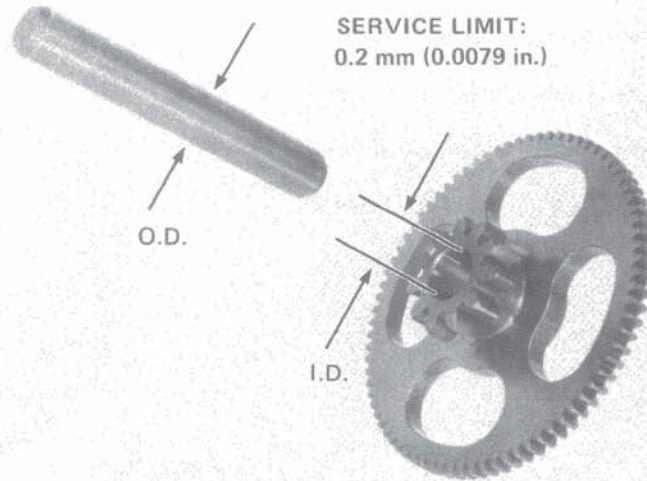

● **STARTER DRIVE GEAR INSPECTION**

Check the drive gear for damage, excessive wear, indentations or other faults. Measure the gear I.D.

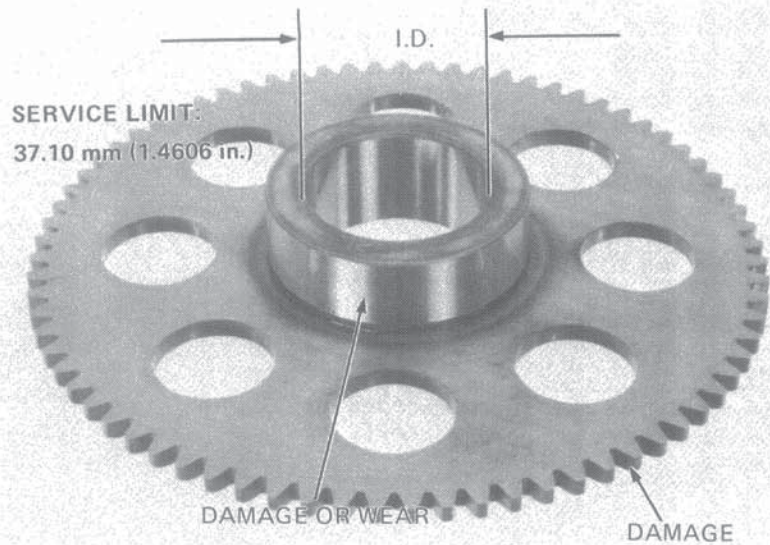

**STARTER CLUTCH OUTER REMOVAL**

Remove the starter clutch rollers, springs and plunger.  
Remove the TORX bolts.

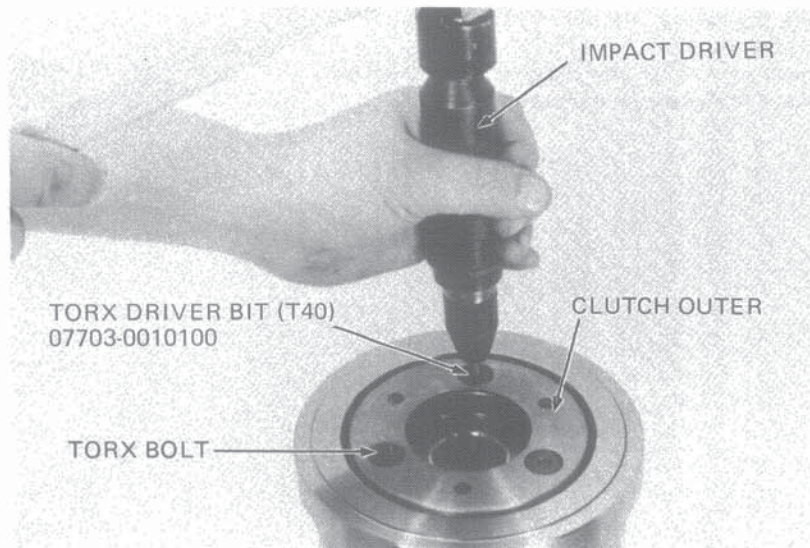





● **STARTER CLUTCH OUTER INSPECTION**

Inspect the rollers for freedom of movement in their grooves.  
 Inspect each roller and replace if it is worn or damaged.  
 Inspect the clutch outer for damaged or worn roller surfaces.  
 Examine the springs and plungers for distortion or excessive wear.

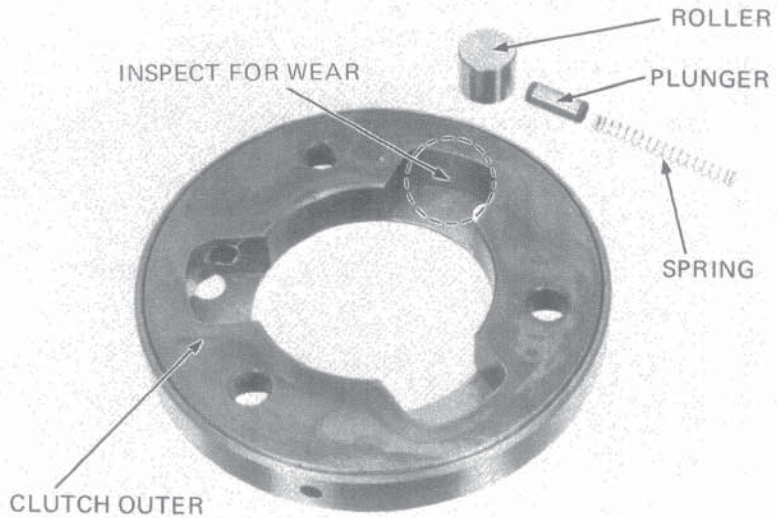

**STARTER CLUTCH OUTER INSTALLATION**

Slide the clutch outer into the flywheel, aligning the holes with the dowel pins in the flywheel.  
 Install and torque the TORX bolts.

**NOTE**

Replace used TORX bolts.

**TORQUE: 2.0-2.5 kg-m (14-17 ft-lbs)**

**NOTE**

Coat the threads and undersides of the TORX bolts with a locking agent, prior to installation.

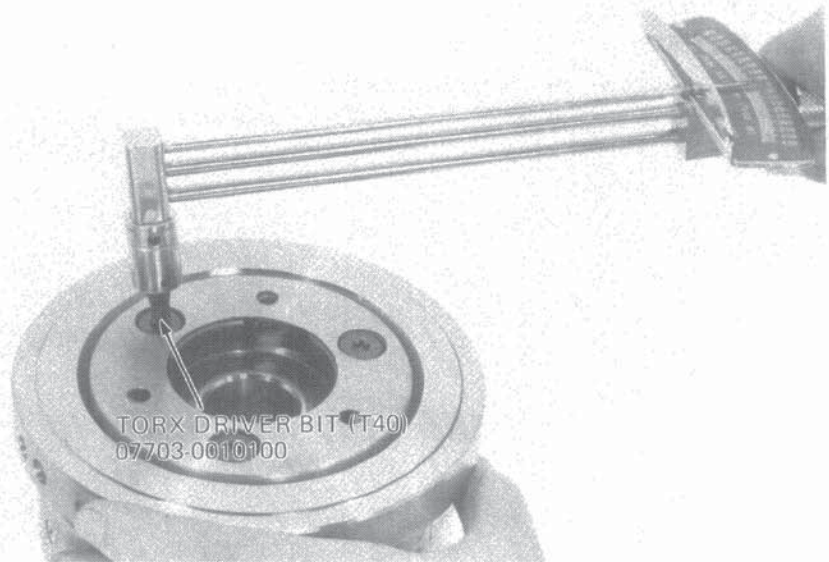

Slide the spring into the plunger and install in the clutch outer.  
 Position the roller into place while holding the plunger with a screwdriver as shown.

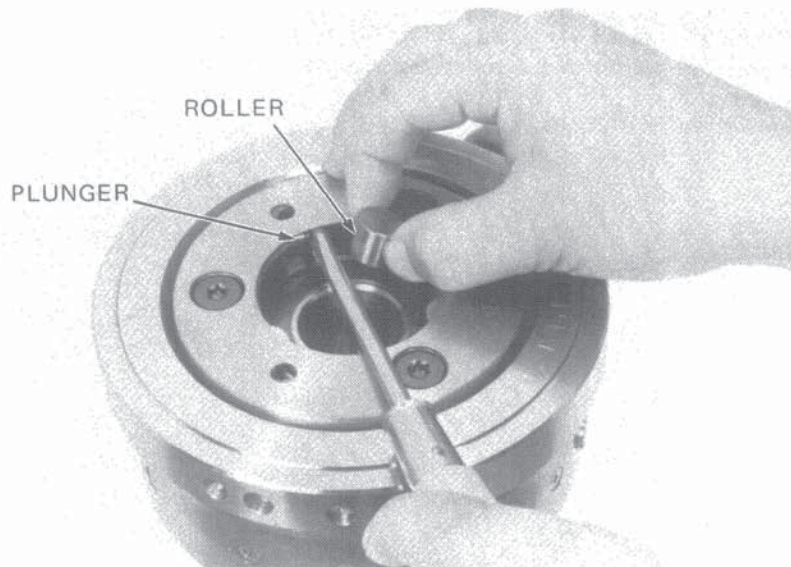





Install the washer.  
Install the starter drive gear on the clutch outer.

**NOTE**

Rotate the drive gear in the counterclockwise direction to aid installation.

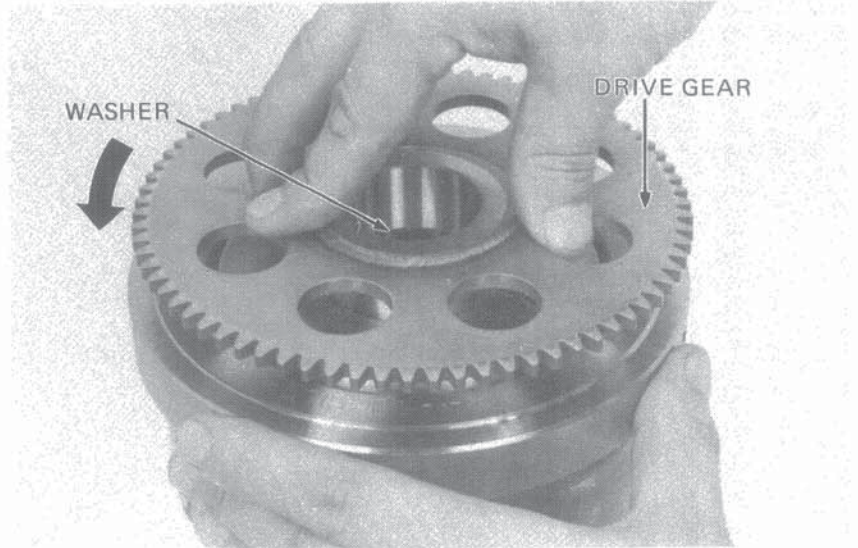

Install the needle roller bearing in the drive gear.

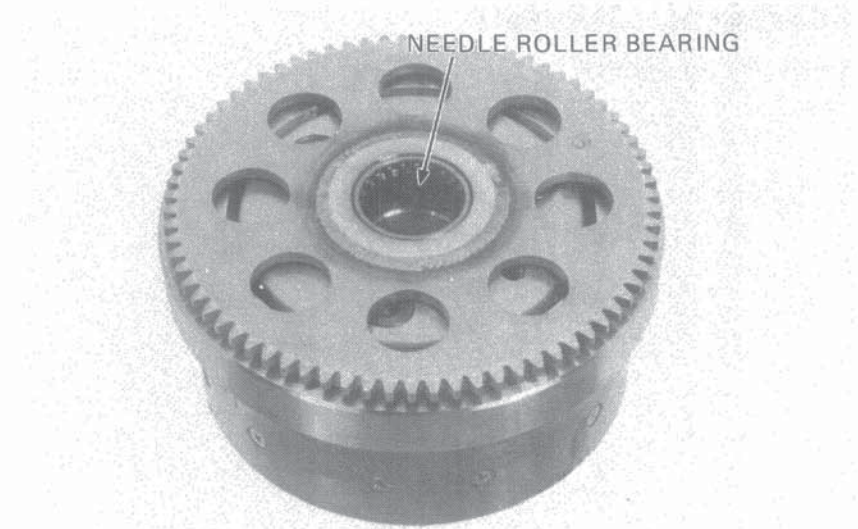

**FLYWHEEL INSTALLATION**

Install the reduction shaft, thrust washers and reduction gear.

**NOTE**

Use two thrust washers, one on each side of the reduction gear.

Install the flywheel and torque the flywheel center bolt.

**TORQUE: 8.0–10.0 kg-m (58–72 ft-lbs)**

**NOTE**

Align the key in the crankshaft with the keyway in the flywheel.

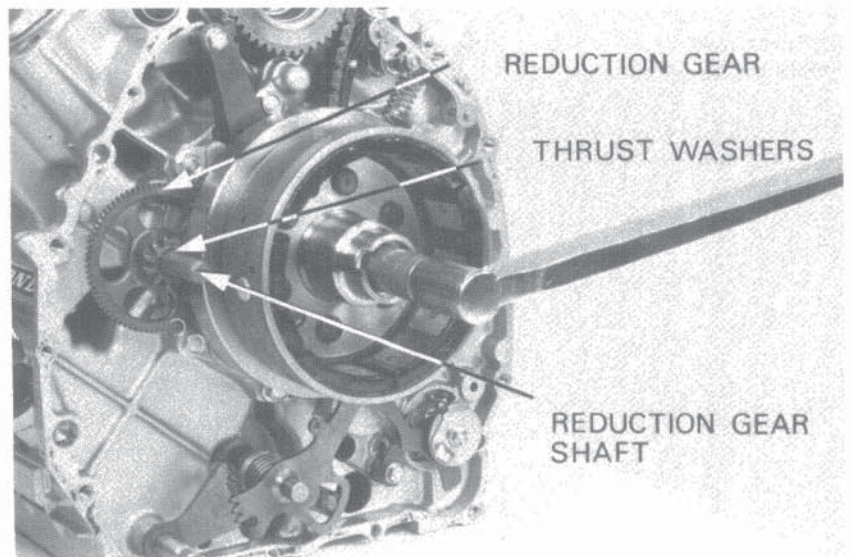





Install the C.D.I. pulser rotor aligning the holding tab with the cutout in the flywheel.

**NOTE**

Replace the pulser rotor and stator as a set.

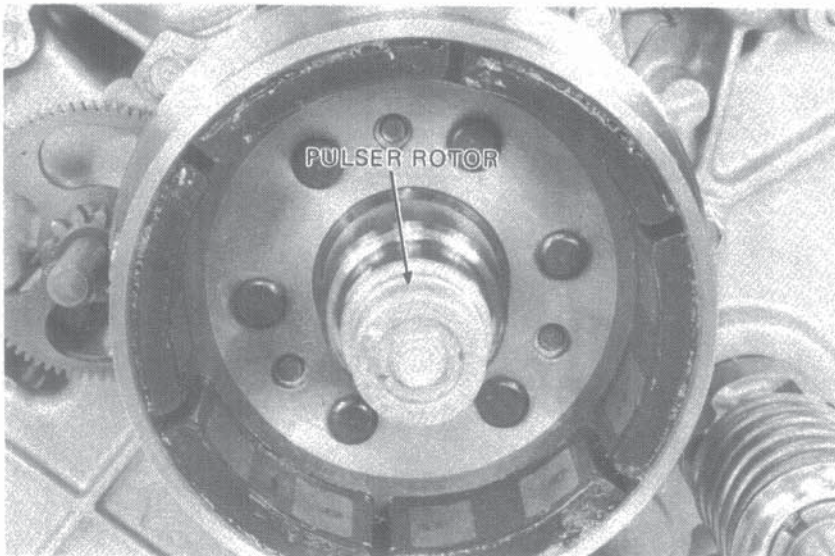

**COMPONENTS ASSEMBLY**

Install the final shaft bearing.

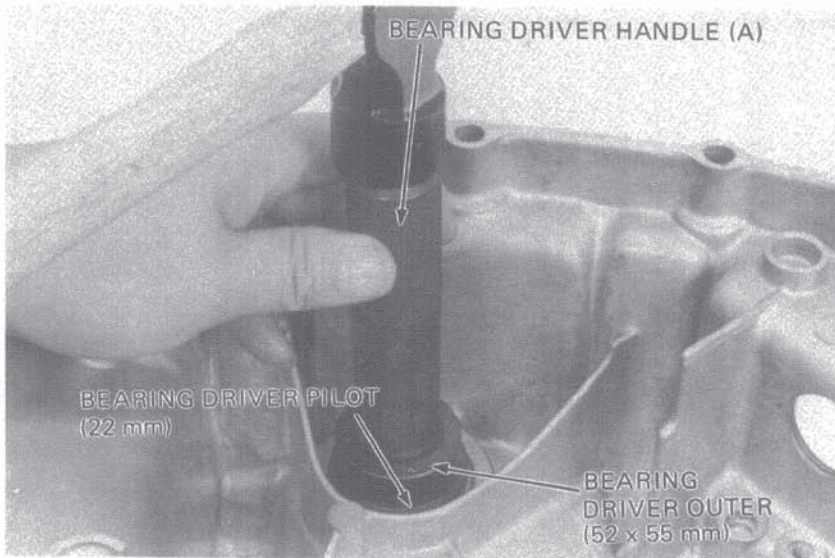

Install the final shaft oil seal and gear shift spindle oil seal.  
Install the neutral switch.

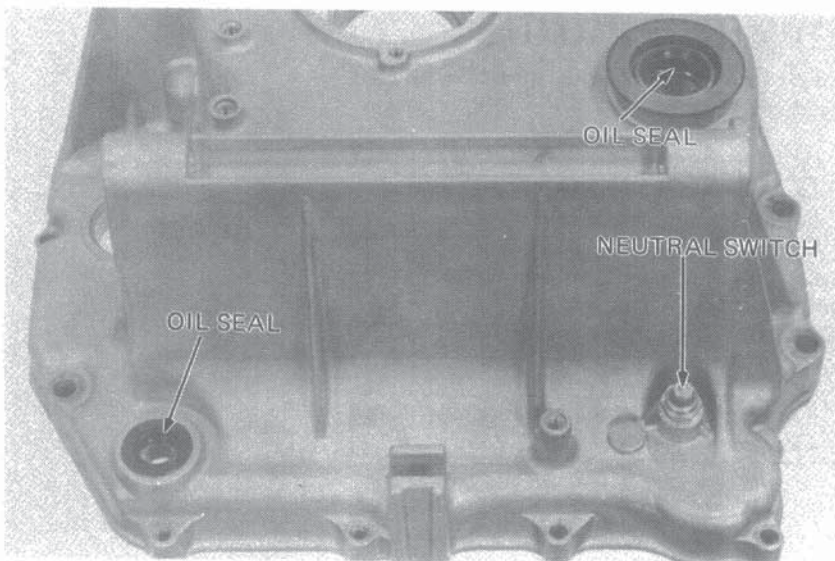





Install the A.C. generator stator and right and left fixed pulsers.

### NOTE

- Install the pulsers with their holding tabs facing the timing inspection window.
- Route the wires properly.

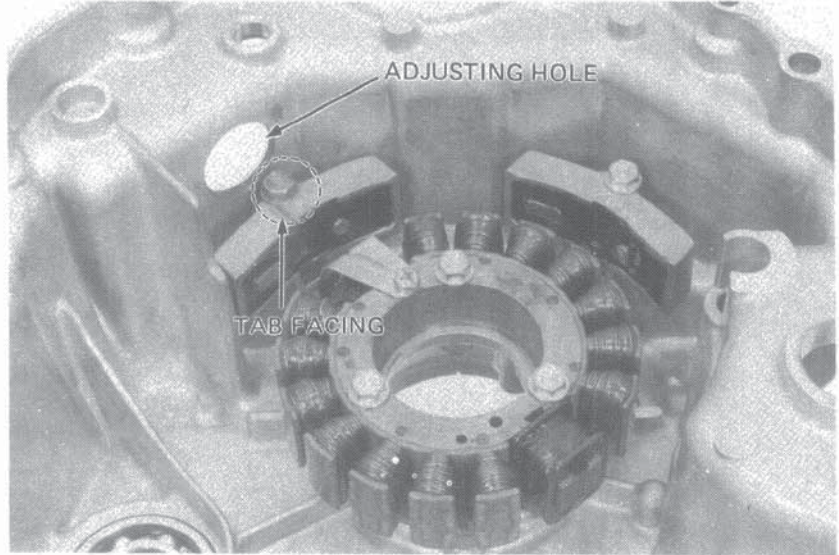

Install the C.D.I. pulser stator.

### NOTE

- Align the marks on the rear cover and stator. If the marks are not aligned, ignition timing will be incorrect.
- Route the wires and cables properly.
- Replace the pulser rotor and stator as a set.

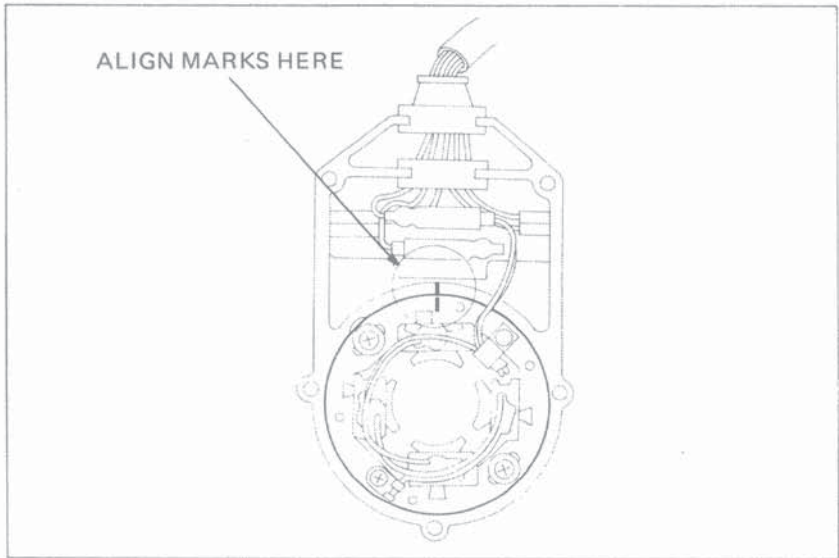

Install the C.D.I. pulser cover.

Connect the neutral switch wires, and secure with the neutral cord guide.

Install the mechanical seal (Page 9-6).

### • ASSEMBLY

Install the following parts:

REAR COVER (Page 9-7)

STARTER MOTOR (Page 9-7)

TRANSMISSION COVER (Page 7-13)

ENGINE (Section 5)

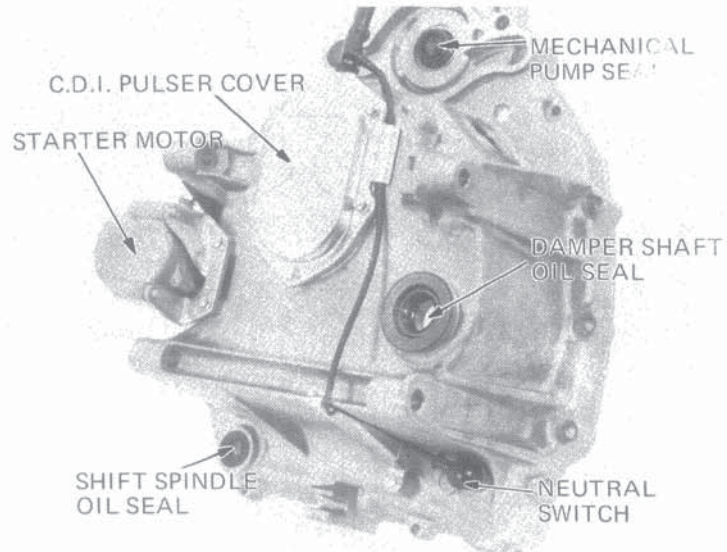





**COOLING SYSTEM**

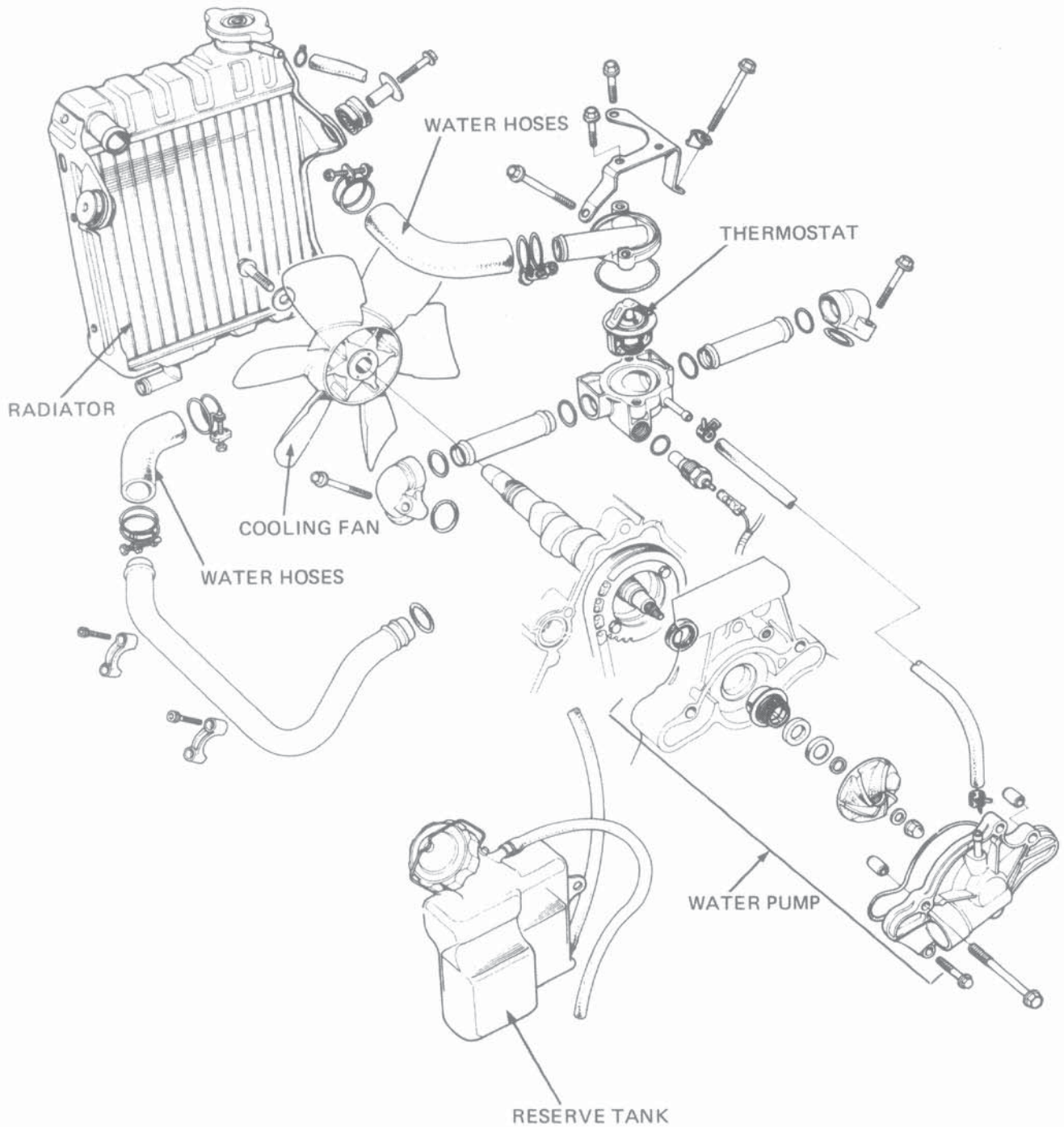



SERVICE INFORMATION	9- 1	WATER PUMP DISASSEMBLY	9- 5
TROUBLESHOOTING	9- 1	WATER PUMP ASSEMBLY	9- 6
SYSTEM TESTING	9- 2	THERMOSTAT INSTALLATION	9- 9
COOLANT REPLACEMENT	9- 3	COOLING FAN INSTALLATION	9- 9
THERMOSTAT REMOVAL	9- 3	RADIATOR INSTALLATION	9-10
COOLING FAN REMOVAL	9- 5		

## SERVICE INFORMATION

### • WORKING PRACTICE

To service the water pump seal, it is necessary to remove the rear engine cover. All the other cooling system services can be made with the engine in the frame.

Do not remove the radiator cap when the engine is hot. The coolant is under pressure and severe scalding could result. The engine must be cool before servicing the cooling system.

Avoid spilling coolant on painted surfaces. After servicing the system, check for leaks with a radiator tester.

### • SPECIAL TOOLS

#### • Special tool

MECHANICAL SEAL DRIVER ATTACHMENT  
07945-4150200

#### • Common tools

FLYWHEEL ROTOR PULLER  
07733-0010000  
DRIVER HANDLE (A)  
07749-0010000  
COOLING SYSTEM TESTER  
M988X-525-XXXXX

### • SPECIFICATIONS

Radiator cap relief pressure	0.75-1.05 kg/cm <sup>2</sup> (10.7 - 14.9 psi)
Freezing point (Hydrometer test):	55% Distilled water + 45% ethylene glycol: -32°C (-25°F) 50% Distilled water + 50% ethylene glycol: -37°C (-34°F) 45% Distilled water + 55% ethylene glycol: -44.5°C (-48°F)
Coolant capacity: Radiator and engine Reserve tank Total system	1.8 liters (1.9 U.S. qt) 0.2 liters (0.21 qt.) 2.0 liters (2.16 qt.)
Thermostat	Begins to open: 80° to 84°C (176° to 183°F) Fully open: 93° to 97°C (199° to 205°F) Valve lift: Minimum of 8 mm at 95°C (0.315 in. at 203°F)
Boiling point (with 50-50 mixture):	Unpressurized: 107.7°C (226°F) Cap on, pressurized: 125.6°C (258°F)

## TROUBLESHOOTING

### Engine Temperature Too High

- Faulty temperature gauge or gauge sensor
- Thermostat stuck closed
- Faulty radiator cap
- Insufficient coolant
- Passages blocked in radiator, hoses, or water jacket
- Fan blades bent

### Engine Temperature Too Low

- Faulty temperature gauge or gauge sensor
- Thermostat stuck open

### Coolant Leaks

- Faulty pump oil seal
- Deteriorated O-rings





## SYSTEM TESTING

### • COOLANT

Test the coolant mixture with an antifreeze tester. For minimum corrosion protection, a 50–50% solution of ethylene glycol and distilled water is recommended.

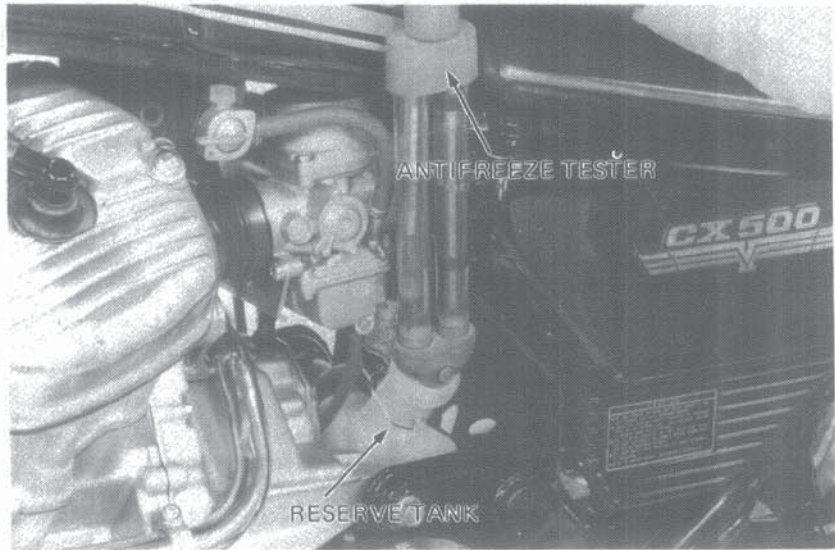

### • RADIATOR CAP INSPECTION

Pressure test the radiator cap. Replace the radiator cap if it does not hold pressure, or if relief pressure is too high or too low. It must hold specified pressure for at least six seconds.

#### NOTE

Before installing the cap on the tester, apply water to the sealing surfaces.

**RADIATOR CAP RELIEF PRESSURE:**  
 $0.9 \pm 0.15 \text{ kg/cm}^2$  (12.8  $\pm$  2.1 Psi)

**COOLING SYSTEM TESTER**  
M988X-525-XXXXX

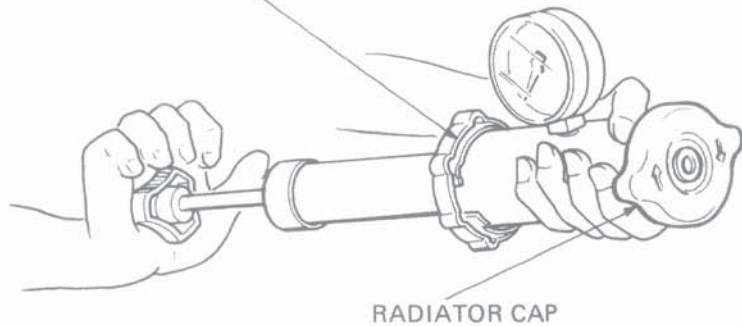

Pressurize the radiator, engine and hoses, and check for leaks.

#### CAUTION

*Excessive pressure can damage the radiator.*  
*Do not exceed  $1.05 \text{ kg/cm}^2$  (14.9 Psi)*

Repair or replace components if the system will not hold specified pressure for at least six seconds.

**COOLING SYSTEM TESTER**  
M988X-525-XXXXX

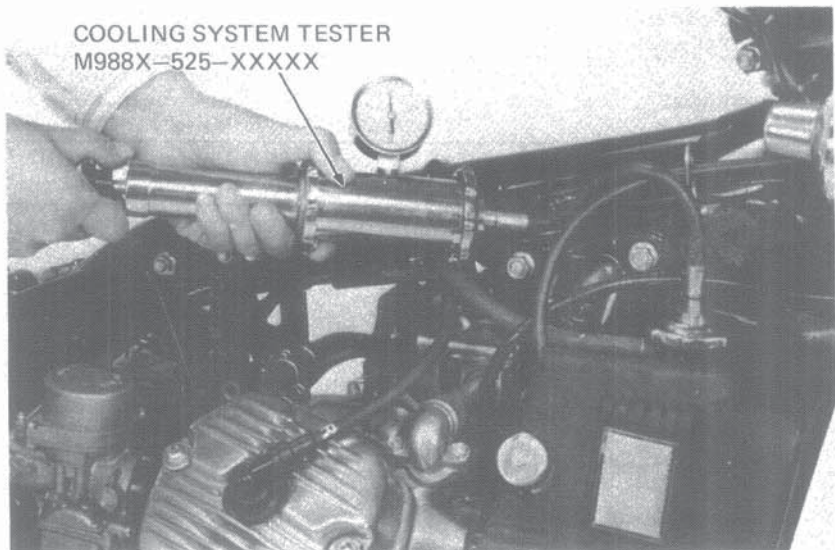





## COOLANT REPLACEMENT

### WARNING

*Engine must be cool before servicing the cooling system, or severe scalding may result.*

- Remove the seat and fuel tank.
- Remove the radiator cap.
- Remove the radiator cover grommets and 6 mm screws.
- Remove the radiator cover.

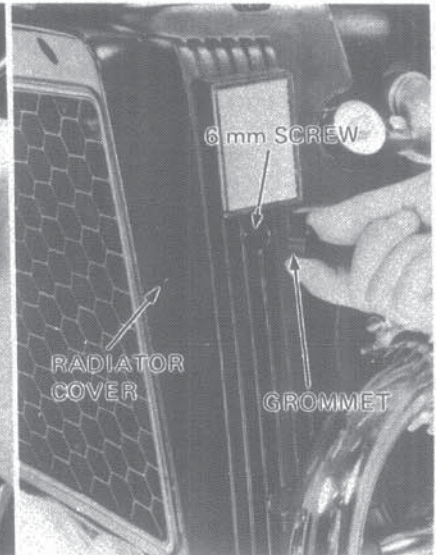

- Remove the radiator drain plug, and drain the coolant (about 1.4 liters).
- To drain coolant from the cylinders, remove the cylinder drain plugs (about 0.4 liters).
- Replace the cylinder and radiator drain bolt.

### CAUTION

*Do not overtighten the radiator drain plug.*

- Fill the system with a 50–50 mixture of distilled water and ethylene glycol.

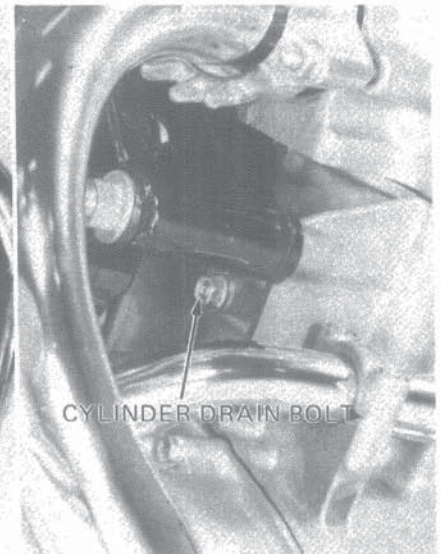
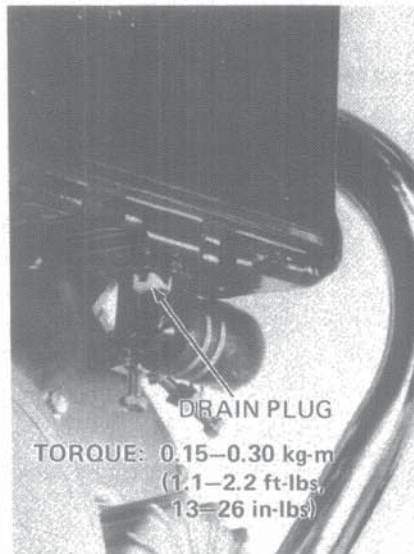

## THERMOSTAT REMOVAL

- Remove the seat and fuel tank.
- Remove the coolant drain plug, and drain the coolant.
- Disconnect the bypass hose.
- Disconnect the temperature unit and oil pressure gauge wires.
- Remove the air spoiler.

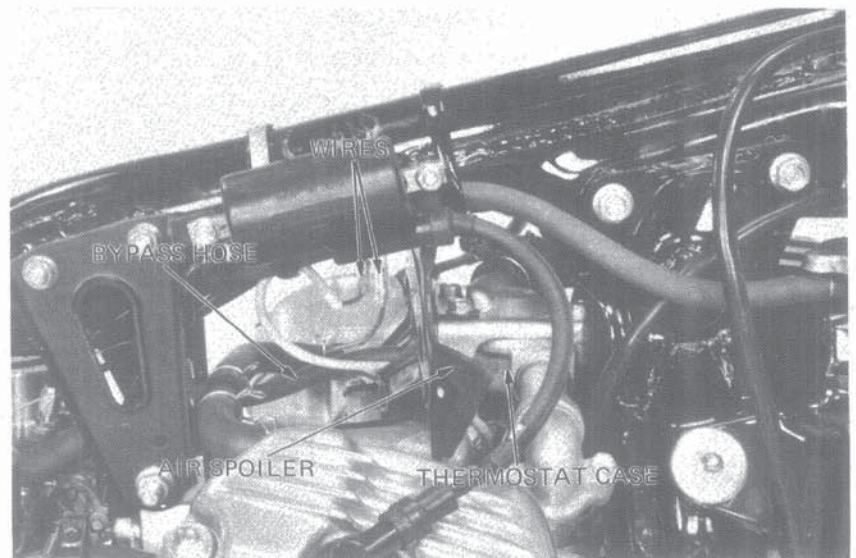





## COOLING SYSTEM

Loosen the radiator hose band and pull the hose off the thermostat cover.  
Remove the thermostat bracket bolts.  
Remove the thermostat assembly.

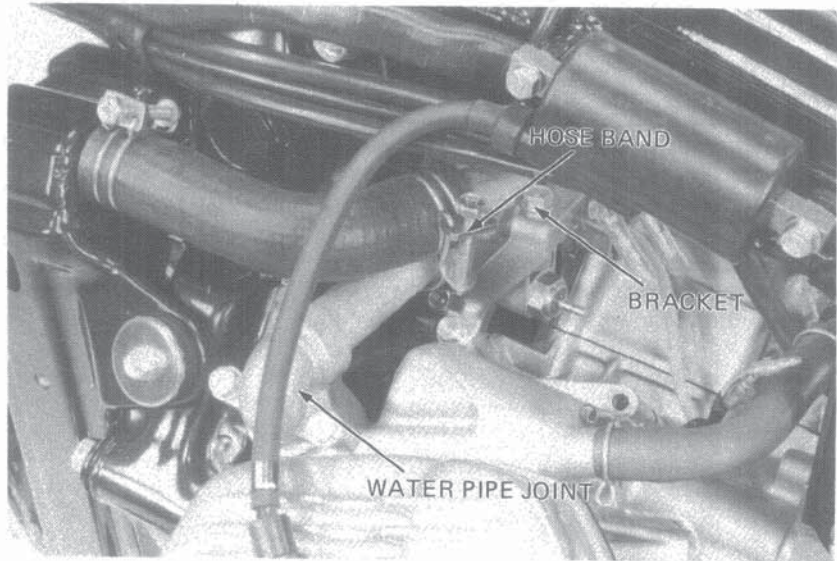

Separate the thermostat bracket from the thermostat housing.  
Remove the thermostat cover and take out the thermostat.  
Disconnect the water pipe.  
Remove the water temperature unit.

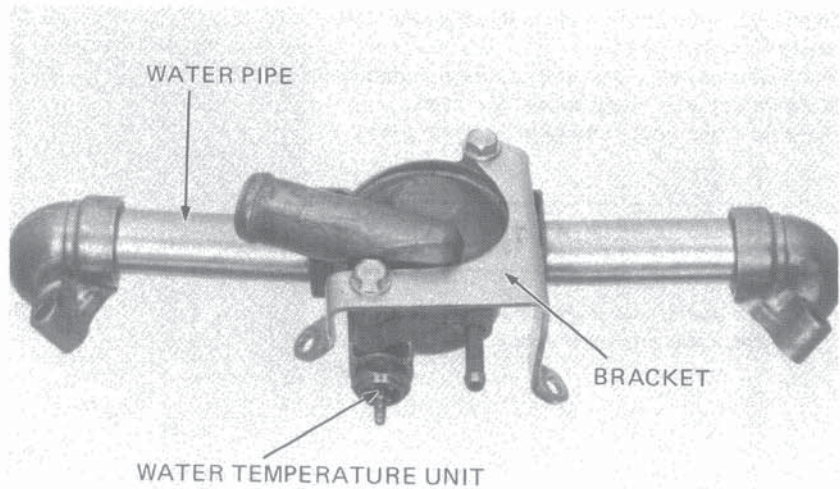

### ● TEMPERATURE UNIT INSPECTION

Suspend the unit in oil and measure the resistance through the unit as the oil heats.

Temperature	60°C	85°C	110°C	120°C
	140°F	185°F	230°F	248°F
Resistance	104.0 Ω	43.9 Ω	20.3 Ω	16.1 Ω

Do not let the unit or thermometer touch the pan or false readings will result.

#### **WARNING**

*Wear gloves and eye protection.*

#### **NOTE**

Oil must be used as the heated liquid to check operation above 100°C (212°F).

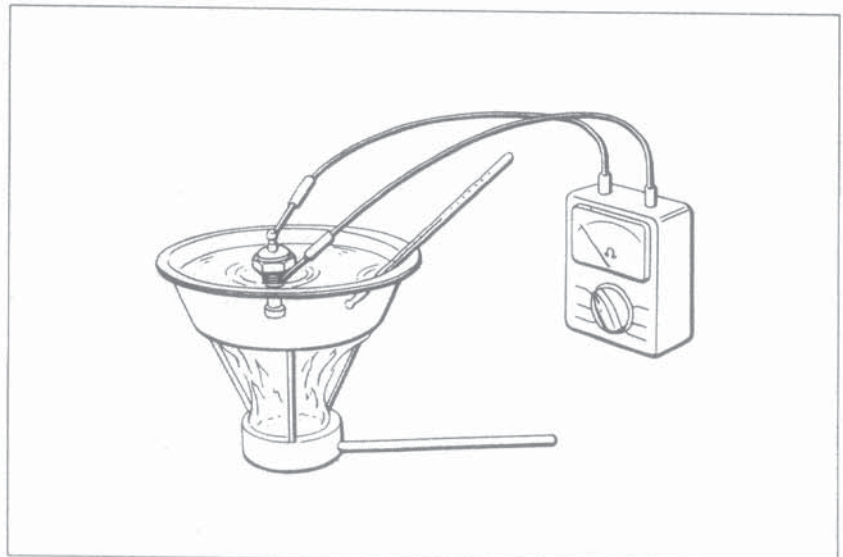





• **THERMOSTAT INSPECTION**

Inspect the thermostat visually for damage. Suspend the thermostat in hot water to check operation.

Do not let the thermostat or thermometer touch the pan or false readings will result.

**Technical Data**

Start to open	80° to 84°C (176° – 183°F)
Fully open	95°C (203°F)
Valve lift	8 mm minimum (0.31 in)

**NOTE**

- Replace thermostat if valve stays open at room temperature, or if it responds at temperatures other than those specified.
- Valve lift must be checked by applying heat for five minutes.

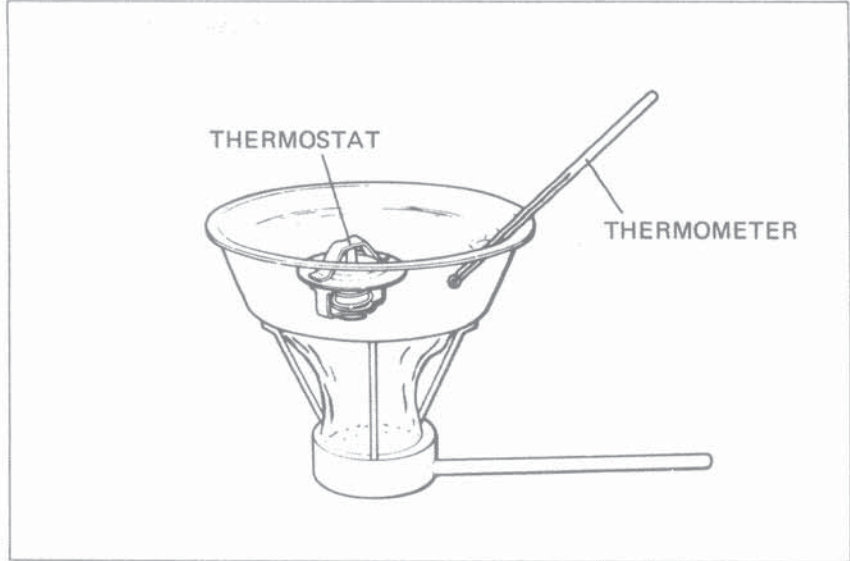

**COOLING FAN REMOVAL**

- Remove the seat and fuel tank.
- Remove the radiator (Page 5–6),
- Remove the crankshaft hole cap and hold the crankshaft.
- Remove the fan bolts.
- Remove the fan.

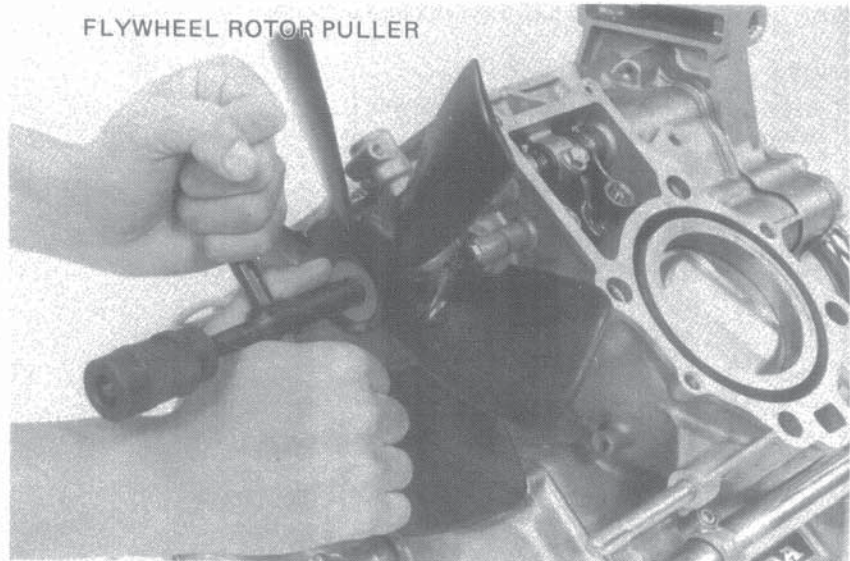

**WATER PUMP DISASSEMBLY**

- Remove the engine from the frame (Page 5–2).
- Disconnect the water pipes.
- Remove the water pump cover.

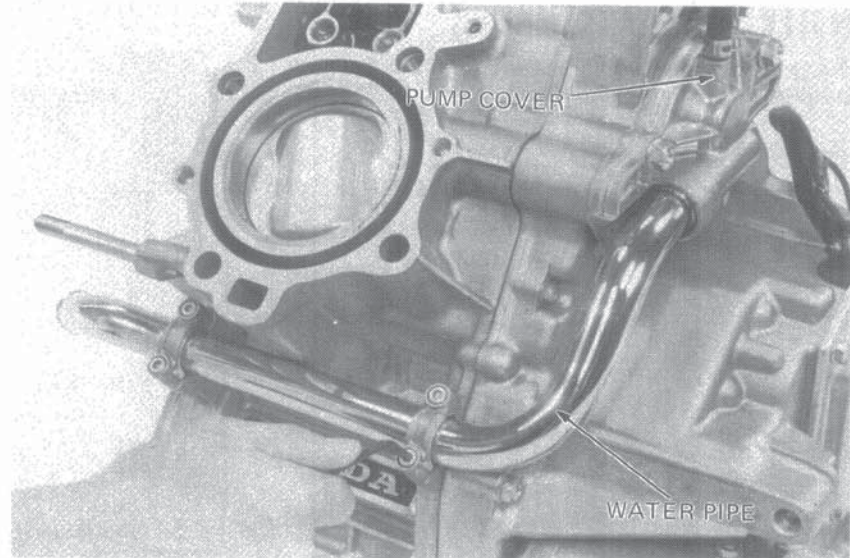





**COOLING SYSTEM**

- Remove the cap nut, copper washer and impeller.
- Remove the starter motor.
- Remove the rear cover bolts.
- Remove the rear cover.

**NOTE**

Inspect the impeller for wear or damage.

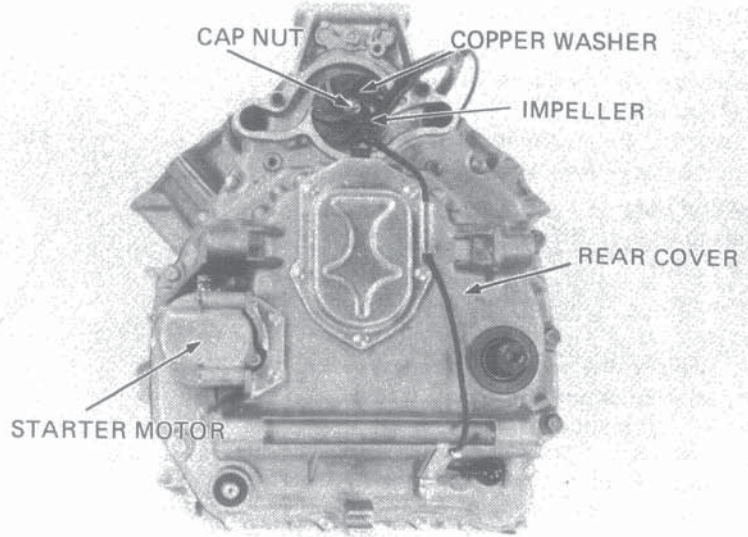

Drive the mechanical seal out from the inside.

**NOTE**

Avoid damaging the rear cover when driving the seal out.

Inspect the mechanical seal for damage or evidence of deterioration.

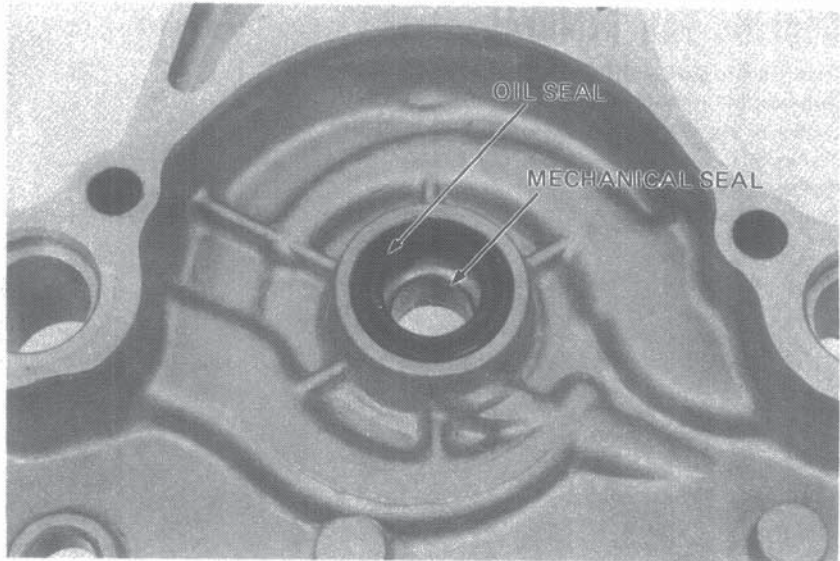

**WATER PUMP ASSEMBLY**

Apply a thin coat liquid sealant to the outer-periphery of the mechanical seal.

**NOTE**

Check that the water pump drain hole is clear.

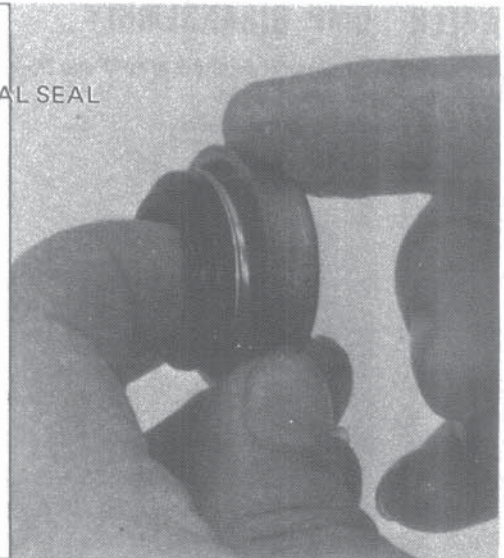
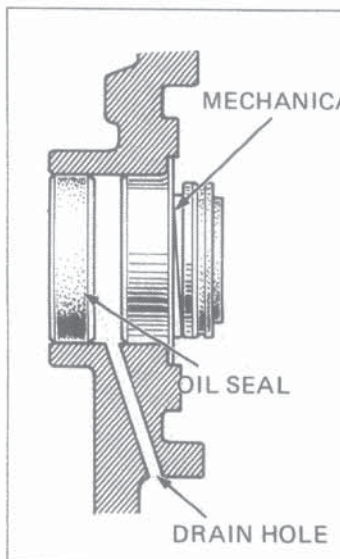





Drive the mechanical seal into position in the rear cover with the mechanical seal driver attachment, bearing driver handle and mechanical seal pilot.

### NOTE

- Assemble the driver as follows:  
Install the seal driver attachment to the driver handle. Place the mechanical seal into the attachment and hold it in place by screwing in the seal pilot. (See the illustration)
- Drive in the seal squarely.
- Remove the seal pilot after driving in the seal.

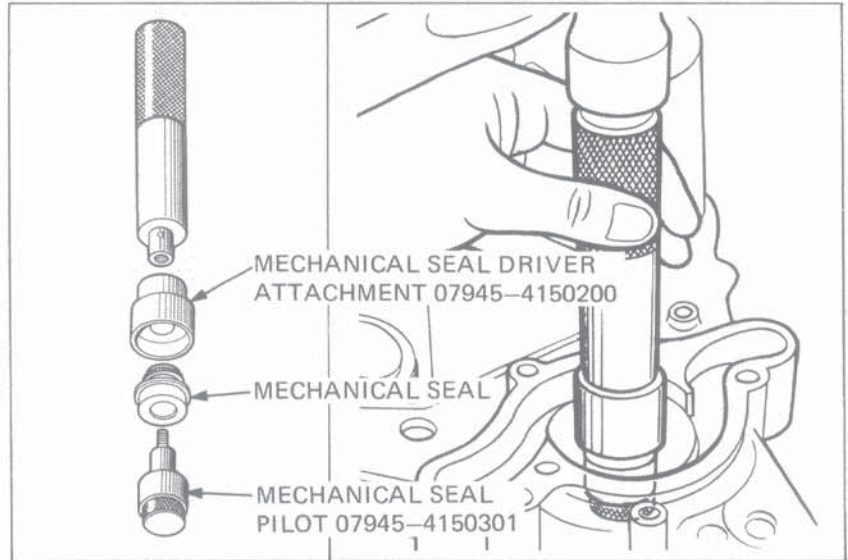

Install the collars, O-rings, dowel pins and rear cover gasket.

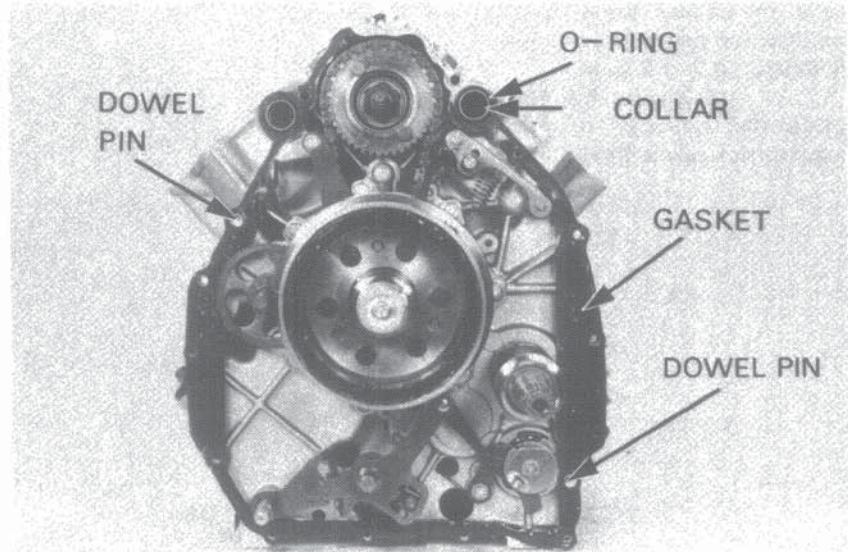

Install the rear cover and torque the bolts.

### TORQUES:

- 6 mm bolts: 0.8–1.2 kg-m (6–9 ft-lbs)
- 8 mm bolts: 1.8–2.5 kg-m (13–18 ft-lbs)

Install the starter motor.

### NOTE

Engage the starter drive gear with the reduction gear before tightening the cover.

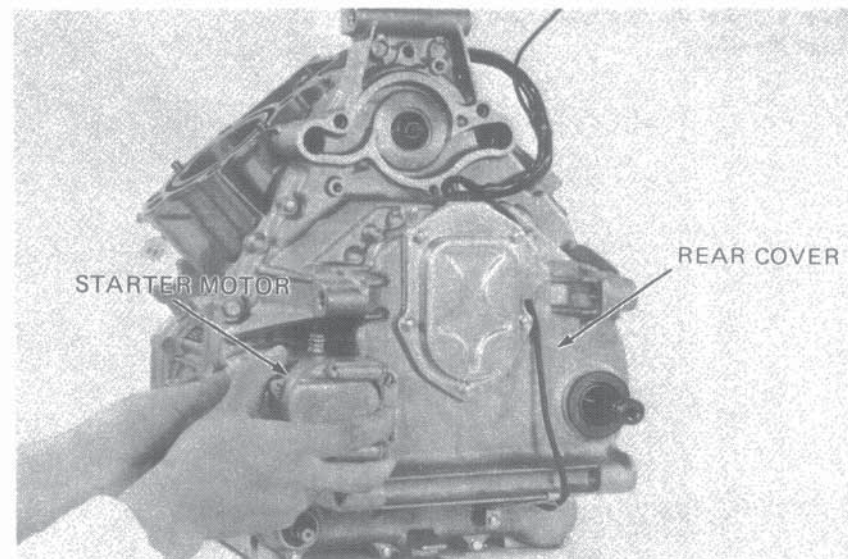





**COOLING SYSTEM**

Install the seal rubber and seal washer in the impeller and apply soapy water to the sliding surfaces.

**NOTE**

- Dip the seal rubber to facilitate installation.
- Check that the seal rubber is positioned properly.

Slide the collar into the impeller and install the impeller.

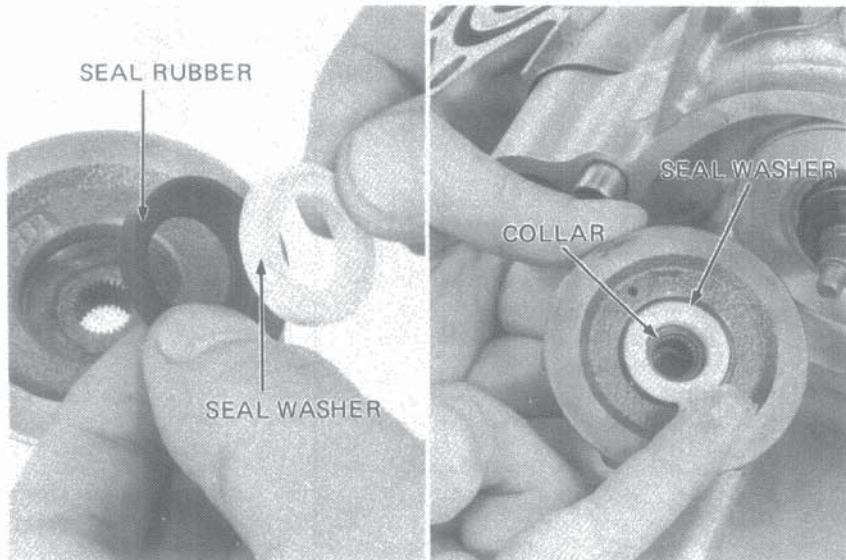

Install the copper washer and cap nut on the camshaft and torque the cap nut.

**TORQUE: 0.8–1.2 kg-m**

**(6–9 ft-lbs, 52–104 in-lbs)**

Rotate the crankshaft to make sure that the pump turns freely without binding.

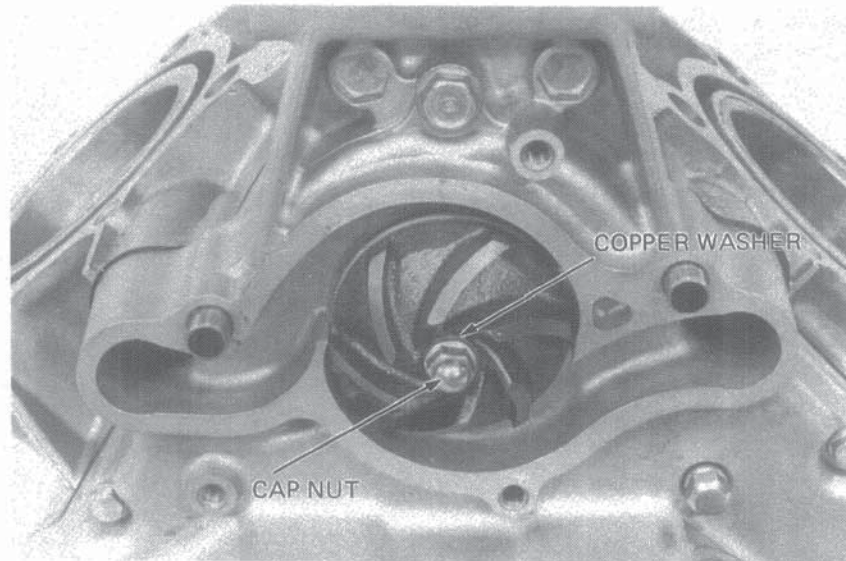

Place a gasket on the water pump cover and install the cover.

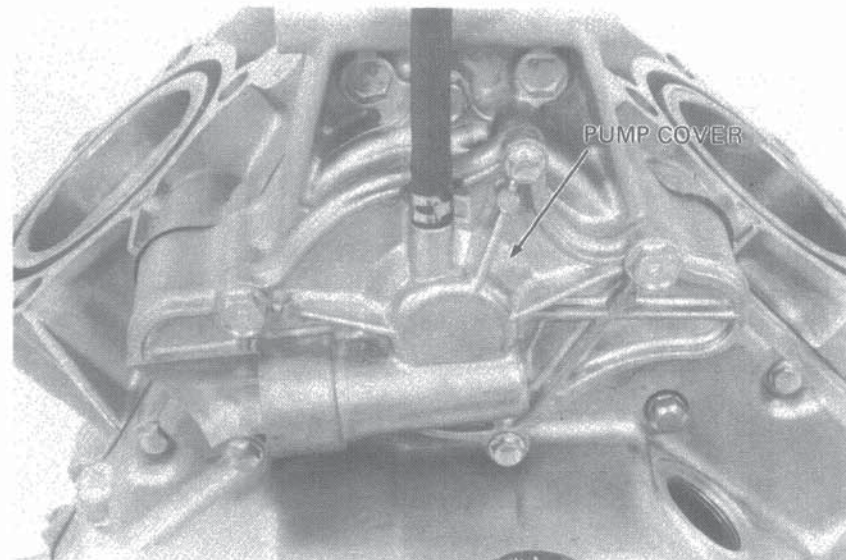





Slip on the O-ring on the water pipe and press the water pipe into place in the pump rear cover.

### NOTE

Make sure that the O-ring is properly seated.

Install the water pipe holders.

### NOTE

Torque the upper bolts ① first, then torque the lower bolts ②.

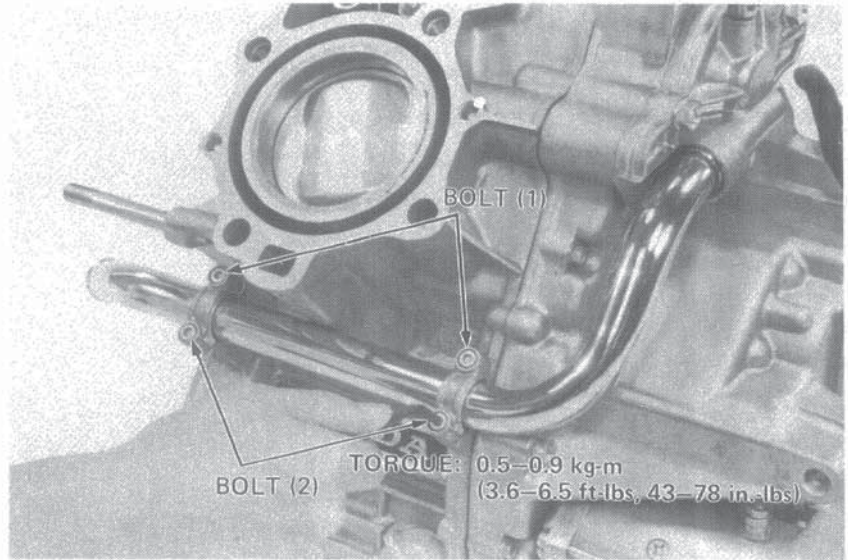

## THERMOSTAT INSTALLATION

Insert the thermostat into the thermostat case. Install a new O-ring on the thermostat case and attach the thermostat cover and bracket. Install the temperature unit, slide new O-rings onto the water pipes, press the water pipes into the thermostat case and elbows.

### NOTE

Check that the O-rings are not dislodged.

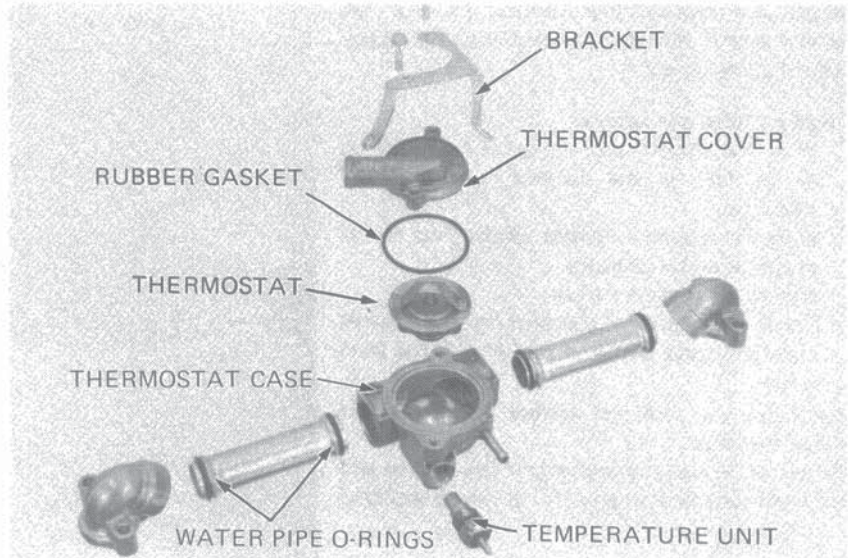

Install the thermostat assembly.  
Install the air spoiler.  
Connect the water bypass hose.

## COOLING FAN INSTALLATION

Install the cooling fan.  
Install the radiator.  
Install the air spoiler.

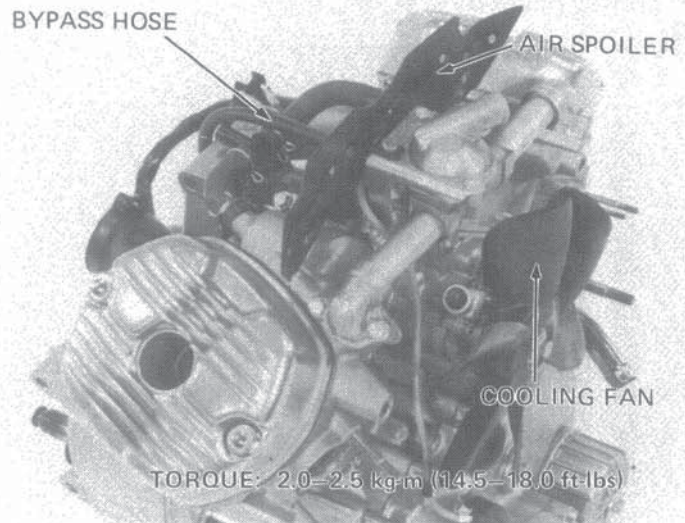





## RADIATOR INSTALLATION

Torque the radiator drain bolt.

**TORQUE: 0.15–0.30 kg-m (13–26 in-lbs)**

Install the radiator upper and under hoses on the thermostat cover and water pipe.

Tighten the radiator mount bolts (6 mm).  
Tighten the radiator upper and under hose bands.

Install the radiator cover.

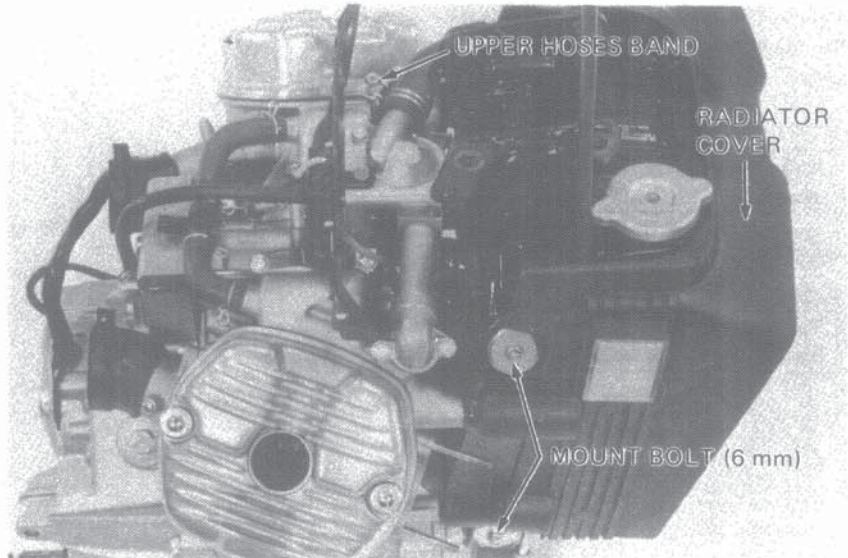

Install the engine (See Section 5). Fill the system with a 50–50 mixture of distilled water and ethylene glycol.

Bleed air from the radiator

- Start the engine and run until there are no air bubbles in the coolant, and the level stabilizes.
- Stop the engine and add coolant up to the proper level if necessary.
- Reinstall the radiator cap.
- Check the level of coolant in the reserve tank and raise to the correct level if the level is low.

Pressurize the radiator, engine and hoses and check for leaks.

Repair or replace components if the system will not hold specified pressure for at least 6 seconds.

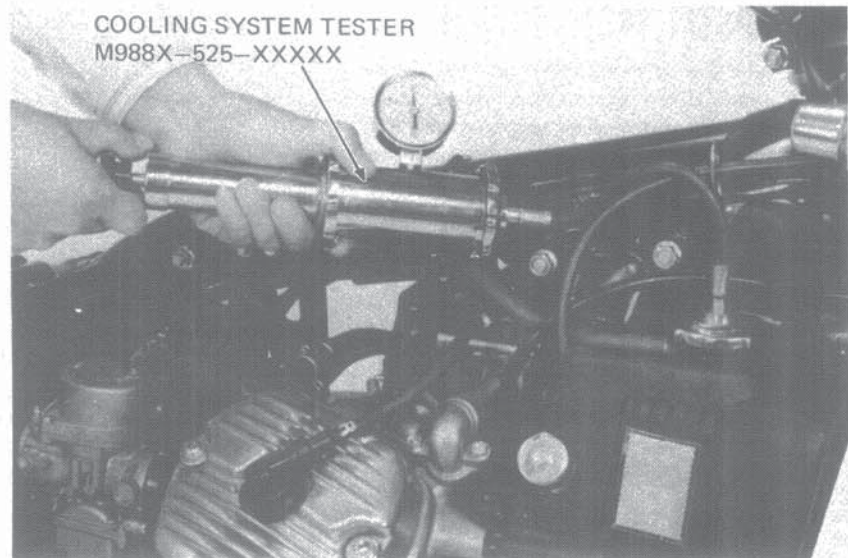

### CAUTION

*Excessive pressure can damage the radiator. Do not exceed 1.05 kg/cm<sup>2</sup> (14.9 psi).*

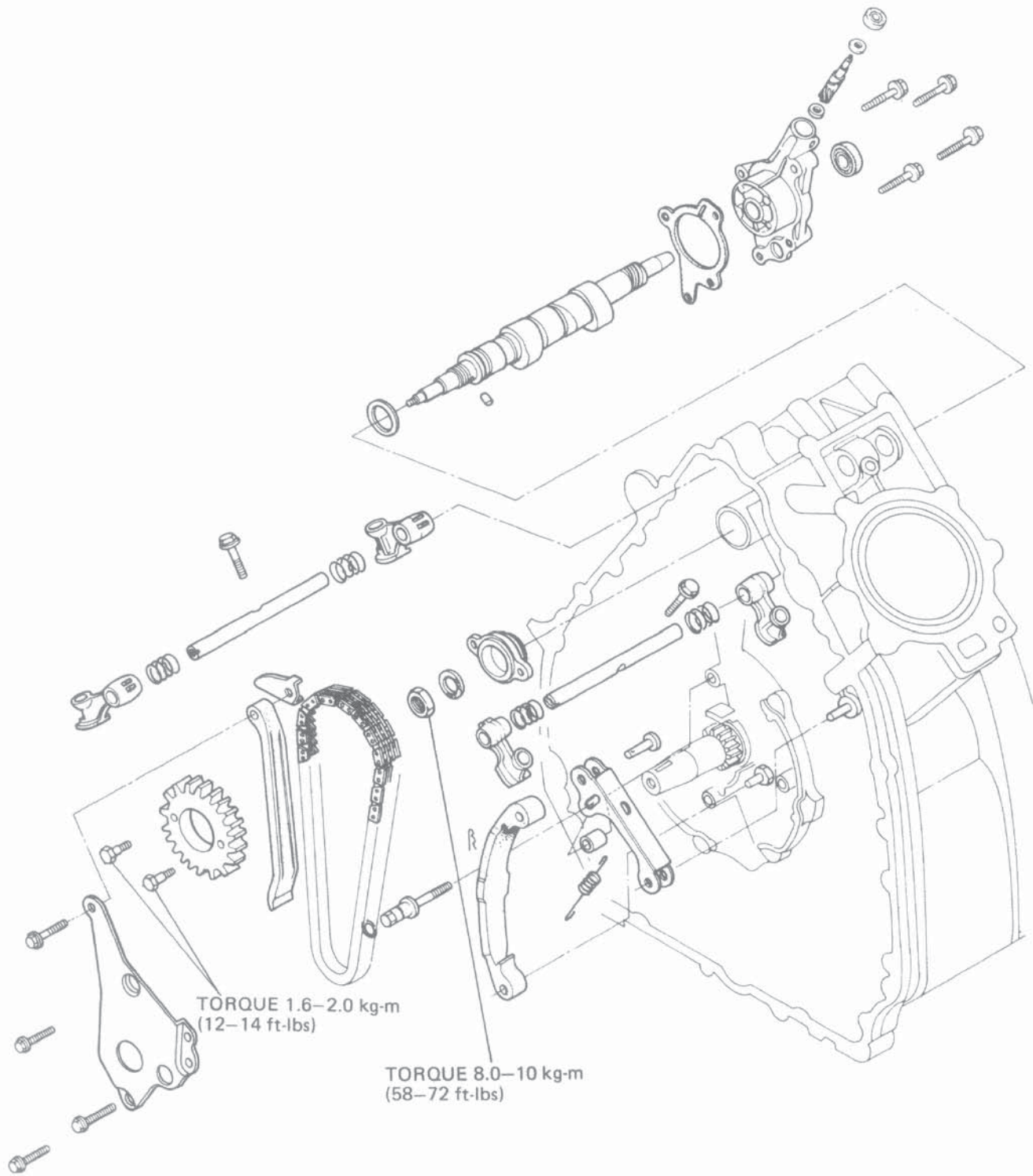





SERVICE INFORMATION	10-1
TROUBLESHOOTING	10-1
CAM CHAIN REMOVAL	10-2
CAMSHAFT REMOVAL	10-2
ROCKER ARM REMOVAL	10-5
ROCKER ARM INSTALLATION	10-6
CAMSHAFT INSTALLATION	10-7
VALVE TIMING ADJUSTMENT	10-9

## SERVICE INFORMATION

### • WORKING PRACTICE

Camshaft lubricating oil is fed from the oil filter to the front bearing through an oil control orifice located in the engine case, and to the rear bearing through an oil control orifice in the camshaft rear holder.

Be sure these orifices are not clogged and that the O-rings and dowel pins are in place before assembling the engine.

Before assembling the camshaft, lubricate the bearings with engine oil and pour 100 cc of engine oil into the engine block oil pockets to provide initial lubrication.

### • SPECIAL TOOLS

- GEAR HOLDER 07924-4150000
- LOCK NUT SOCKET WRENCH (17 x 27 mm) 07907-4150000

### • SPECIFICATIONS

			Standard	Service Limit
Camshaft	Cam lift	IN	37.046 mm (1.4585 in.)	36.058 mm (1.4196 in.)
		EX	37.015 mm (1.4573 in.)	36.027 mm (1.4184 in.)
	Journal O.D.	Front	21.959-21.980 mm (0.8645-0.8654 in.)	21.910 mm (0.8526 in.)
		Rear	25.959-26.980 mm (1.0220-1.0622 in.)	25.910 mm (1.0201 in.)
Rocker arms and shafts	Arm I.D.		14.016-14.027 mm (0.5518-0.5522 in.)	14.046 mm (0.5530 in.)
	Shaft O.D.		13.982-14.000 mm (0.5505-0.5512 in.)	13.966 mm (0.5510 in.)
	Camshaft holder I.D.		22.000-22.021 mm (0.8661-0.8670 in.)	22.050 mm (0.8681 in.)
	Camshaft block journal I.D.		26.000-26.021 mm (1.0236-1.0244 in.)	26.170 mm (1.0303 in.)

## TROUBLESHOOTING

### Excessive Noise

1. Incorrect cam chain adjustment
2. Incorrect valve adjustment
3. Worn or damaged rocker arms or camshaft
4. Worn or damaged cam chain tensioner or cam chain guide
5. Worn cam sprocket teeth
6. Worn camshaft holder



**CAMSHAFT/CAM CHAIN**

**CAM CHAIN REMOVAL**

Remove the flywheel. (Page 8-4).  
Remove the chain guide set plate B bolts.  
Remove the chain guide set plate B with spring from the crank shaft.  
Free the chain guide set plate from the spring.

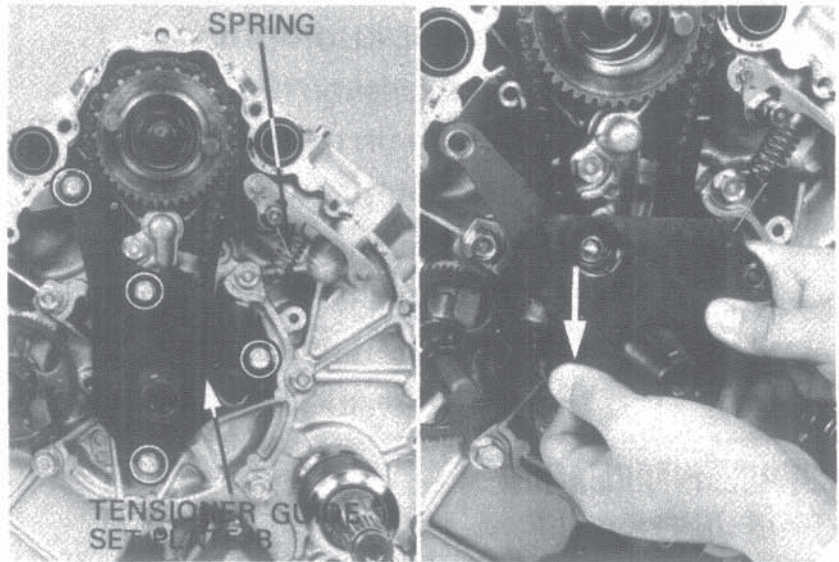

Remove the lock bolt and collar.  
Remove the tensioner, cam chain guide and chain guide set plate A.  
Remove the tensioner and cam chain guide.  
Remove the 7 mm dowel bolts and remove the cam sprocket and cam chain.

Check the cam chain guide and tensioner for wear or damage to the slipper surfaces.

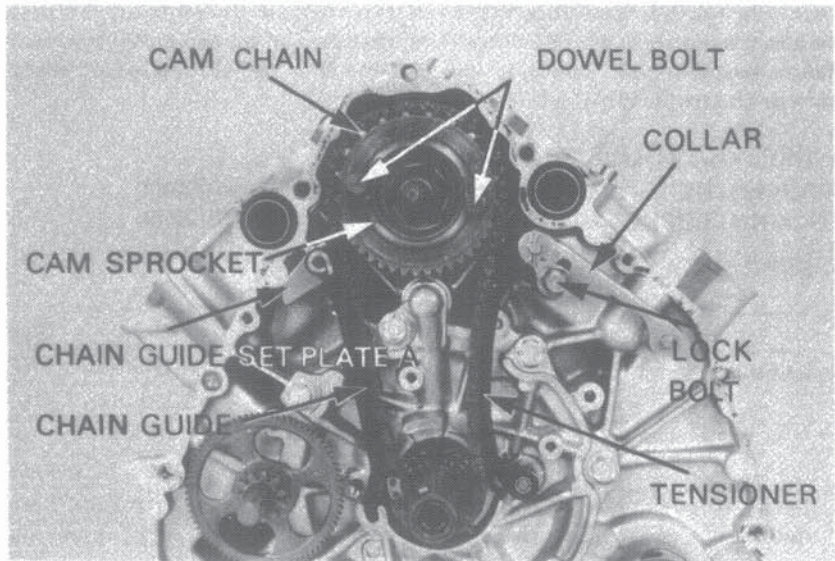

**CAMSHAFT REMOVAL**

Temporarily install the cam sprocket.  
Hold the cam sprocket with a GEAR HOLDER to prevent it from turning.  
Loosen the 27 mm nut and remove the cam sprocket and cam sprocket boss.

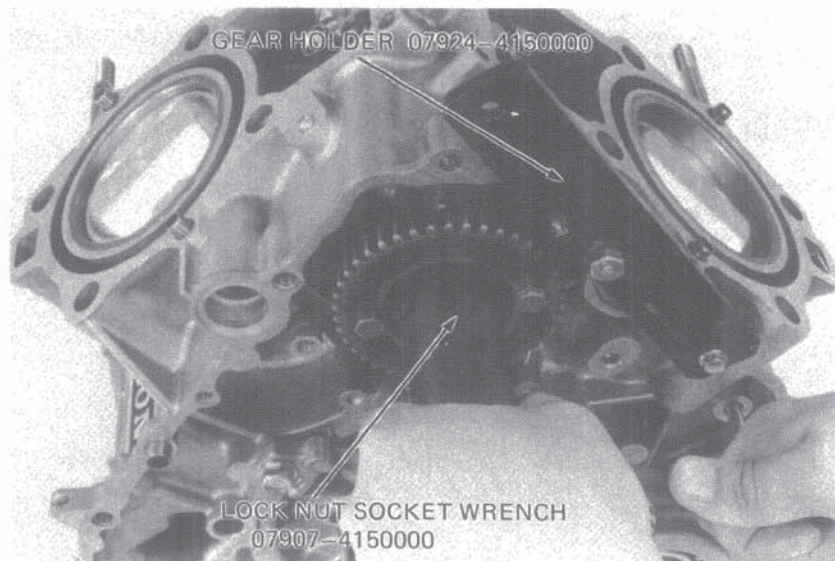





Remove the cooling fan (Page 9-5).  
Remove the camshaft holder.

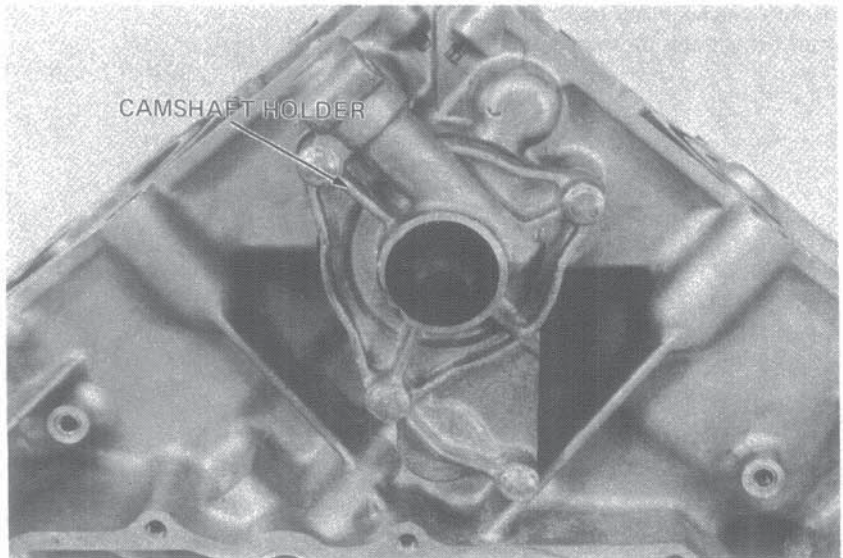

Remove the camshaft from the front.

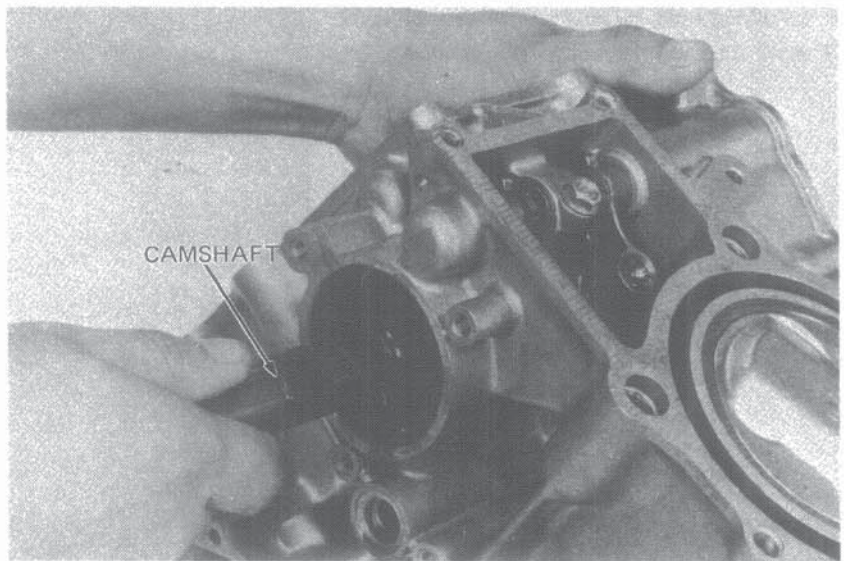

● **CAMSHAFT INSPECTION**

Measure the O.D. of each camshaft bearing journal.

Calculate the journal and bearing clearance.

**SERVICE LIMIT: 0.260 mm (0.0102 in.)**

Inspect the worn gear for wear or damage.

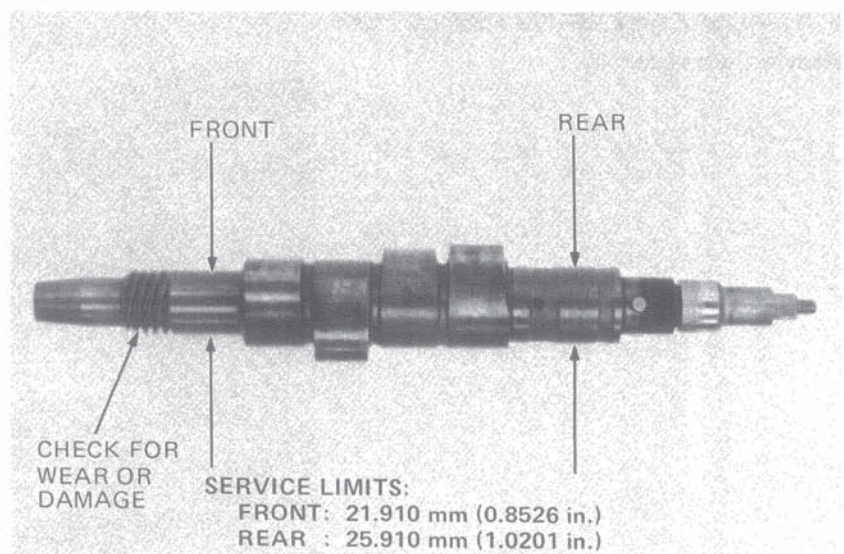





**CAMSHAFT/CAM CHAIN**

Measure the height of each cam lobe.  
Inspect the lobes for wear or damage.

**SERVICE LIMITS:**

IN : 36.058 mm (1.4196 in.)  
EX : 36.027 mm (1.4184 in.)

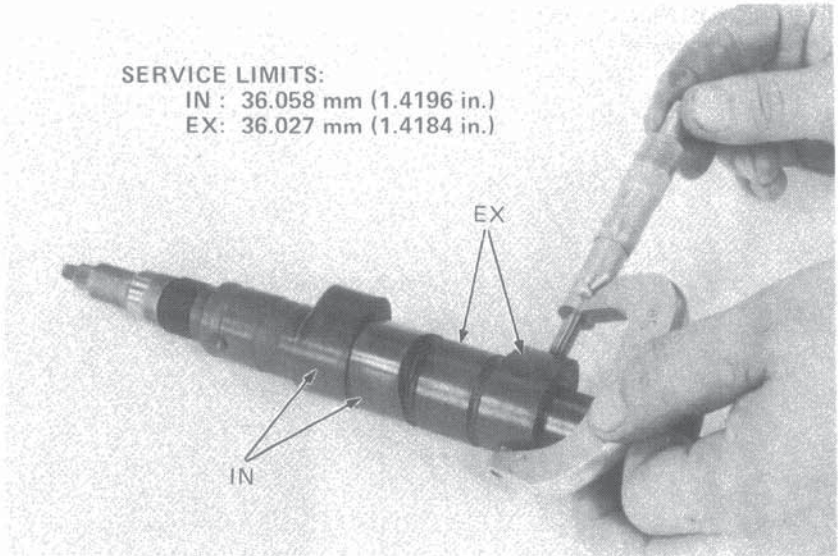

● **CAMSHAFT HOLDER INSPECTION**

Measure the camshaft holder I.D. as shown.

**SERVICE LIMIT: 22.050 mm (0.8681 in.)**

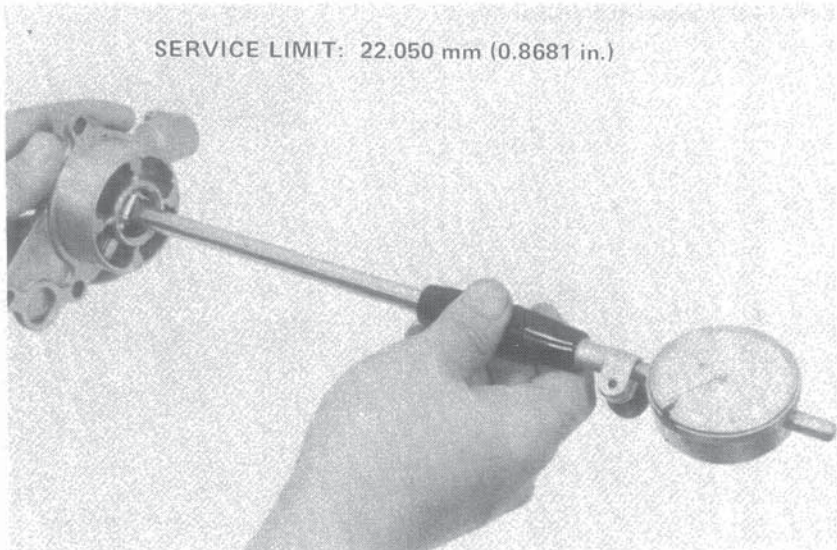

● **CAMSHAFT BEARING INSPECTION**

Measure the bearing I.D.

**SERVICE LIMIT: 26.170 mm (1.0303 in.)**

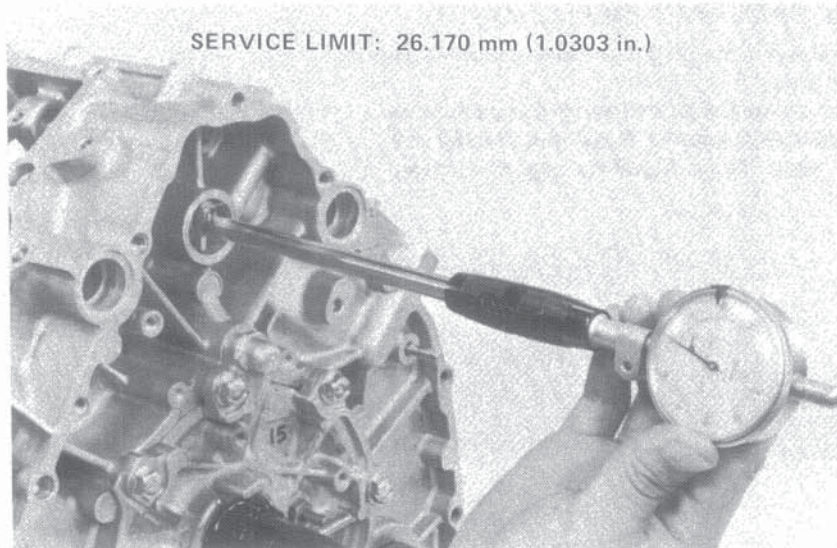





## ROCKER ARM REMOVAL

Remove the rocker arm shaft bolts.

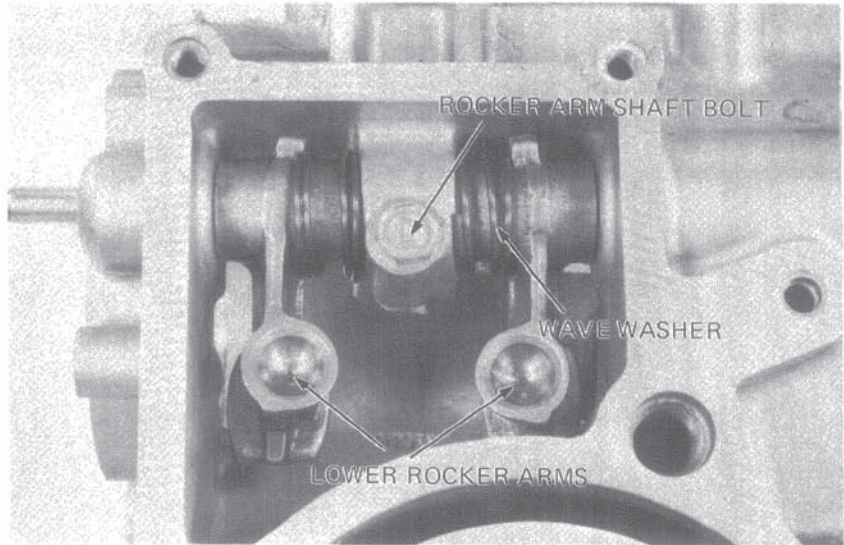

Screw a 6 mm bolt into the rocker arm shaft.  
Remove the rocker arm shaft.  
Remove the rocker arm and wave washer.

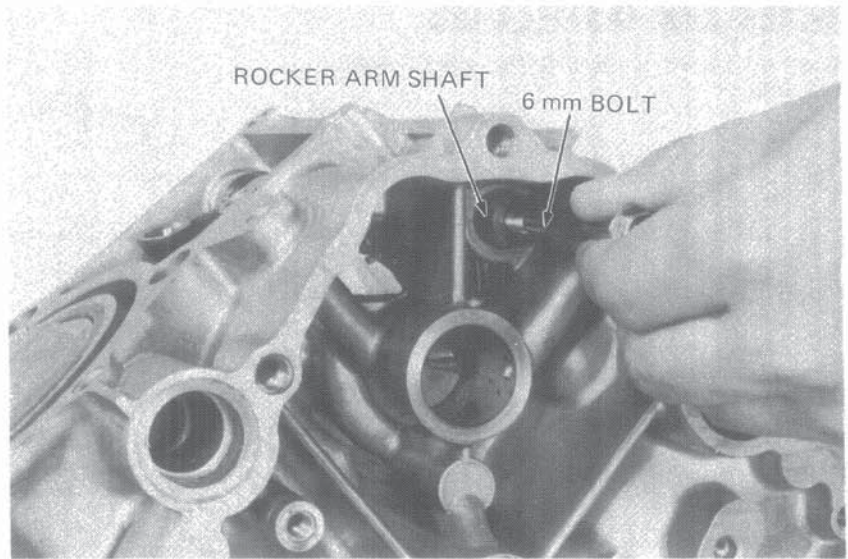

### • ROCKER ARM INSPECTION

Inspect the rocker arms for wear or damage to the camshaft contact surfaces, or clogged oil holes.

Measure the I.D. of each rocker arm.

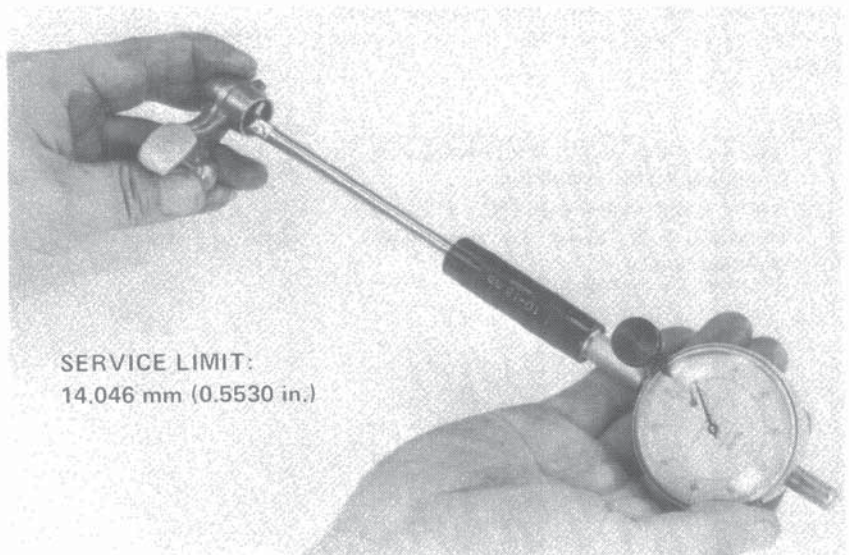





**CAMSHAFT/CAM CHAIN**

• **ROCKER ARM SHAFT INSPECTION**

Measure each rocker arm shaft O.D.  
Inspect the shaft for wear damage.  
Calculate the clearance of the shaft and the  
rocker arm.

**SERVICE LIMIT: 0.08 mm (0.0031 in.)**

**SERVICE LIMIT: 13.966 mm (0.5510 in.)**

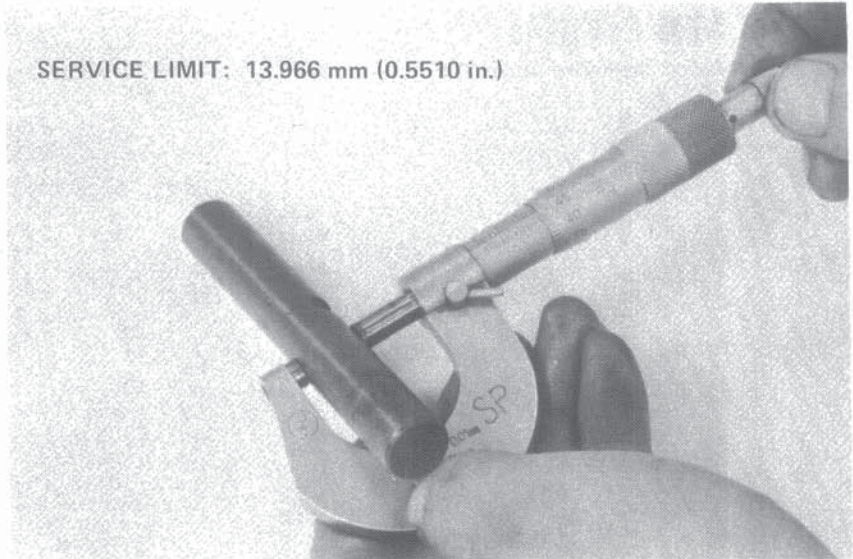

**ROCKER ARM INSTALLATION**

Install the rocker arms with the offset toward  
the inside.

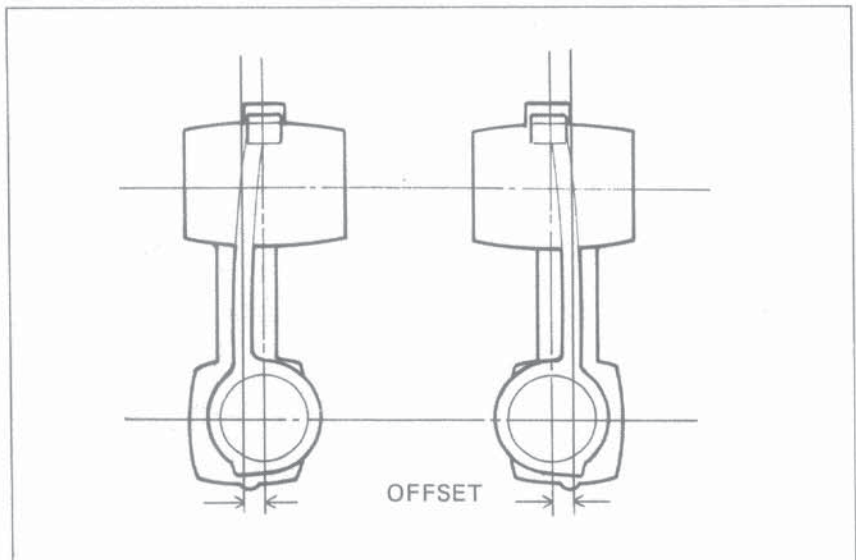

Install the rocker arms and thrust springs in the  
cylinder block, and then insert the rocker arm  
shafts.

**NOTE**

- Lubricate the rocker arm shafts with engine oil before installation.
- Install each rocker arm shaft with the threaded end facing the rear (cam sprocket side).

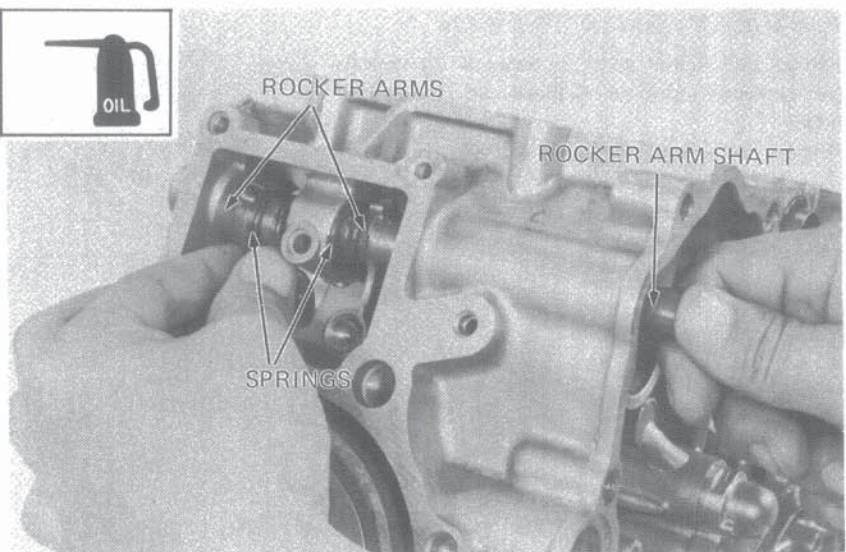





Rotate the rocker arm shaft with a screwdriver to align with the lock bolt hole. Install the lock bolt.

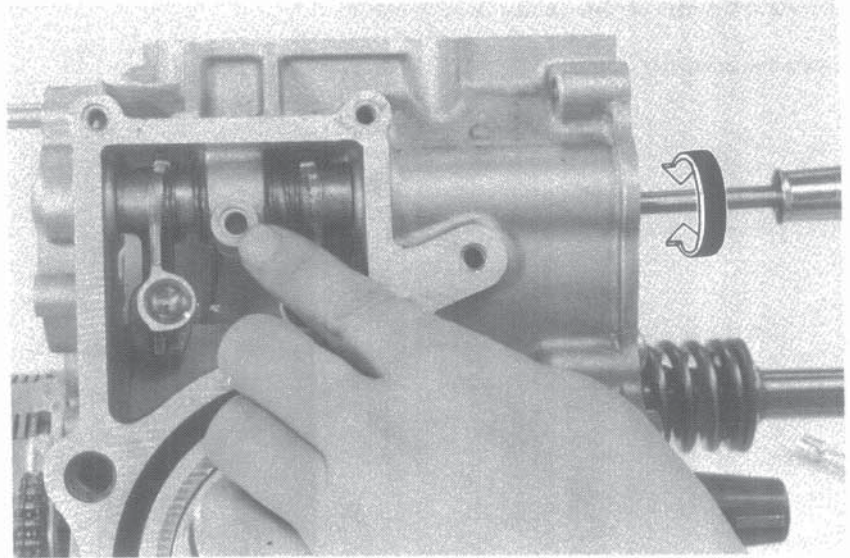

### **CAMSHAFT INSTALLATION**

Lubricate the camshaft journals with molybdenum disulfide grease.  
Install the camshaft thrust washer.  
Insert the camshaft from the front.

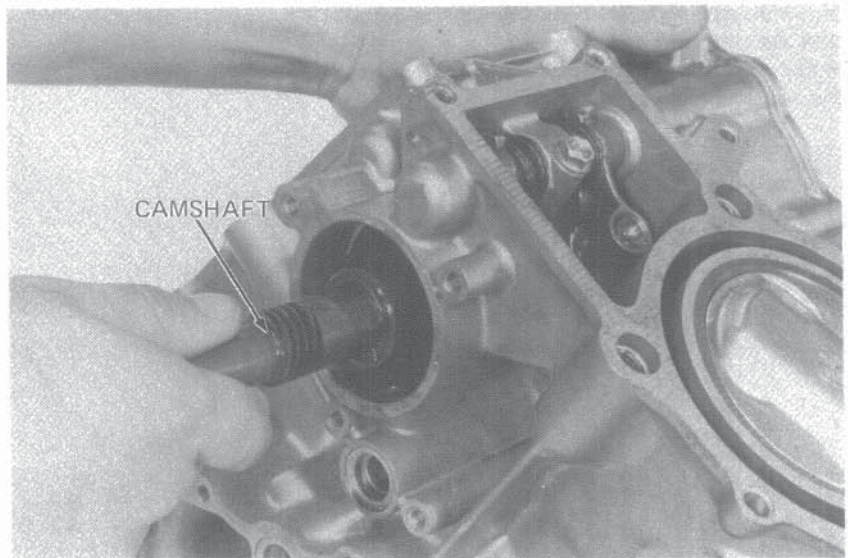

Install the camshaft holder gasket, O-ring, and collar.

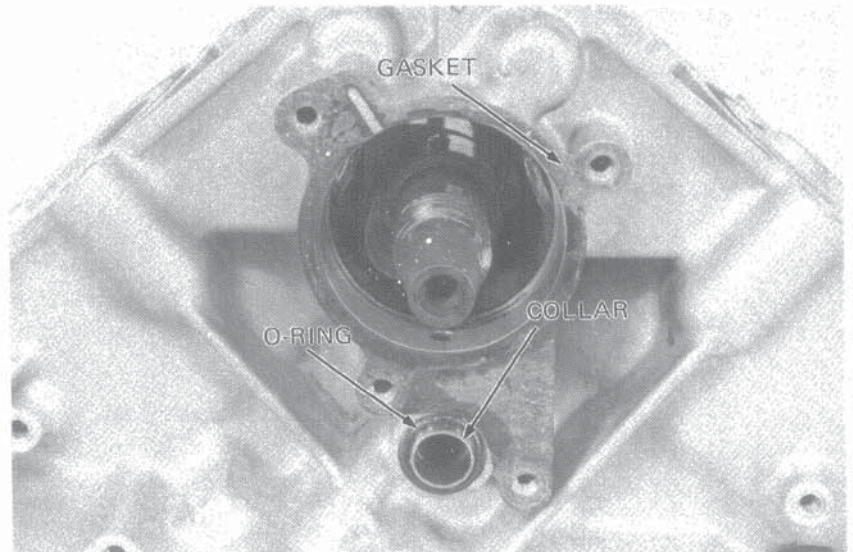





Lubricate the cam holder oil seal lip with engine oil.

Install the camshaft holder.

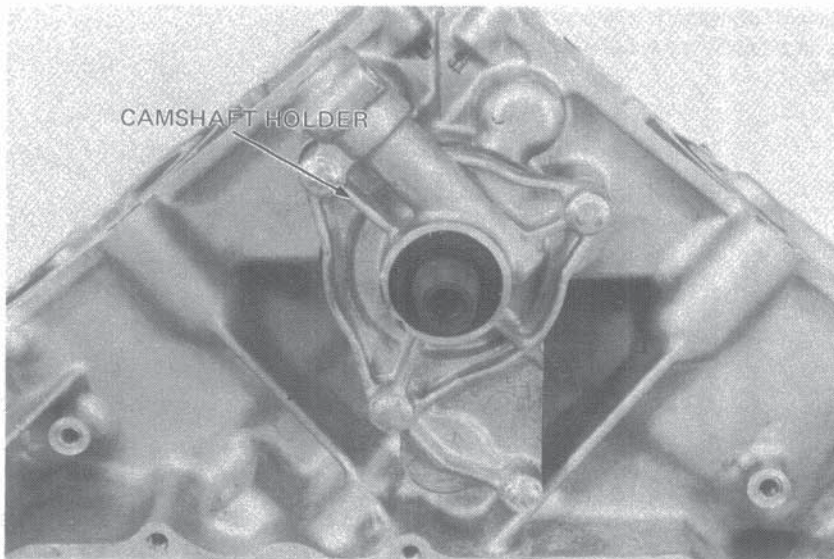

Install the cam sprocket boss aligning the cutout with the camshaft dowel pin.

Install the lock nut and lock washer and tighten the nut temporarily.

**NOTE**

Install the lock washer with the mark "OUTSIDE" facing out.

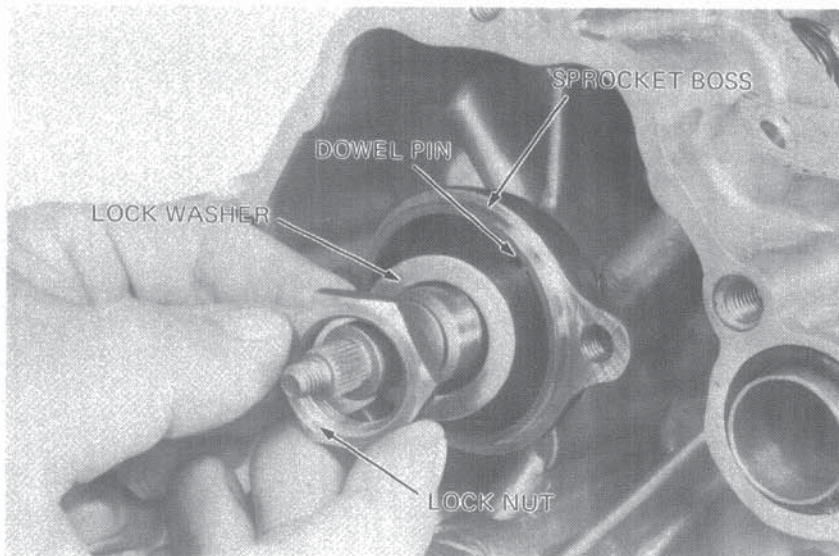

Install the cam sprocket and finger tighten the bolts.

Hold the cam sprocket with the GEAR HOLDER.

Torque the lock nut.

Remove the cam sprocket.

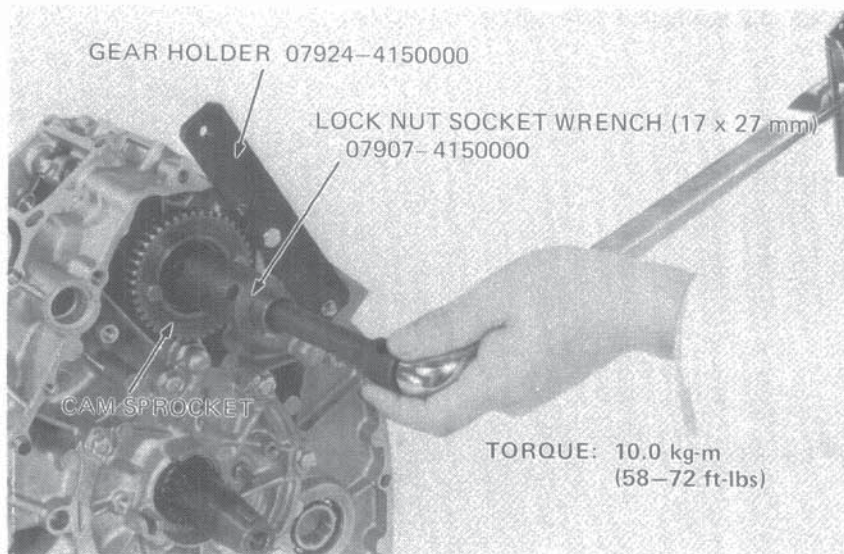





## VALVE TIMING ADJUSTMENT

Align the holes in the cam sprocket boss with the aligning marks on the cylinder block.

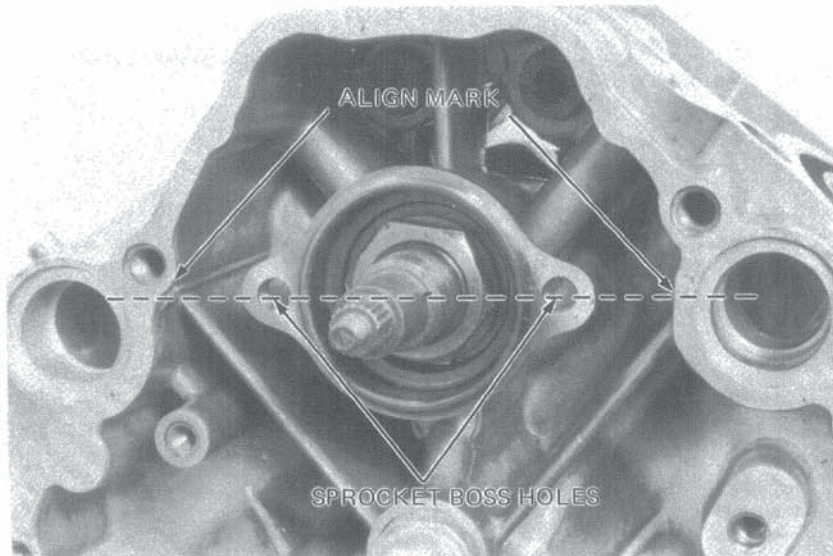

Rotate the crankshaft to bring the left piston to TDC.

Verify the valve timing by observing the following:

- Make sure the cam sprocket bolts are in line with the aligning marks on the cylinder block.
- Check that the flywheel woodruff key aligns with the index mark on the crankshaft cap.

### NOTE

When inspecting the valve timing, push the cam chain from the right side so the tensioner-side of the chain is pulled taut.

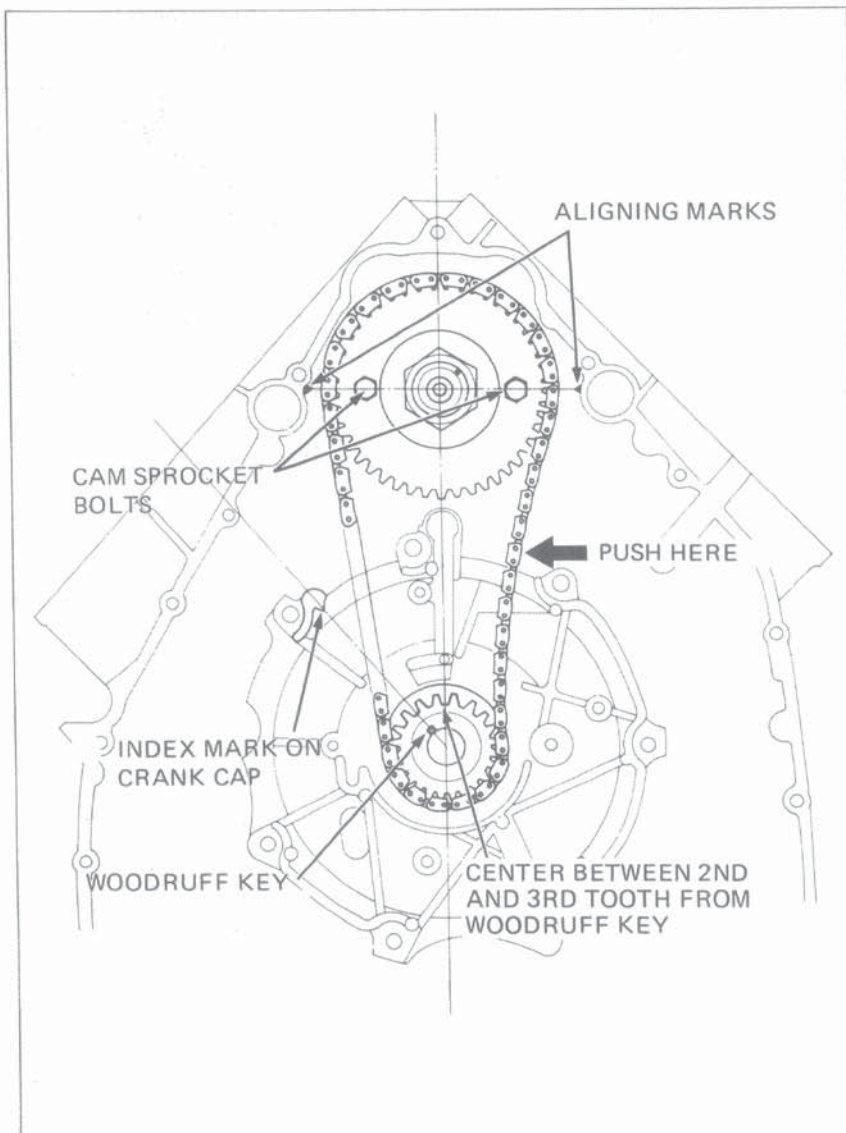





**CAMSHAFT/CAM CHAIN**

Hold the camshaft with the LOCK NUT SOCKET WRENCH.  
Torque the cam sprocket bolts.

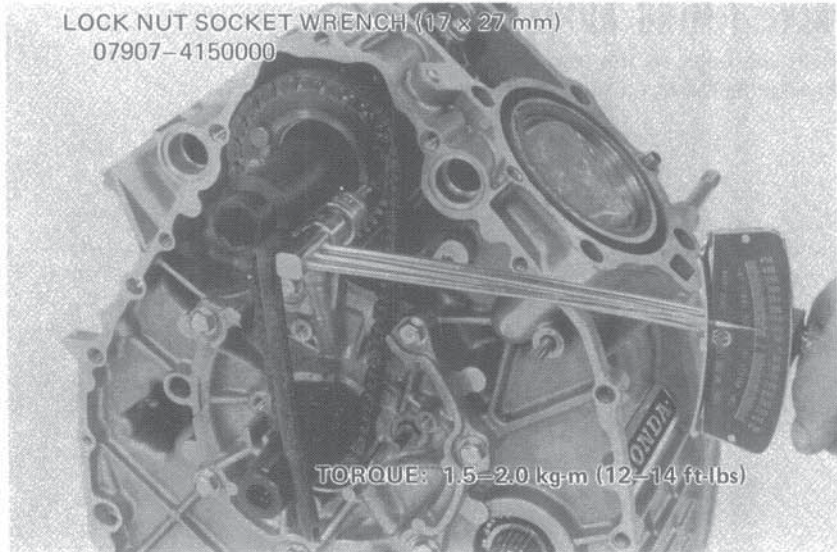

Install the chain guide set plate A, cam chain guide and cam chain tensioner.  
Install the tensioner spring.  
Install the O-ring on the lock nut.  
Slide the collar into the tensioner arm and install the lock bolt. Do not tighten the lock bolt at this time.

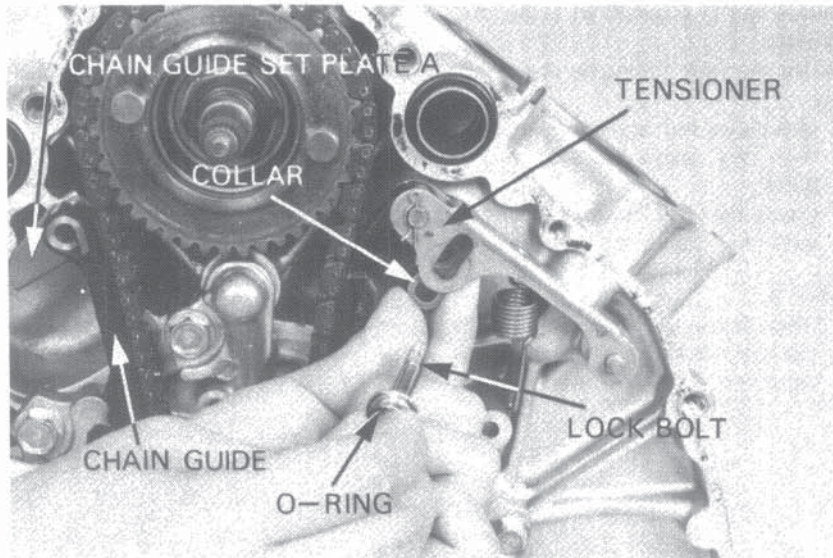

Hook the spring on the chain guide set plate B and install the set plate B.  
Tighten the 6 mm bolt.  
Tighten the lock bolt.

TORQUE: 0.8-1.2 kg-m (6-9 ft-lb)

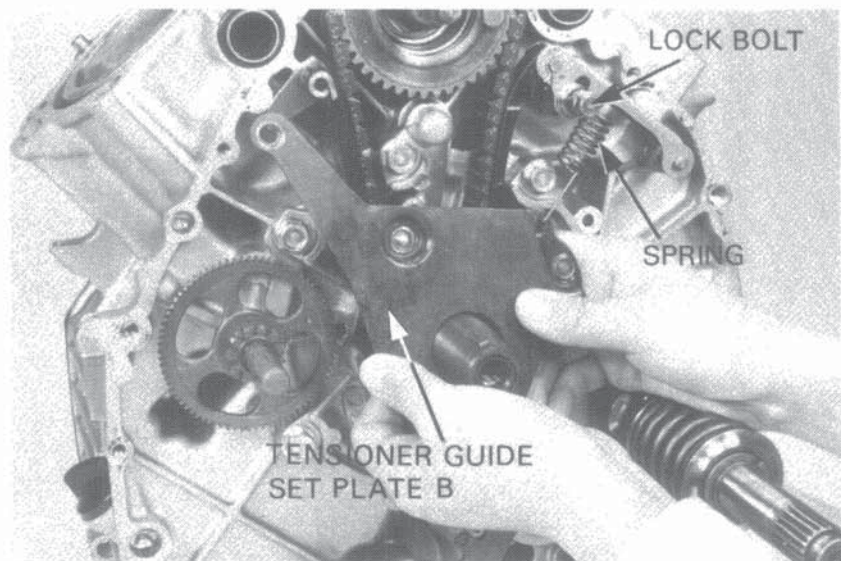





Pour about 100 cc of engine oil into the oil pockets of the cylinder block.  
Install the flywheel (Page 8-7).  
Install the cylinder head (Page 6-14).  
Adjust the valve clearance (Page 3-4).  
Install the engine (See section 5).

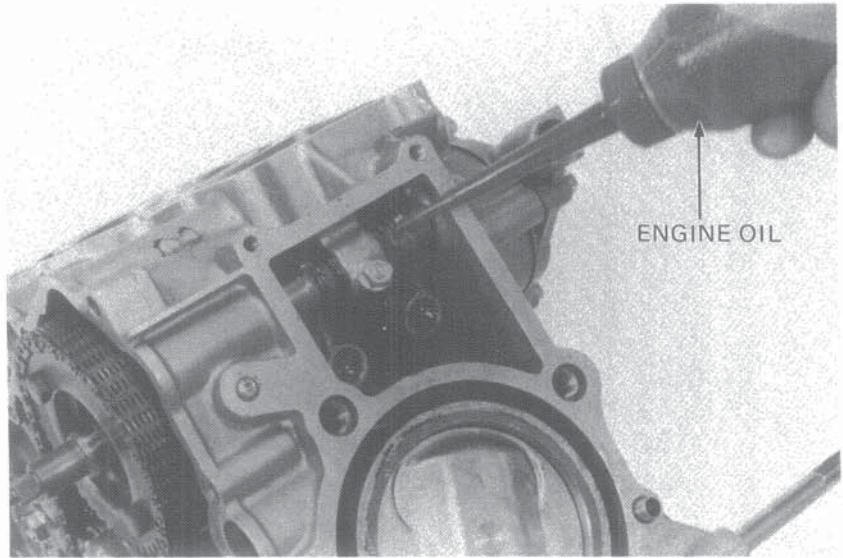



TRANSMISSION

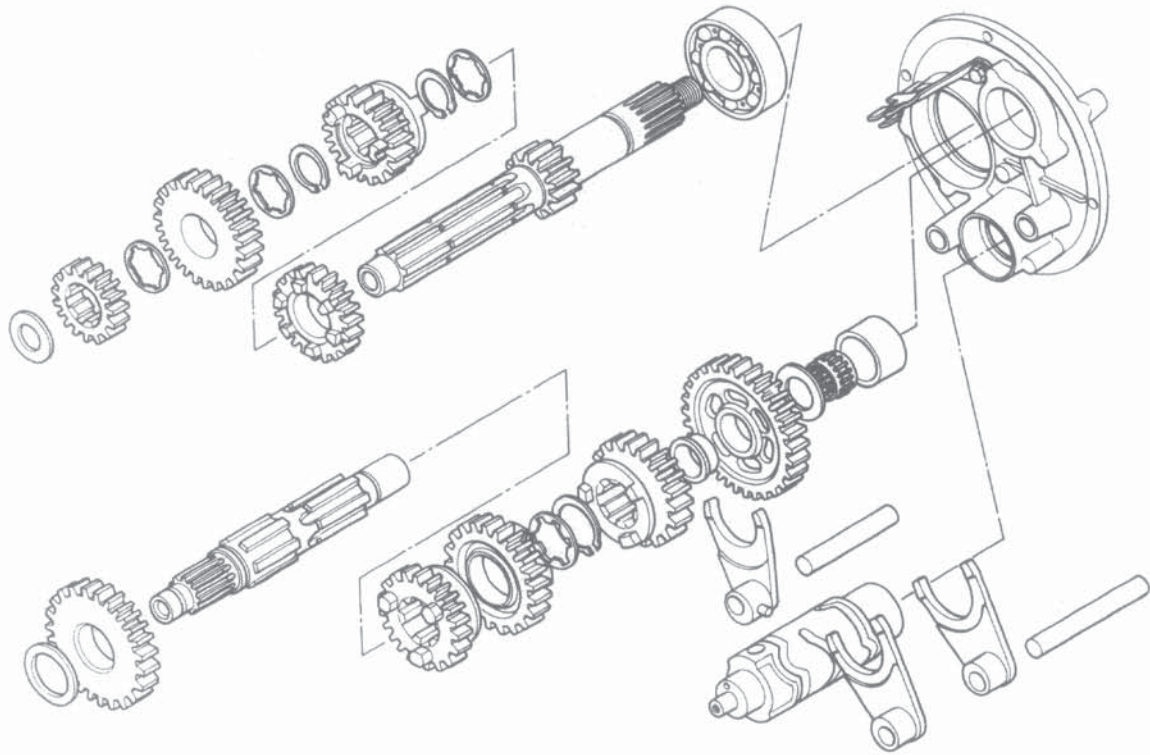





SERVICE INFORMATION	11-1
TROUBLESHOOTING	11-2
GEARSHIFT LINKAGE REMOVAL	11-3
FINAL SHAFT DISASSEMBLY	11-3
FINAL SHAFT ASSEMBLY	11-4
TRANSMISSION DISASSEMBLY	11-4
TRANSMISSION ASSEMBLY	11-10
GEARSHIFT LINKAGE INSTALLATION	11-13

## SERVICE INFORMATION

- WORKING PRACTICE

Before reassembling, lubricate the M4 and M5 gears with molybdenum disulfide grease (MOLYCOAT 321) or an equivalent. Apply engine oil to the other gears.

- SPECIAL TOOLS

Special tools

CRANK CAP DRIVER (for damper spring compressor)	07945-4150100
BEARING REMOVER (20 mm)	07936-3710600
BEARING REMOVER HANDLE	07936-3710100
BEARING REMOVER WEIGHT	07936-3710200
BEARING DRIVER ATTACHMENT	07945-3330100
BEARING DRIVER HANDLE	07949-6110000
BEARING DRIVER ATTACHMENT	07946-3600000
BEARING DRIVER ATTACHMENT	07946-3710200
BEARING DRIVER HANDLE	07947-3710000
BALL RACE REMOVER/DRIVER	07946-3290200

Common tools

BEARING DRIVER (42 x 47 mm)	07746-0010300
BEARING DRIVER PILOT (20 mm)	07746-0040500
BEARING DRIVER HANDLE (A)	07749-0010000
BEARING DRIVER (52 x 55 mm)	07746-0010400
BEARING DRIVER PILOT (25 mm)	07746-0040600



● SPECIFICATIONS

Unit: mm (in.)

Item		Standard		Service Limit		
Transmission	M2, M3, M4 and M5 gear I.D.	25.020–25.041	(0.9850–0.9859)	25.10	(0.988)	
	C1 gear I.D.	24.020–24.041	(0.9457–0.9465)	24.10	(0.949)	
	C2 gear I.D.	27.520–27.541	(1.0835–1.0843)	27.60	(1.087)	
	C3 and C4 gear I.D.	25.020–25.041	(0.9850–0.9859)	25.10	(0.988)	
	C5 gear I.D.	32.000–32.025	(1.2598–1.2608)	32.10	(1.264)	
	C1 gear bushing	I.D.	20.020–20.041	(0.7882–0.7890)	20.06	(0.790)
		O.D.	23.984–24.005	(0.9443–0.9451)	23.95	(0.943)
	Mainshaft O.D.	24.940–24.959	(0.9819–0.9827)	24.91	(0.781)	
	Countershaft O.D.	At C1	19.987–20.000	(0.7869–0.7874)	19.96	(0.786)
		At C2	27.459–27.480	(1.0811–1.0818)	27.43	(1.080)
		At C3 and C4	24.959–24.980	(0.9826–0.9835)	24.93	(0.981)
At C5		31.950–31.975	(1.2579–1.2586)	31.91	(1.256)	
Gear-to-bushing clearance		—		0.15	(0.006)	
Shift drum	O.D.	34.950–34.975	(1.3760–1.3770)	34.90	(1.374)	
	I.D.	35.00 –35.025	(1.3780–1.3789)	35.06	(1.380)	
Shift fork	Claw thickness	5.930 –6.000	(0.233 –0.236)	5.50	(0.217)	
	I.D.	13.000–13.018	(0.5118–0.5125)	13.05	(0.514)	
Fork shaft	O.D.	12.966–12.984	(0.5105–0.5112)	12.95	(0.510)	
Final shaft spring	Free length	73.0	(2.8740)	68.0	(2.677)	

**TROUBLESHOOTING**

Hard to Shift

- Improper clutch adjustment: too much free play
- Shift forks bent
- Shift shaft bent
- Shift fork claw bent
- Shift drum cam grooves damaged
- Shift guide pin damaged

Transmission Jumps Out of Gear

- Gear dogs worn
- Shift shaft bent
- Shift drum stopper broken
- Shift forks bent





### GEARSHIFT LINKAGE REMOVAL

- Remove the transmission cover (Page 7-8).
- Remove the rear cover (page 9-6).
- Remove the rear final shaft.
- Remove the gearshift spindle and shift spring.
- Remove the gearshift arm.

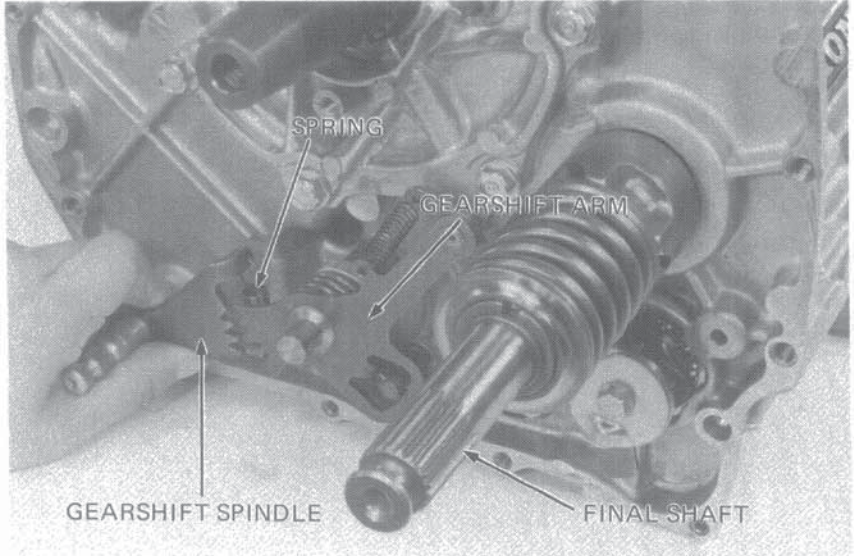

- Remove the shift drum stopper spring.
- Remove the shift drum stopper.
- Remove the neutral switch plate, shift drum stopper plate, gearshift drum pin, and collar.

**NOTE**

Do not disassemble the shift drum plates and pin except when replacement is necessary.

Check all removed parts for wear or damage.

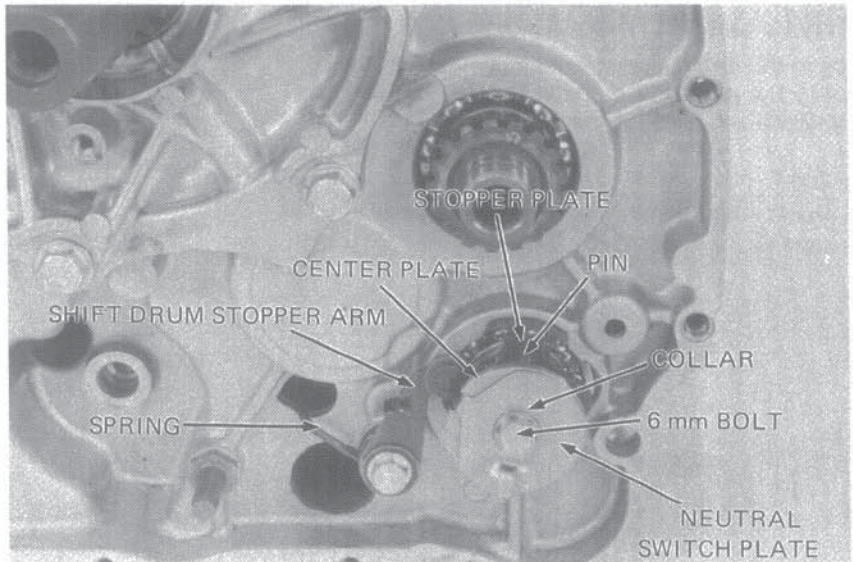

### FINAL SHAFT DISASSEMBLY

- Compress the spring with a press and CRANK CAP DRIVER and remove the spring cotters.
- Remove the spring retainer, damper lifter and cam from the shaft.

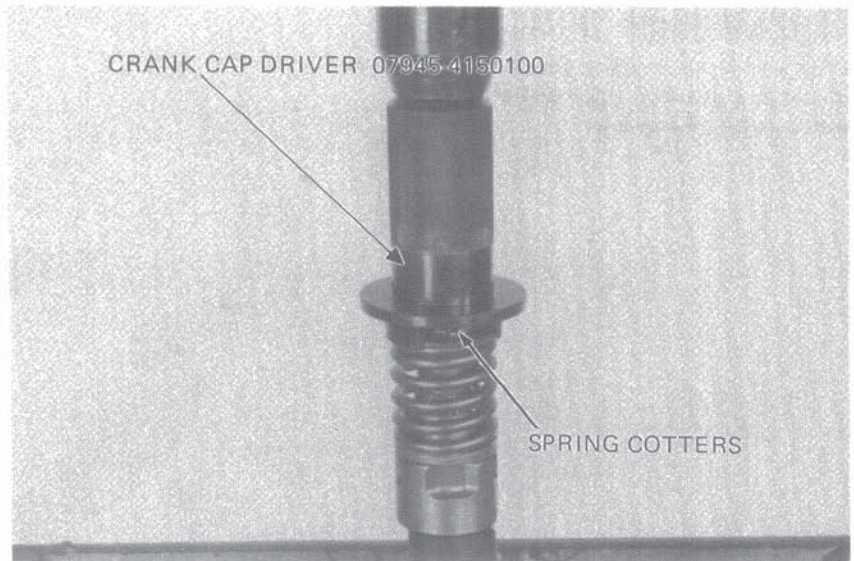





**TRANSMISSION**

Measure the damper spring free length.  
Inspect the damper lifter, shaft, and retainer for wear or damage.

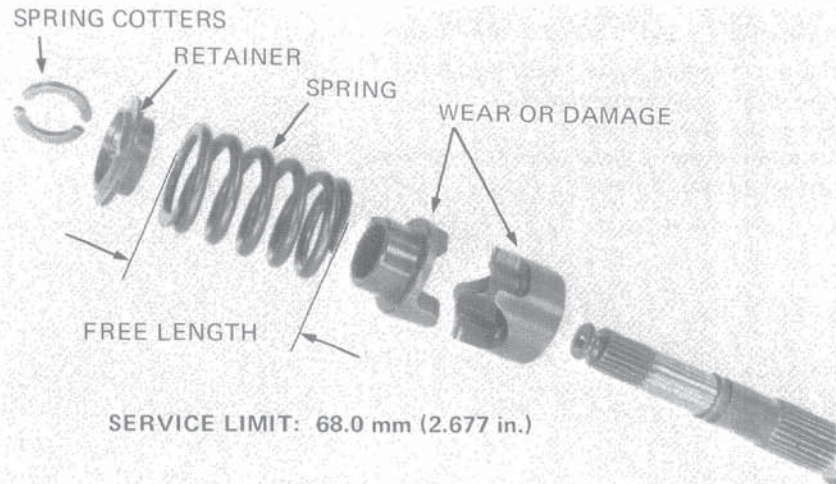

**FINAL SHAFT ASSEMBLY**

Slide the lifter, spring and retainer over the shaft. Compress the spring in the CRANK CAP DRIVER and install the spring cotters.

**NOTE**

Make sure that the cotters are properly seated.

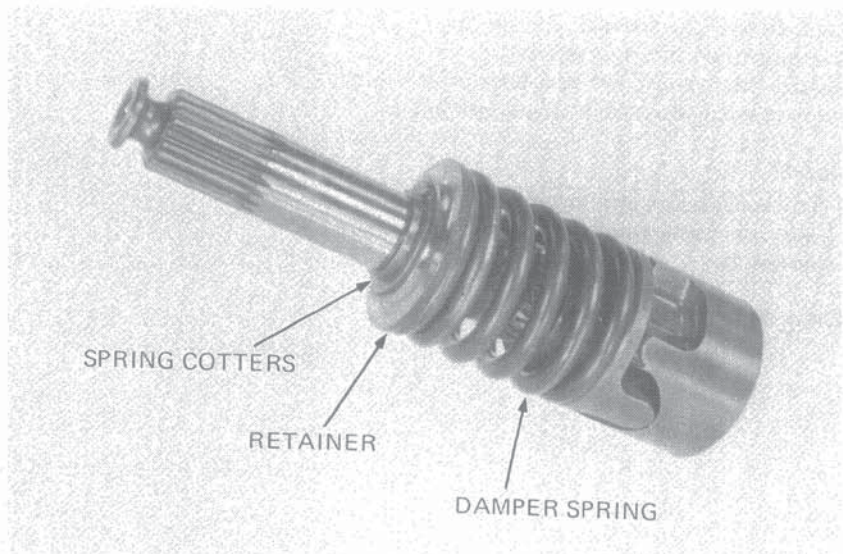

**TRANSMISSION DISASSEMBLY**

Remove the transmission cover and remove the clutch as an assembly (See section 7).  
Remove the oil separator.

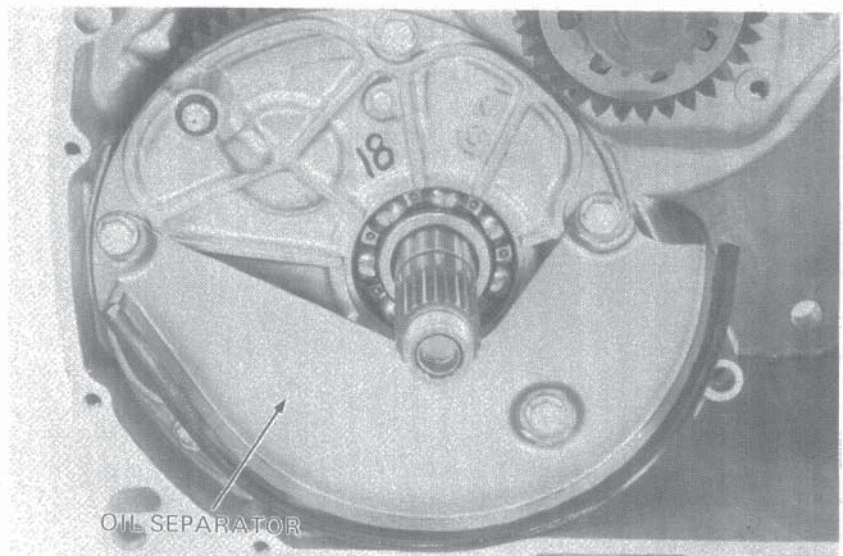





Remove the transmission holder bolts.

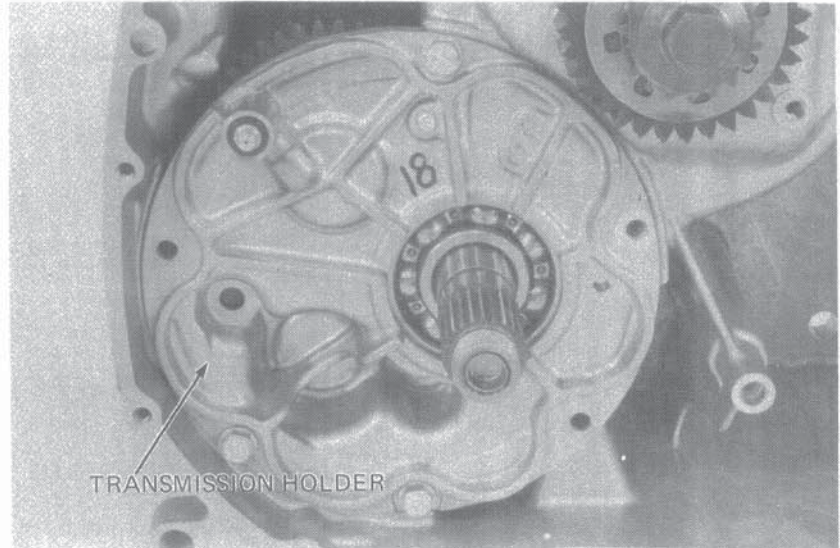

Drive the ends of the countershaft and shift drum carefully and evenly with a soft hammer until the transmission holder is clear of the engine case.

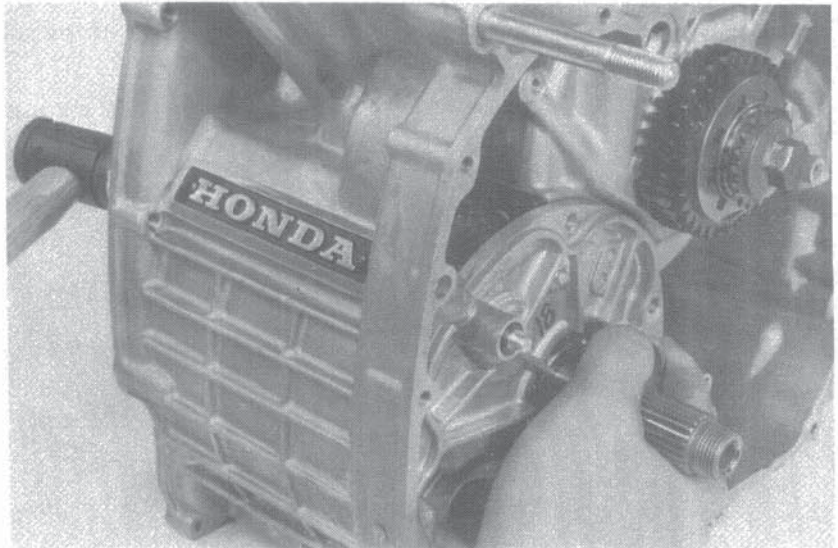

Remove the transmission as shown.

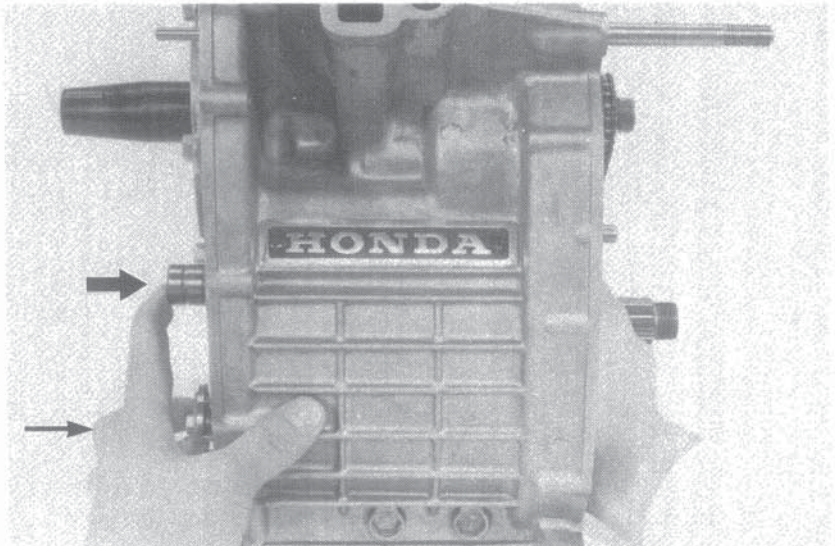



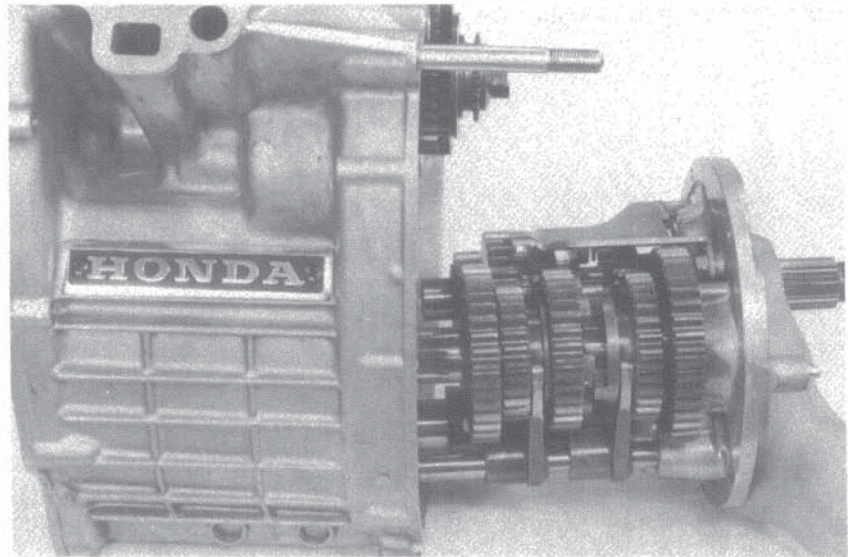

Remove the shift fork shafts.  
Remove the shift forks and the guide pins.  
Remove the shift drum.

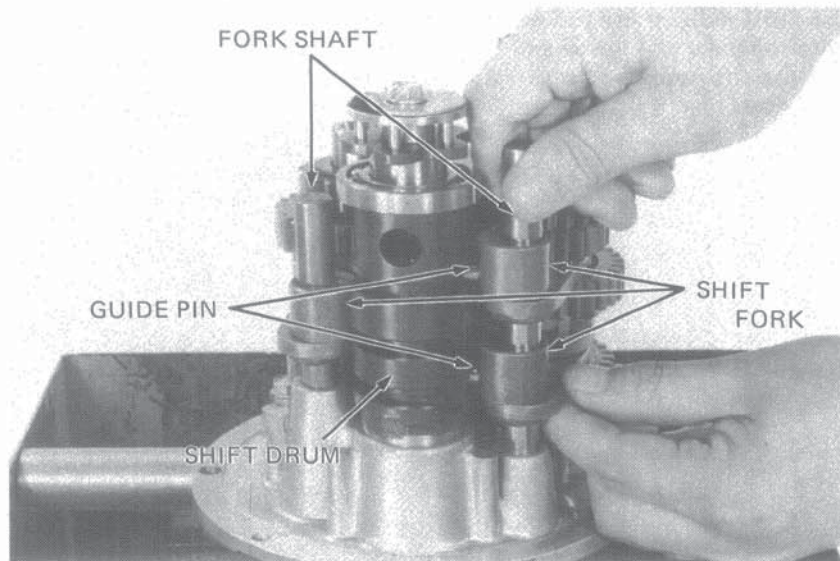

Remove 2nd and 5th gears from the counter-shaft and mainshaft.

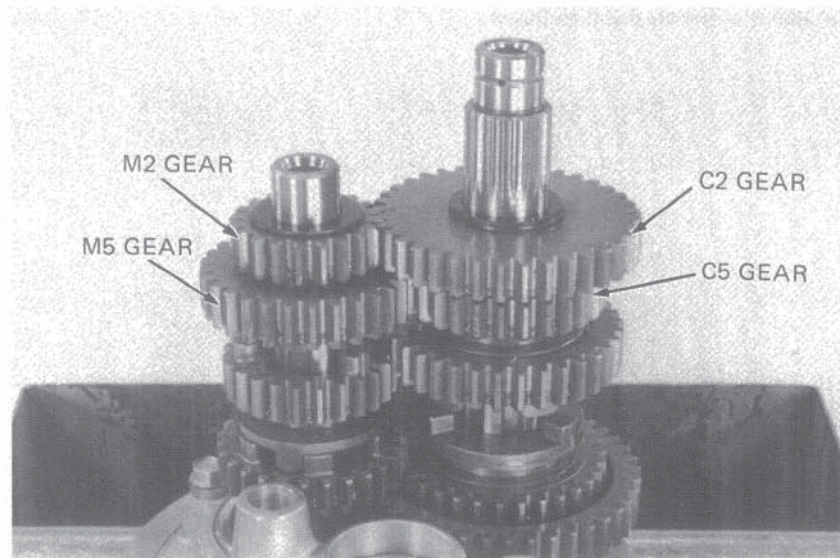





Disassemble the countershaft.

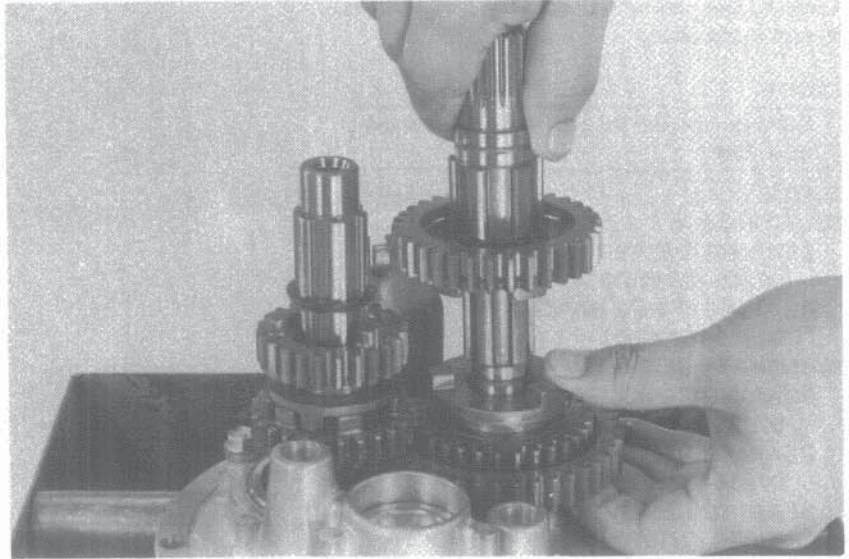

Remove the mainshaft, lightly tapping the end of it with a soft hammer.  
Remove the gears by prying off the snap ring.

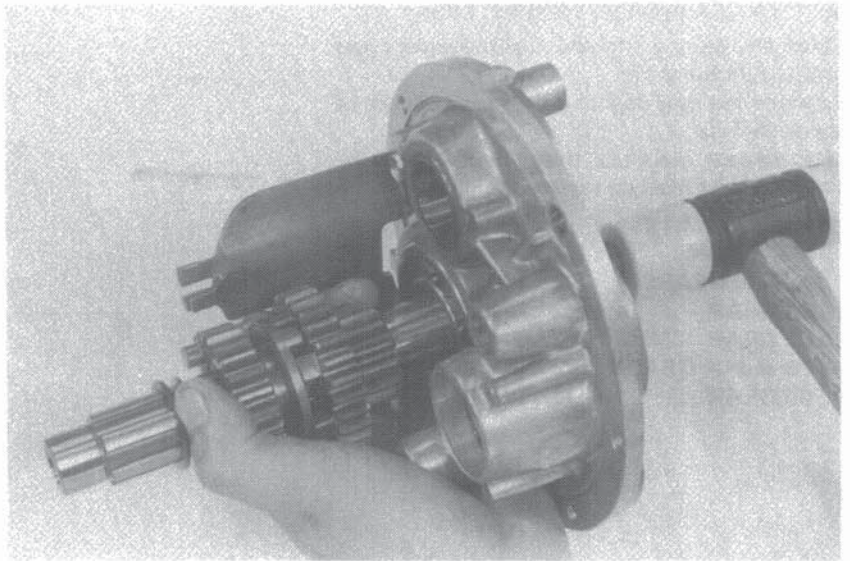

Inspect each holder bearing for wear or damage. They should rotate smoothly and be free of play or rattle.  
Remove the bearings from the transmission holder.

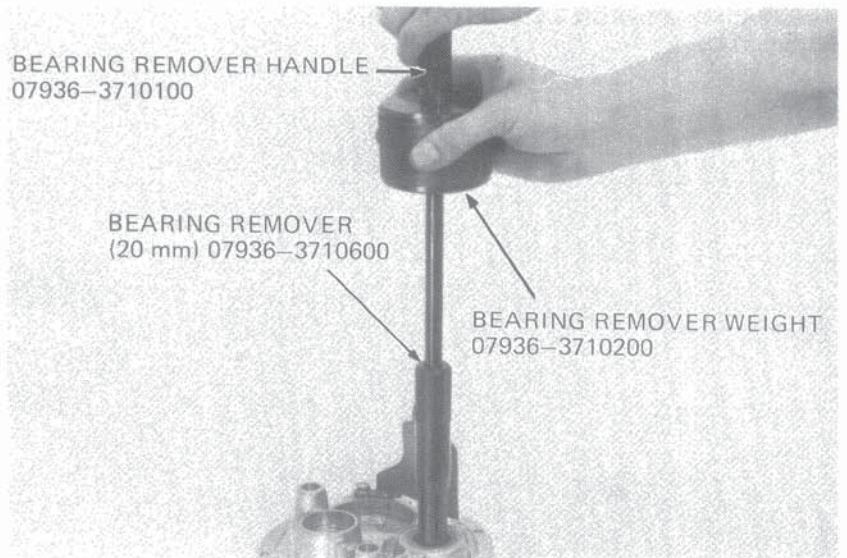





**TRANSMISSION**

Remove the mainshaft, countershaft bearings and oil guide plate.

**NOTE**

Bearings should be replaced if removed from case.

**TOOLS**

- COUNTERSHAFT BEARING BEARING DRIVER ATTACHMENT 07945-3330100
- BEARING DRIVE HANDLE 07949-6110000
- MAINSHAFT BEARING BEARING REMOVER (20 mm) 07936-3710600
- BEARING REMOVER HANDLE 07936-3710100
- BEARING REMOVER WEIGHT 07936-3710200

• **TRANSMISSION INSPECTION**

Check the gears for freedom of movement and rotation on the shaft.  
 Examine the gear dogs and slots for evidence of abnormal wear.  
 Measure each gear's I.D. If any gear exceeds the limit, the gear must be replaced.

**SERVICE LIMITS:**

<b>M2, M3, M4 and M5 GEARS</b>	<b>:25.10 mm (0.988 in.)</b>
<b>C1 GEAR</b>	<b>:24.10 mm (0.949 in.)</b>
<b>C2 GEAR</b>	<b>:27.60 mm (1.087 in.)</b>
<b>C3 and C4 GEARS</b>	<b>:25.10 mm (0.988 in.)</b>
<b>C5 GEAR</b>	<b>:32.10 mm (1.264 in.)</b>

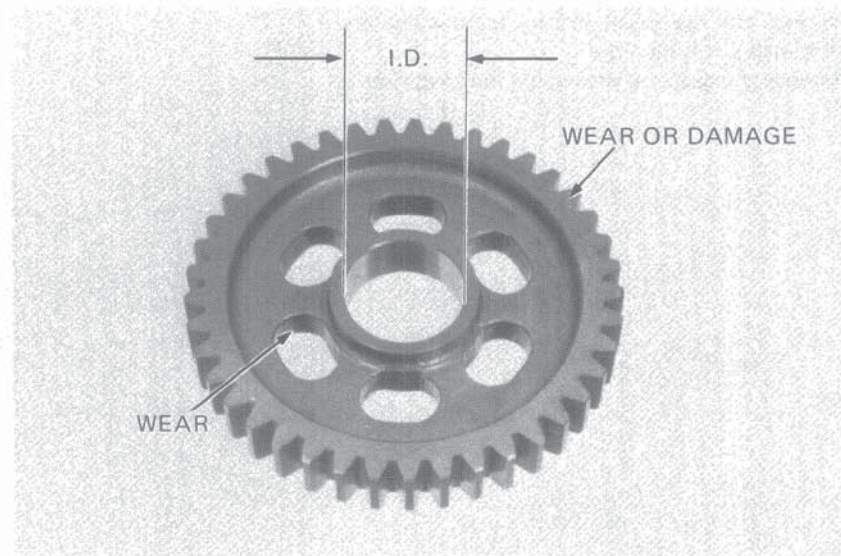
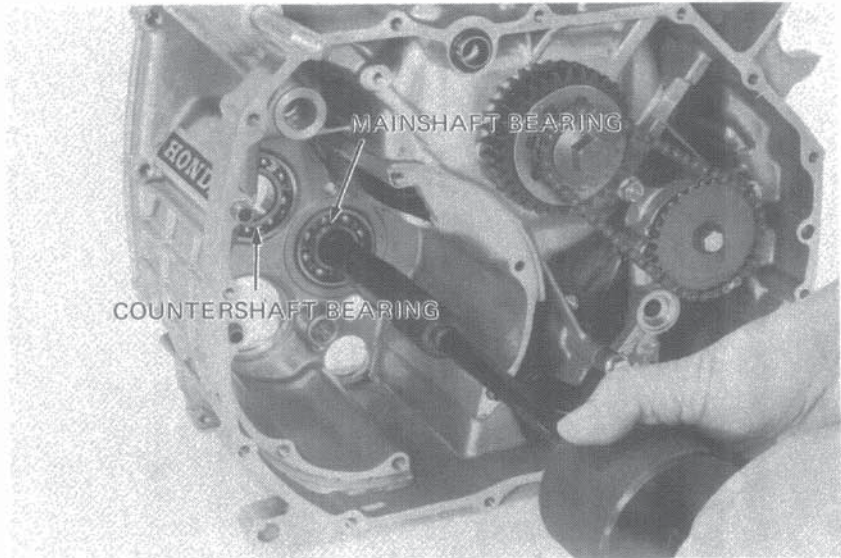

Measure the countershaft low gear (C1) bushing I.D. and O.D.

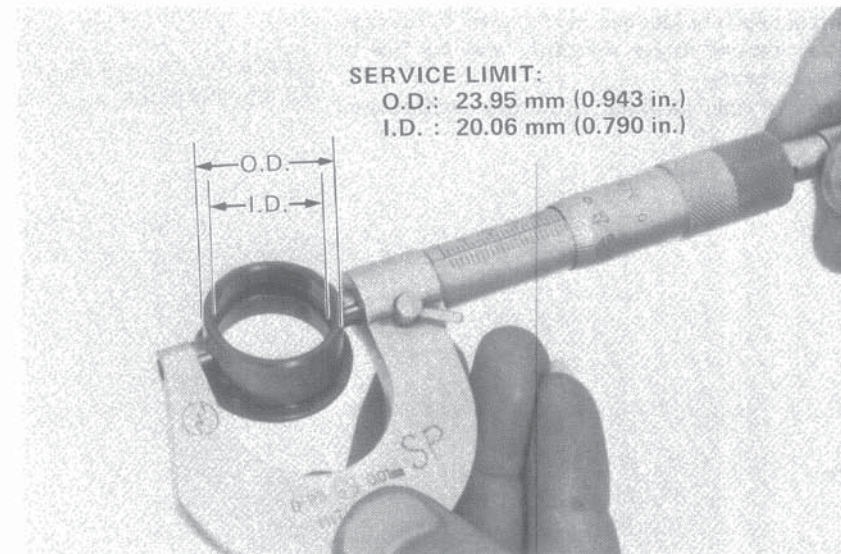

**SERVICE LIMIT:**  
 O.D.: 23.95 mm (0.943 in.)  
 I.D.: 20.06 mm (0.790 in.)





Measure and record the O.D. of the mainshaft and countershaft at the locations shown.

**SERVICE LIMITS:**

- A: 27.43 mm (1.080 in.)
- B: 31.91 mm (1.256 in.)
- C: 24.93 mm (0.982 in.)
- D: 19.96 mm (0.786 in.)
- E: 24.91 mm (0.781 in.)
- F: 24.91 mm (0.781 in.)

Calculate the clearance between the gear and gear shaft or bushing

**SERVICE LIMIT: 0.15 mm (0.0059 in.)**

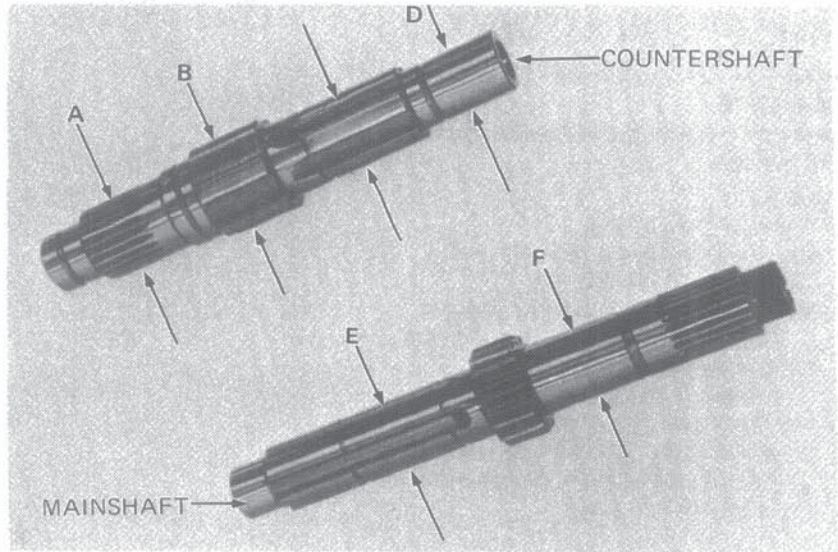

Measure the shift fork I.D. and claw thickness.  
Measure the shift fork shaft O.D.

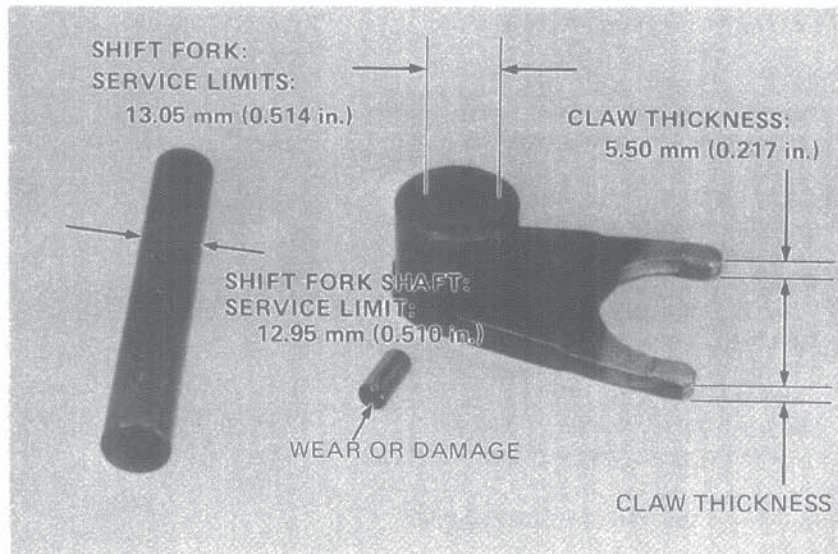

Measure the transmission holder I.D.  
Inspect each holder bearing for wear or damage.  
Spin the bearing by hand. Bearings must be replaced if they are noisy or have excessive play.

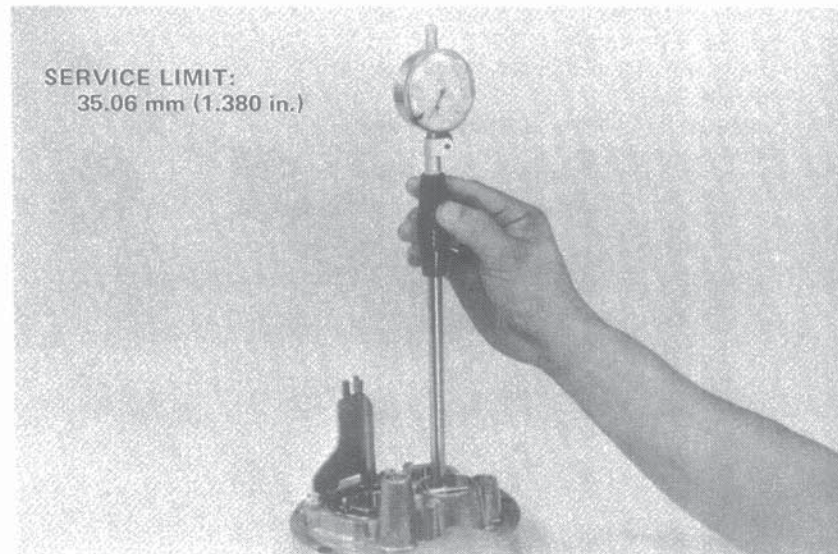





**TRANSMISSION**

**TRANSMISSION ASSEMBLY**

Install the oil guide plate in the mainshaft bearing hole.

Install the mainshaft and countershaft bearings into the case.

**TOOLS**

**MAINSHAFT BEARING**

BEARING DRIVER (42 x 47 mm)

BEARING PILOT (20 mm)

BEARING DRIVER ATTACHMENT

07946-3710200

BEARING DRIVER HANDLE

07949-3710000

**COUNTERSHAFT BEARING**

BEARING DRIVER (52 x 55 mm)

BEARING DRIVER PILOT (25 mm)

DRIVER HANDLE (A)

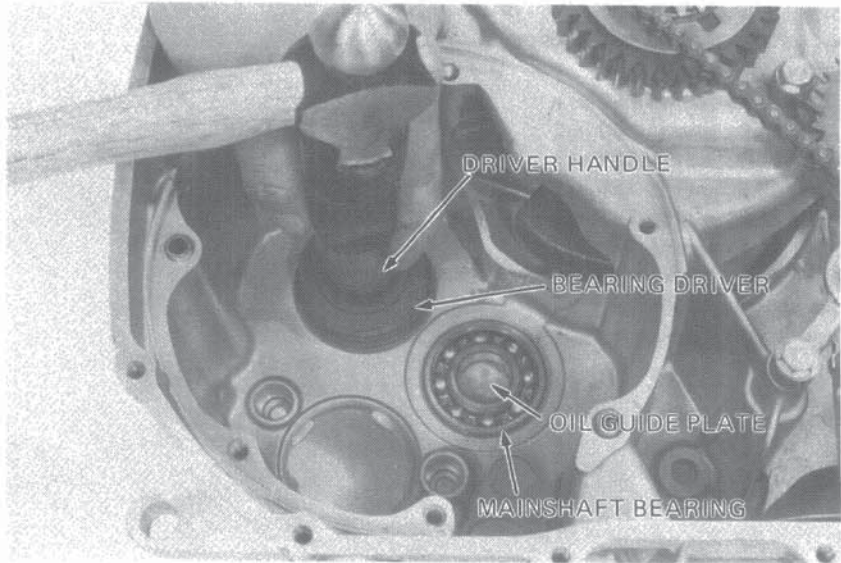

Install the transmission holder bearing.

**NOTE**

Support the transmission holder above the workbench to prevent damaging it.

**TOOLS**

DRIVER HANDLE (A)

07949-0010000

BEARING DRIVER ATTACHMENT

07946-3600000

BEARING DRIVER PILOT (25 mm)

BEARING DRIVER HANDLE

07949-6110000

NEEDLE BEARING BALL RACE

REMOVER/DRIVER 07946-3290200

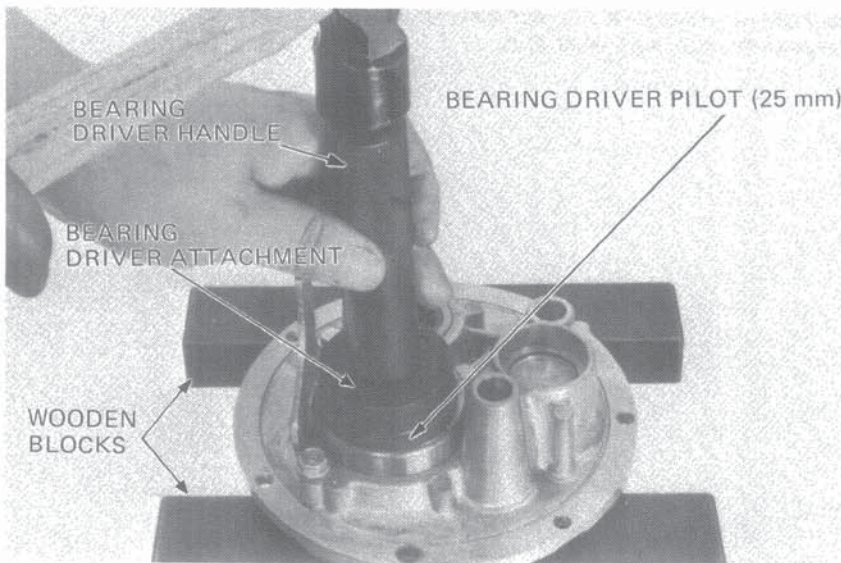

Assemble the mainshaft and countershaft.

**NOTE**

- Check the gears for freedom of movement or rotation.
- Check that all circlips are seated in their grooves.
- Lubricate the sliding surfaces of the gears with engine oil.

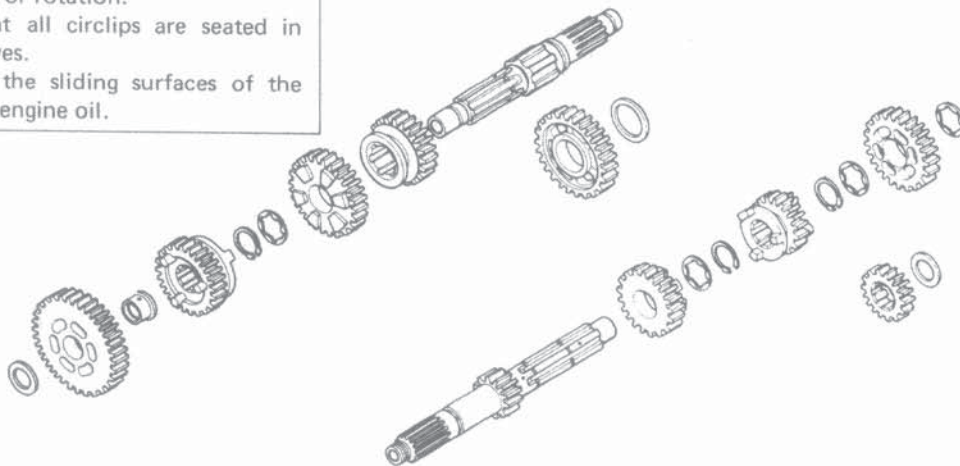





Insert the mainshaft, assembly into the holder bearing until it seats lightly.

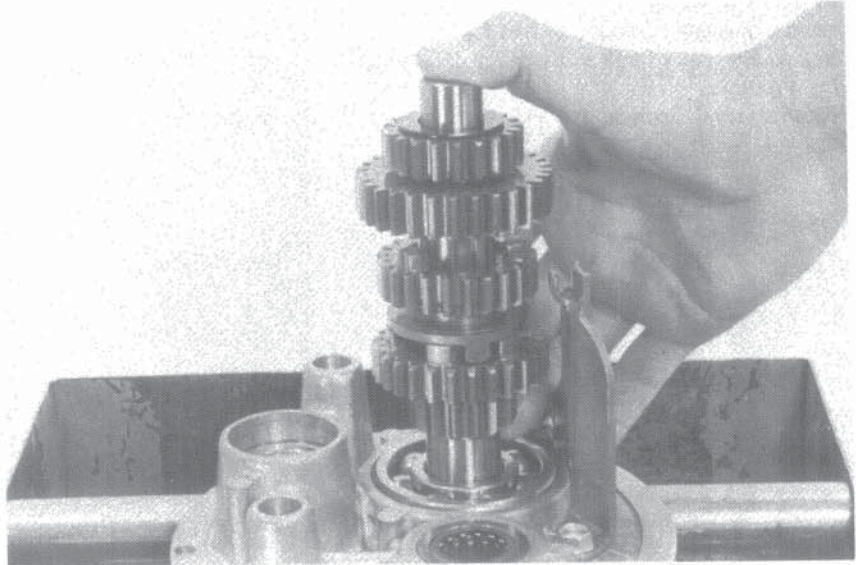

Insert the countershaft assembly into the bearing holder.  
Check the engagement of the gears on the countershaft and mainshaft.

**NOTE**

During installation, hold the thrust washer to prevent it from falling.

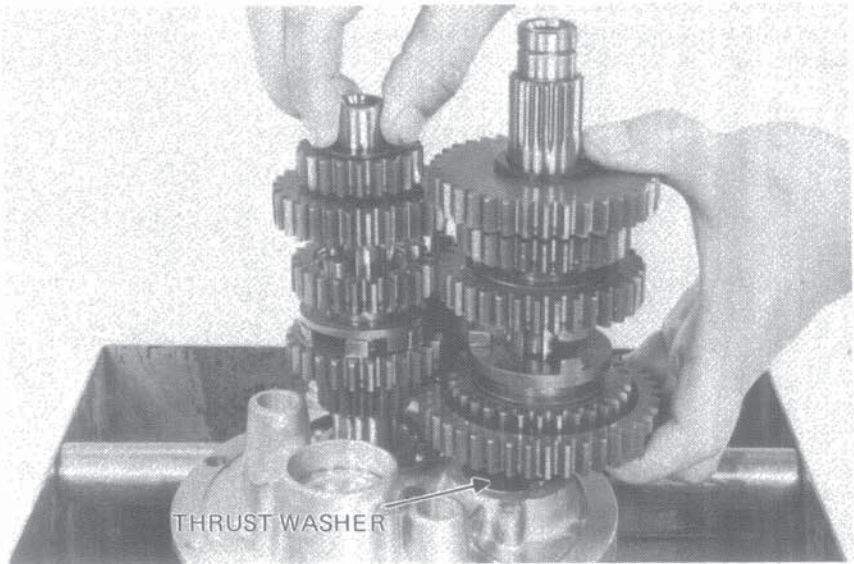

Press the gear assembly into position by lightly tapping the mainshaft with a soft hammer.

**NOTE**

Hold the countershaft low gear to prevent it from coming off.

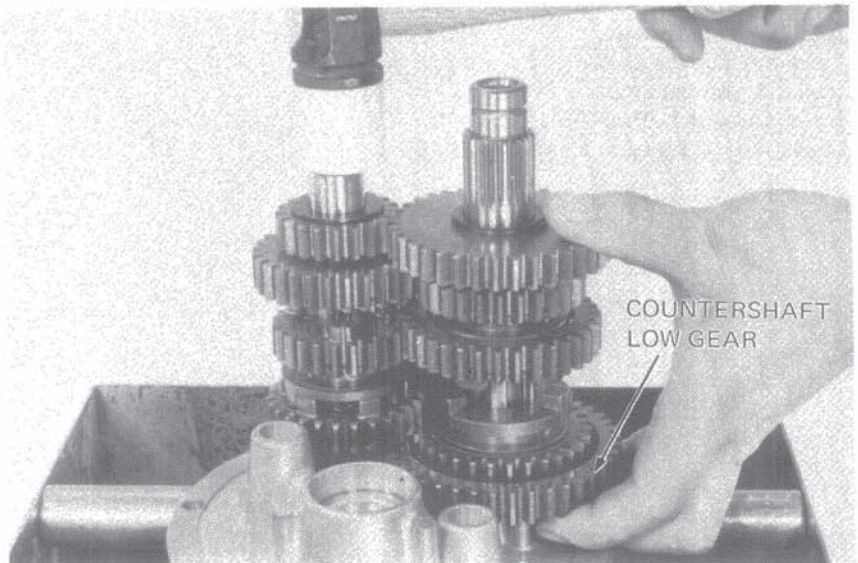





**TRANSMISSION**

Install the shift drum.  
Insert a guide pin into each shift fork.  
Engage the shift forks with the gears and shift drum groove.  
Install the shift fork shafts.

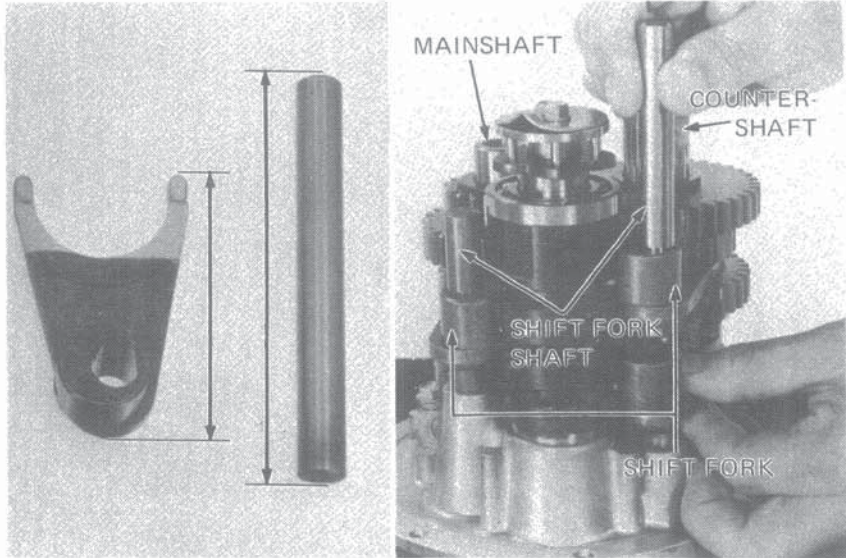

Place the transmission in neutral.  
Insert the transmission assembly into the engine case.

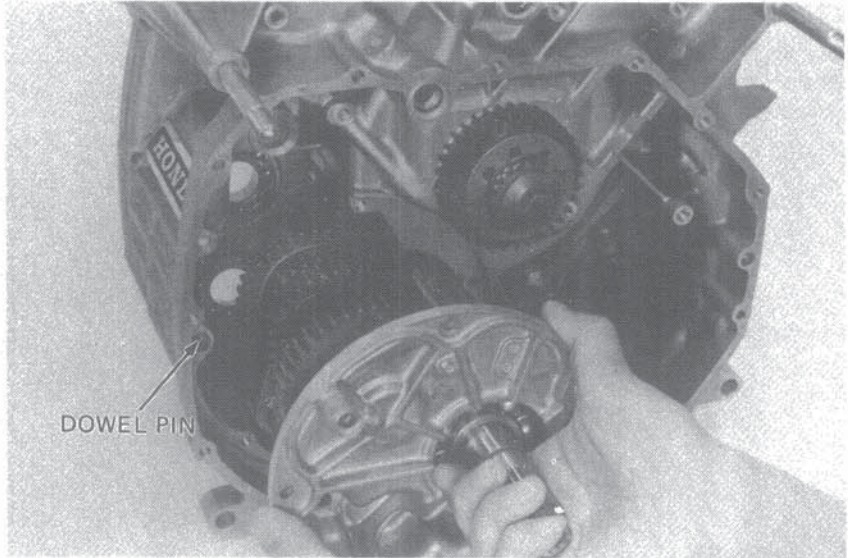

Press the transmission holder into place while rotating the mainshaft.  
Torque the holder bolts.  
Install the oil separator.  
Install the clutch (Page 7-6).  
Install the transmission cover (Page 7-13).

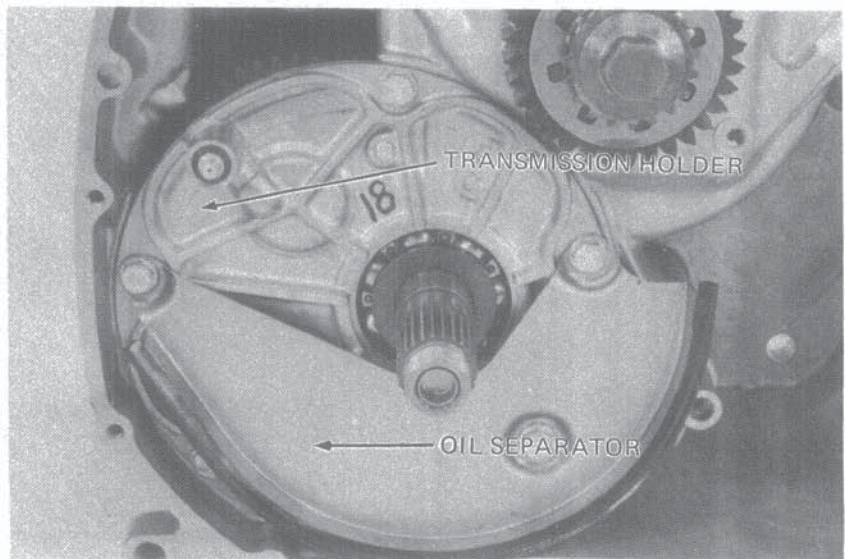





### GEARSHIFT LINKAGE INSTALLATION

Install the shift drum cam plate, pin, collar, center plate, and point plate.

Install the gearshift arm.

Install the spring on the shift arm and shift spindle.

Install the spindle.

Rotate the shift drum to neutral.

Install the drum stopper cam plate.

Apply a locking agent and tighten the 6 mm bolt.

Attach the stopper spring hook onto the case.

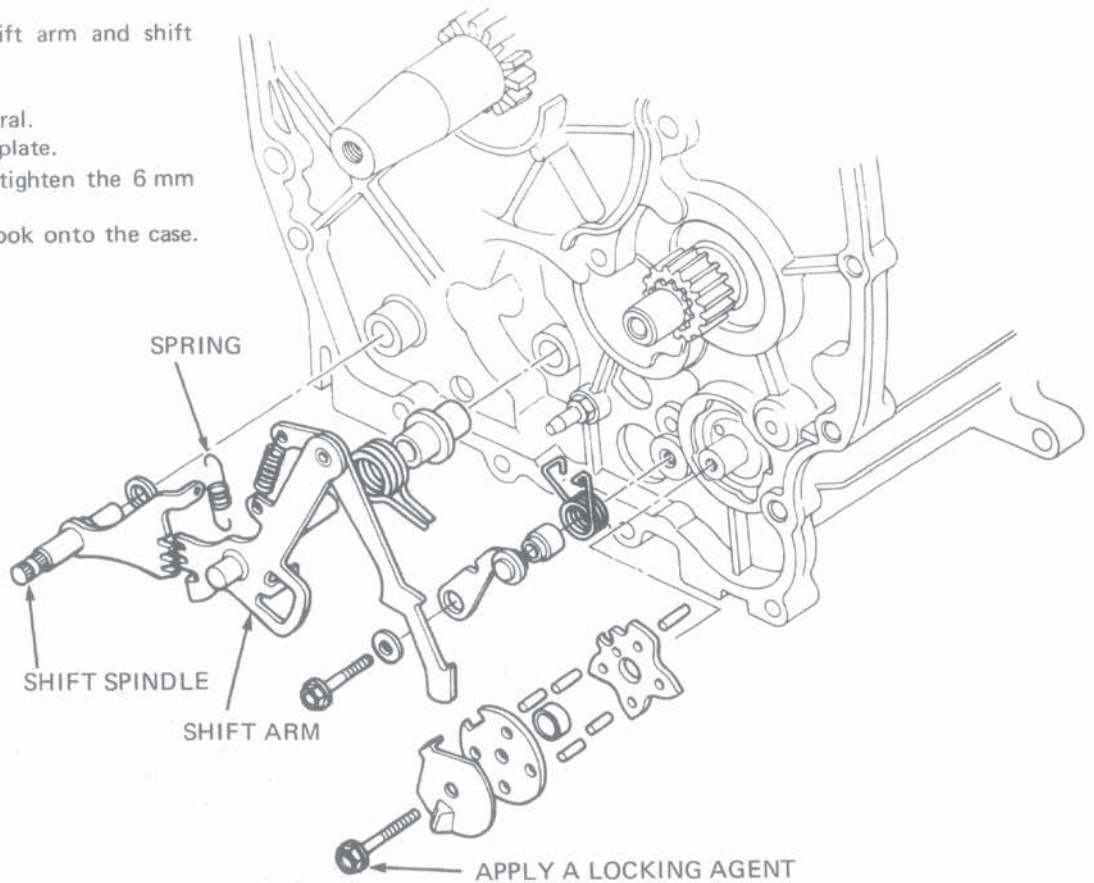

Install the final shaft.

Install the rear cover (See section 9).

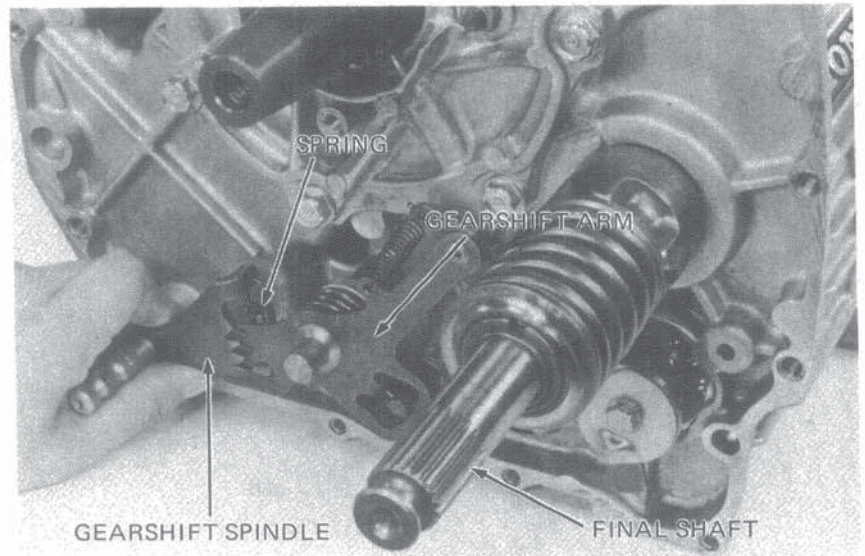

TRANSMISSION



**HONDA**  
**CX500**

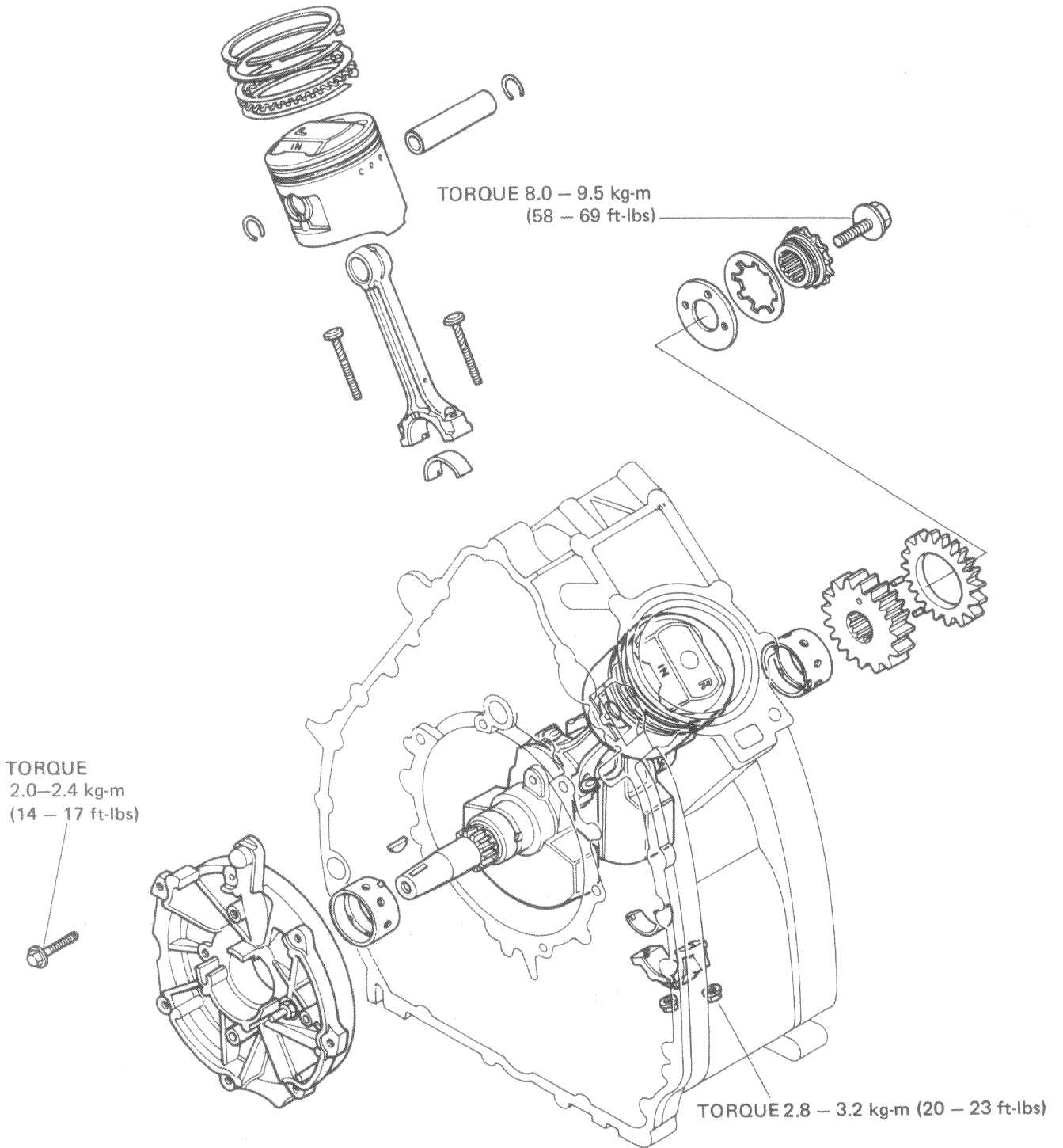





# 12. CRANKSHAFT/PISTON

SERVICE INFORMATION	12-1	MAIN JOURNAL BEARING REMOVAL	12-13
TROUBLESHOOTING	12-2	MAIN JOURNAL BEARING INSTALLATION	12-14
CONNECTING ROD REMOVAL	12-3	CRANKSHAFT INSTALLATION	12-15
PISTON REMOVAL	12-4	PISTON INSTALLATION	12-17
CYLINDER INSPECTION	12-5	CONNECTING ROD INSTALLATION	12-18
CRANKSHAFT REMOVAL	12-7		
BEARING INSPECTION/SELECTION	12-8		

## SERVICE INFORMATION

### • WORKING PRACTICE

All bearing inserts are a select fit and are identified by color codes. Select replacement bearing from the color code table. After installing new bearings, recheck them with plastigauge.

Before removing the piston and connecting rod assemblies, clean the top of the cylinder of carbon deposits.

The right piston can be serviced by removing the oil pump and transmission cover. To service the left piston, it is necessary to remove the transmission.

Apply molybdenum disulfide grease to the journals, crankpins and bearings during assembly.

### • SPECIAL TOOLS

Special tools

GEAR HOLDER	07924-4150000
PISTON REMOVER	07941-4150000
CRANK CAP PULLER	07935-4150000
CRANK CAP DRIVER	07945-4150100
MAIN BEARING DIS/ASSEMBLY TOOL	07973-4150000
PISTON SLIDER	07755-0010000

### • SPECIFICATIONS

Item		Standard	Service Limit
Crankshaft	Main journal oil clearance	0.020-0.060 mm (0.0008-0.0023 in)	0.085 mm (0.0033 in)
	Crankpin oil clearance	0.028-0.052 mm (0.0011-0.0020 in)	0.080 mm (0.0031 in)
	Connecting rod side clearance	0.150-0.350 mm (0.0059-0.0138 in)	0.060 mm (0.024 in)
Cylinder	I.D.	78.000-78.015 mm (3.0709-3.0715 in)	78.100 mm (3.0748 in)
	Warpage	—	0.10 mm (0.004 in)
Piston ring	Ring-to-groove clearance	Top	0.015-0.050 mm (0.0059-0.0020 in)
		Second	0.015-0.050 mm (0.0059-0.0020 in)
Piston pin	Ring end gap	Top	0.1-0.3 mm (0.004-0.0118 in)
		Second	0.1-0.3 mm (0.004-0.0118 in)
		Oil (side rail)	0.3-0.9 mm (0.004-0.0354 in)
	Piston O.D.	77.940-77.960 mm (3.0685-3.0693 in)	77.860 mm (3.0653 in)
	Piston pin bore	21.002-21.008 mm (0.8268-0.8271 in)	21.040 mm (0.8283 in)
	Piston pin O.D.	20.994-21.000 mm (0.8265-0.8268 in)	20.984 mm (0.8261 in)
	Small end I.D.	21.020-21.041 mm (0.8276-0.8284 in)	21.068 mm (0.8294 in)
	Piston-to-cylinder clearance	—	0.10 mm (0.004 in)



## TROUBLESHOOTING

### Excessive Noise

1. Crankshaft
  - Worn main bearing
  - Worn rod bearing
2. Piston and Connecting Rod
  - Worn piston or cylinder
  - Worn piston pin or pin hole
  - Worn rod small end

### Low Compression or Uneven Compression

1. Worn cylinder or piston ring

### Excessive Smoke

1. Worn cylinder, piston or piston rings
2. Improperly installed piston rings
3. Damaged piston or cylinder

### Overheating

1. Excessive carbon build-up on piston head
2. Blocked or restricted flow of coolant
3. Sticking thermostat

### Knocking or Abnormal Noise

1. Worn pistons and cylinders
2. Excessive carbon build-up on piston head





## CONNECTING ROD REMOVAL

Remove the cylinder head (Page 6-3).  
Remove the oil pump (Page 7-8).  
Remove the transmission (Page 11-4).  
Scrape all deposits from the top of the cylinder.

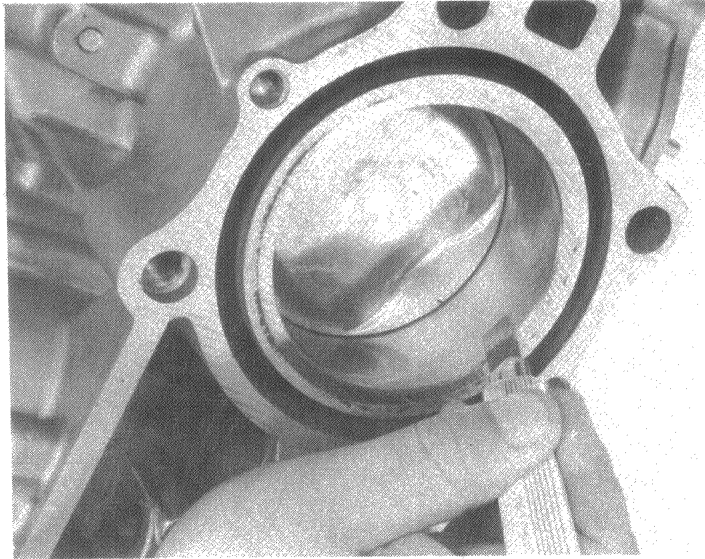

Turn the crankshaft so that the piston to be removed is at B.D.C. (Bottom Dead Center).  
Remove the bearing cap.  
Mark the bearing caps and rods to indicate cylinder position.  
Remove the left side cap from the transmission side. Work through the hole on the oil pump side to remove the right side cap.



Turn the crankshaft so that the piston is at T.D.C.  
Place the PISTON REMOVER over the rod bolts, and push the piston and rod assembly out.

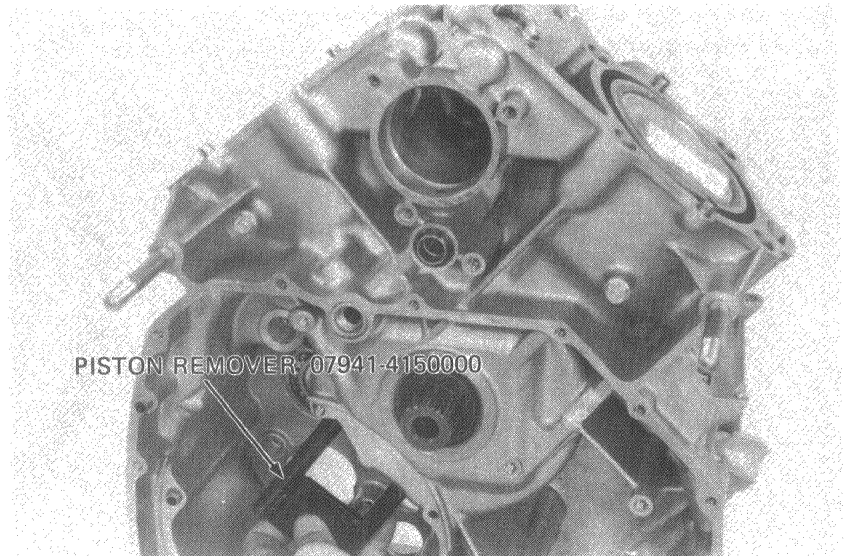



## PISTON REMOVAL

Remove the piston pin clips.  
Remove the pin.

**NOTE**

Mark the pins to indicate the piston position.

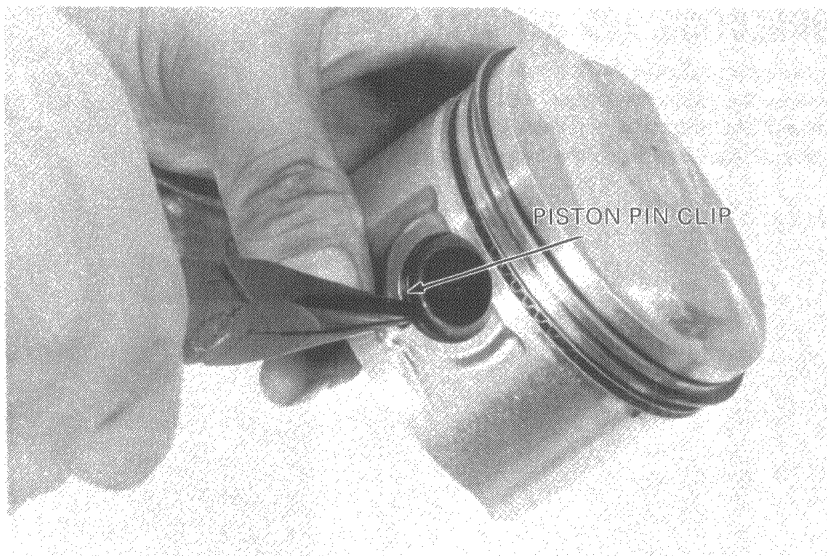

### • PISTON INSPECTION

Measure the ring-to-groove clearance.  
Remove the piston rings.

**NOTE**

Mark the rings so they can be assembled in their original position.

Clean and inspect the piston crown.  
Inspect the piston for damage and cracks; ring grooves for excessive wear.

**SERVICE LIMIT: 0.1 mm (0.004 in.)**  
**(TOP/SECOND)**

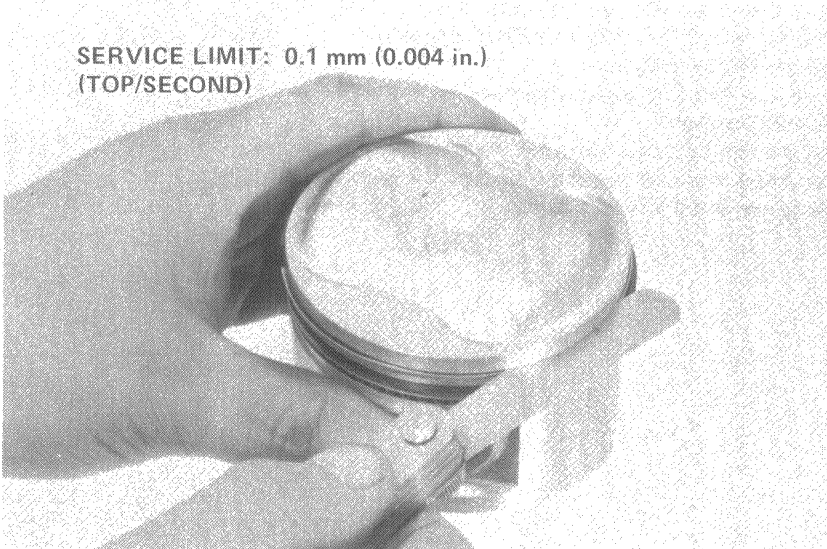

Insert each piston ring into the cylinder and measure the ring end gap.

**NOTE**

To measure the gap, use a piston and push the ring squarely into the cylinder.

**SERVICE LIMITS:**

**TOP** : 0.60 mm (0.024 in.)  
**SECOND** : 0.60 mm (0.024 in.)  
**OIL (SIDE RAIL)** : 1.10 mm (0.043 in.)

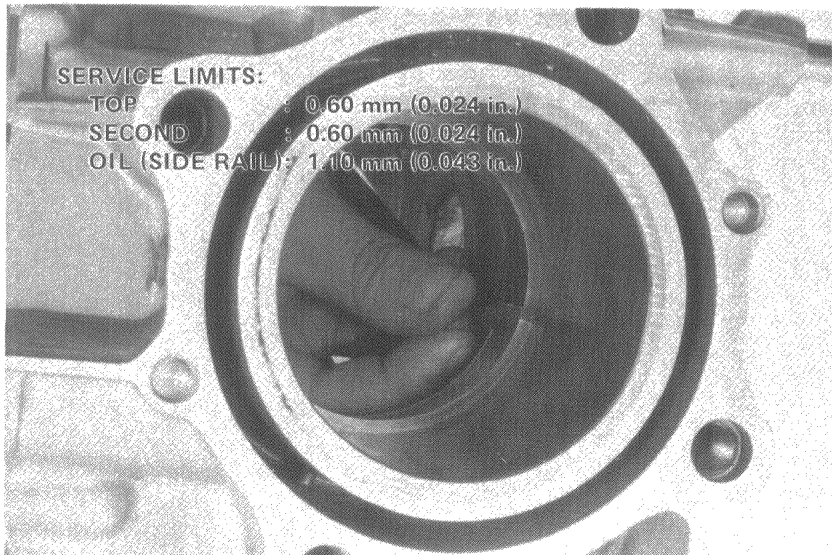





Measure each piston diameter at the skirt. If the pistons show wear beyond limits, replacement is necessary.

### NOTE

Measure the piston diameter 7–10 mm (0.28–0.4 in.) from the bottom of the piston, and 90° to the piston pin hole.

**SERVICE LIMIT: 77.86 mm (3.0653 in.)**

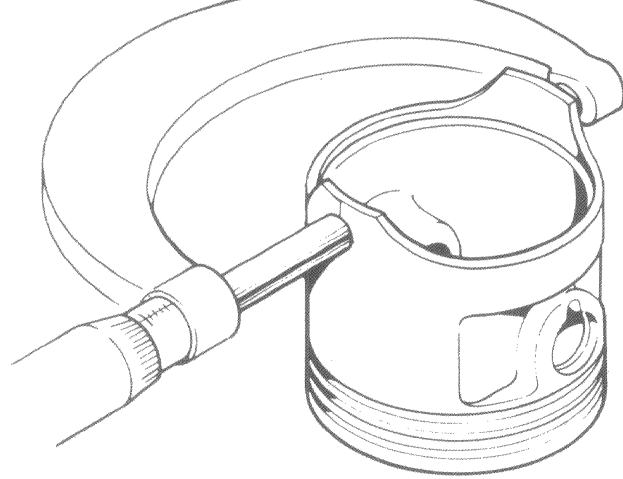

## CYLINDER INSPECTION

Measure the cylinder I.D.

Calculate the piston to cylinder clearance.

**SERVICE LIMIT: 0.10 mm (0.004 in.)**

Oversize pistons are available in standard and the following sizes: 0.25 and 0.50 mm.

**SERVICE LIMIT: 78.10 mm (3.0748 in.)**

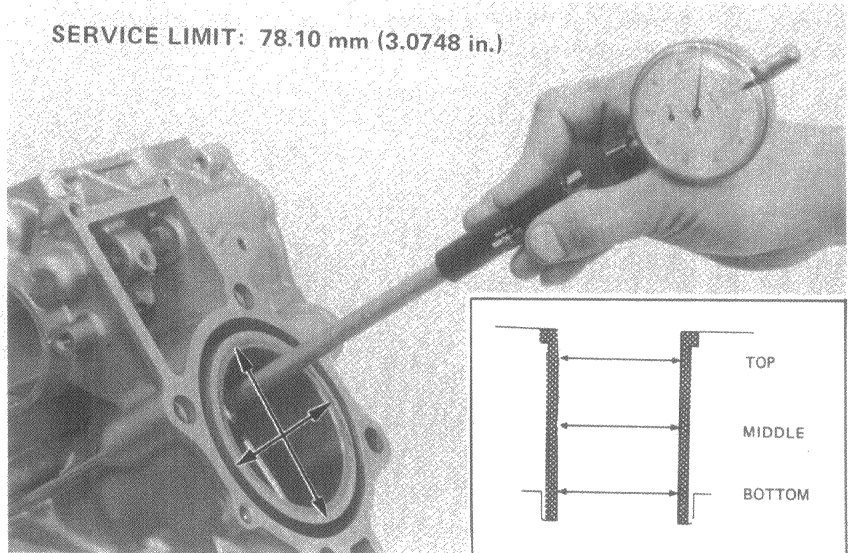

Measure each piston pin bore.

**SERVICE LIMIT: 21.04 mm (0.8283 in.)**

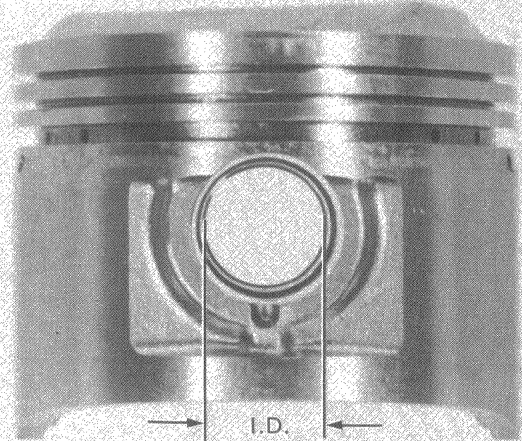



**CRANKSHAFT/PISTON**

Measure each piston pin O.D.

**SERVICE LIMIT: 20.984 mm (0.8261 in.)**

Calculate the piston pin to piston clearance.

**SERVICE LIMIT: 0.05 mm (0.002 in.)**

**SERVICE LIMIT: 20.984 mm (0.8261 in.)**

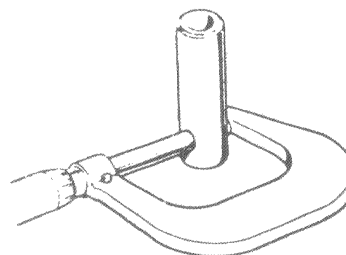

Measure the rod end I.D. If the reading exceeds the service limit, replace the rod.

**SERVICE LIMIT: 21.068 mm (0.8294 in.)**

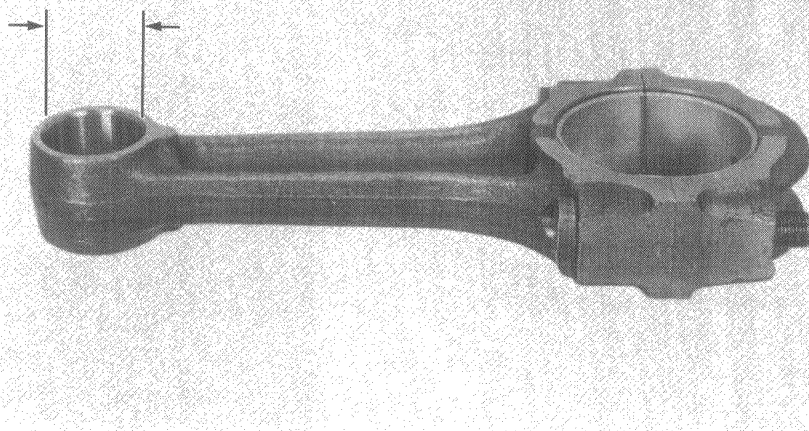





## CRANKSHAFT REMOVAL

Hold the primary drive gear with a GEAR HOLDER.

Remove the 12 mm bolt and the oil pump sprocket, disc spring, side plate, sub gear and primary gear.

### NOTE

Mark the sub gear and side plate so that they will face the correct direction during reassembly.

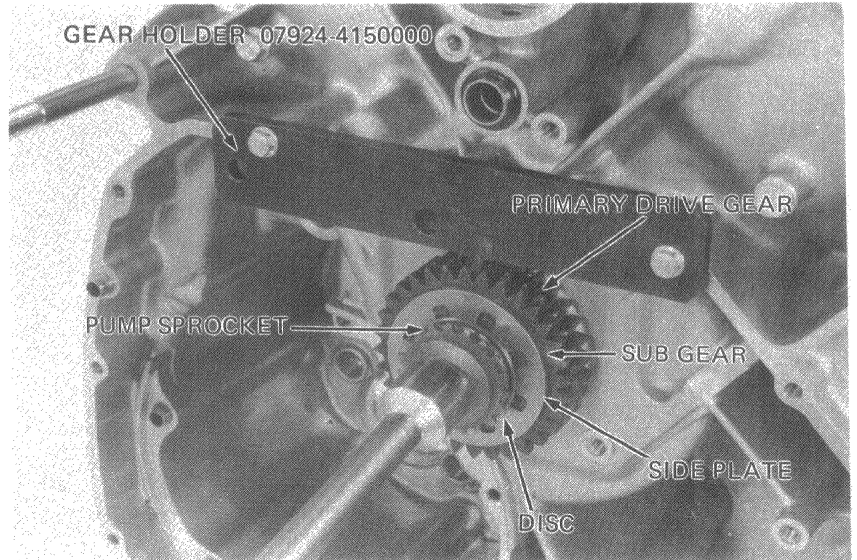

Remove the flywheel and cam chain (Page 10-2).  
Remove the crankshaft cap bolts.

### NOTE

Before removing the crankshaft, wrap the splines of the primary gear and timing sprocket with vinyl tape to prevent damage to them.

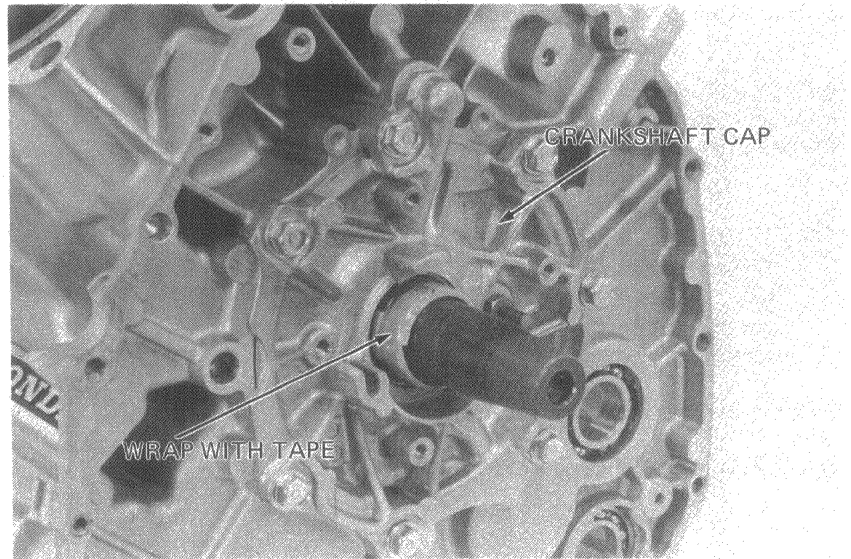

Attach the CRANK CAP PULLER to the front of the engine.

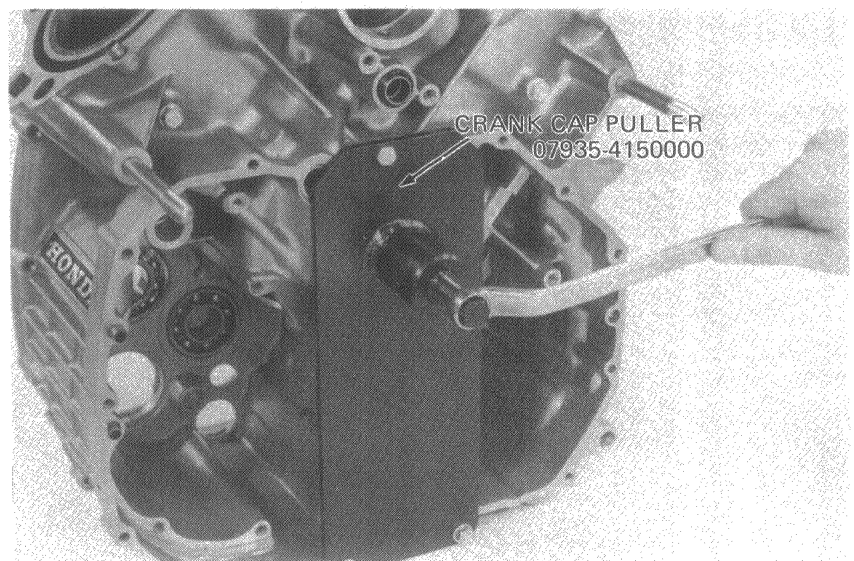



**CRANKSHAFT/PISTON**

Press the crankshaft out by screwing in the REMOVER.

**CAUTION**

*Do not damage the bearing. when removing the crankshaft.*

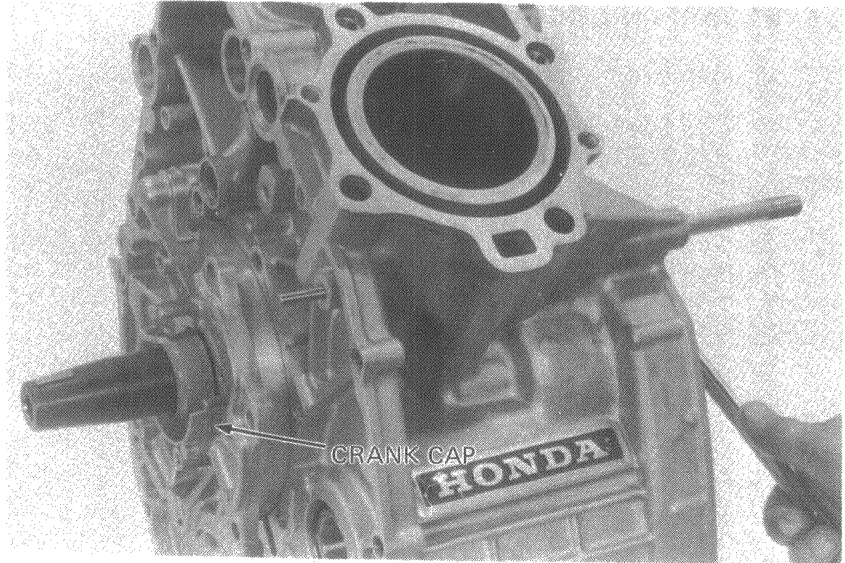

● **ROD SIDE CLEARANCE INSPECTION**

Install each connecting rod and bearing cap in its original position and torque to specifications.  
**TORQUE VALUE: 2.8–3.2 kg-m**  
**(20–23 ft-lbs)**

**NOTE**

- Torque the cap bolts evenly in 2–3 steps.
- Do not rotate the crankshaft during inspection.

Measure the rod side clearance with a feeler gauge.

**SERVICE LIMIT: 0.60 mm (0.024 in)**

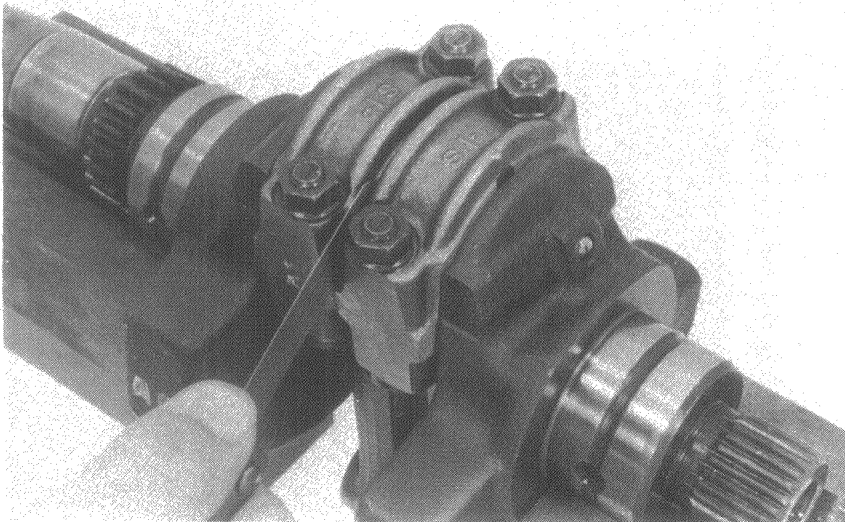

**BEARING INSPECTION/SELECTION**

● **CRANKPIN**

Inspect each bearing insert for separation or other damage.

Put the connecting rod inserts in each rod cap. Place a plastigauge strip across each rod crankpin avoiding the oil hole.

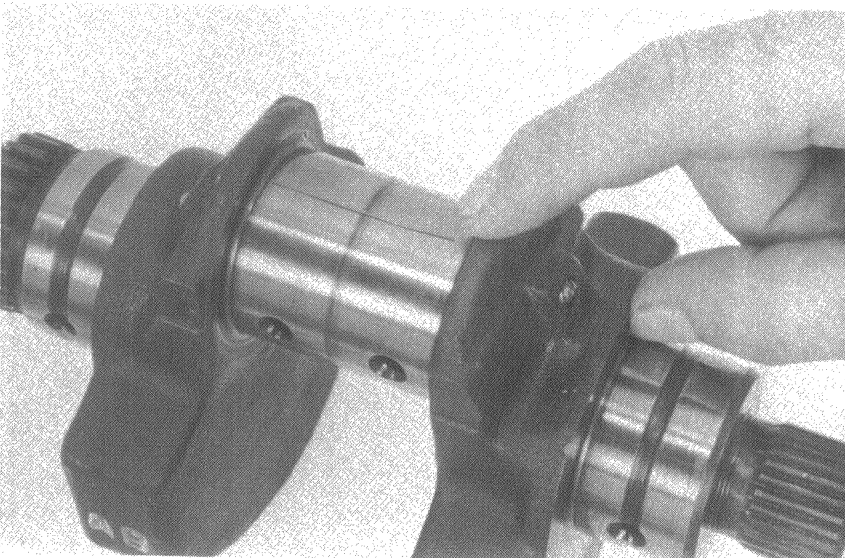





Install each connecting rod and bearing cap in their original positions and torque to specifications.

### NOTE

- Torque the cap bolts evenly in 2–3 steps.
- Do not rotate the crankshaft during the inspection.

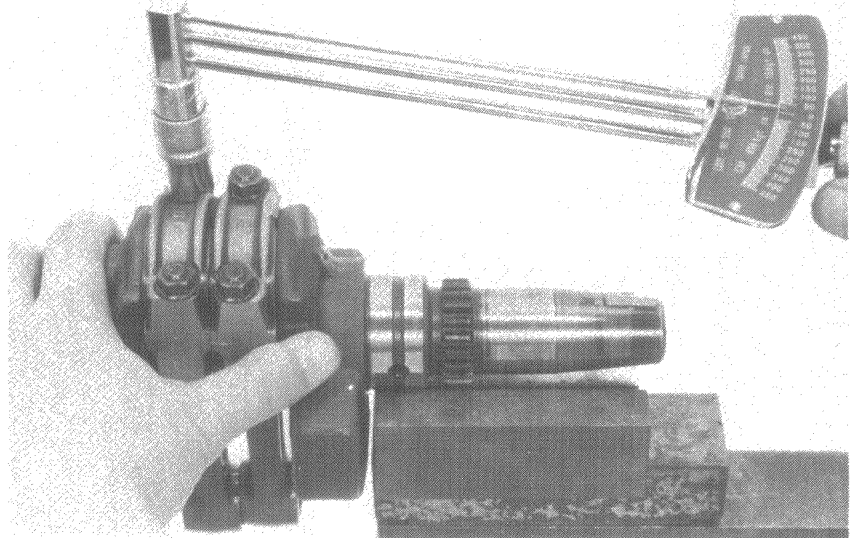

Remove the caps and measure the compressed plastigauge.

### NOTE

The widest thickness determines the oil clearance.

**SERVICE LIMIT: 0.08 mm (0.0031 in.)**

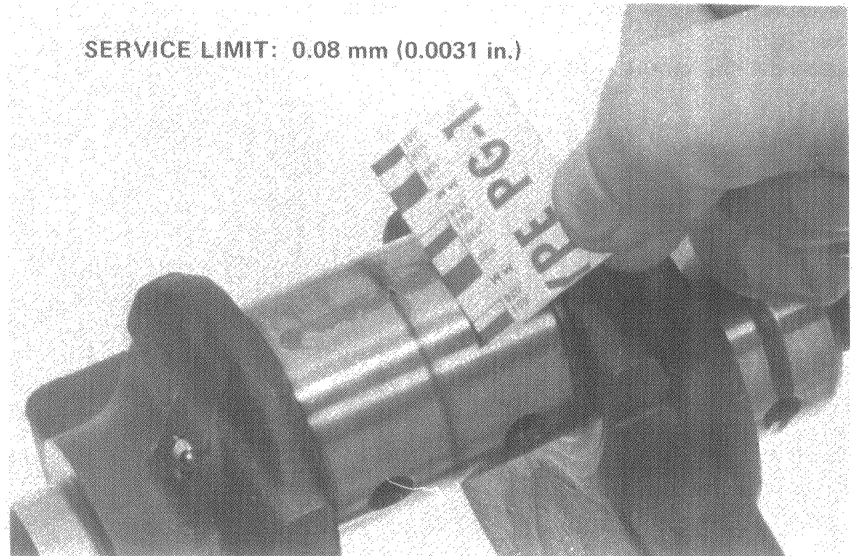

- **MAIN JOURNAL**  
Measure each journal O.D.

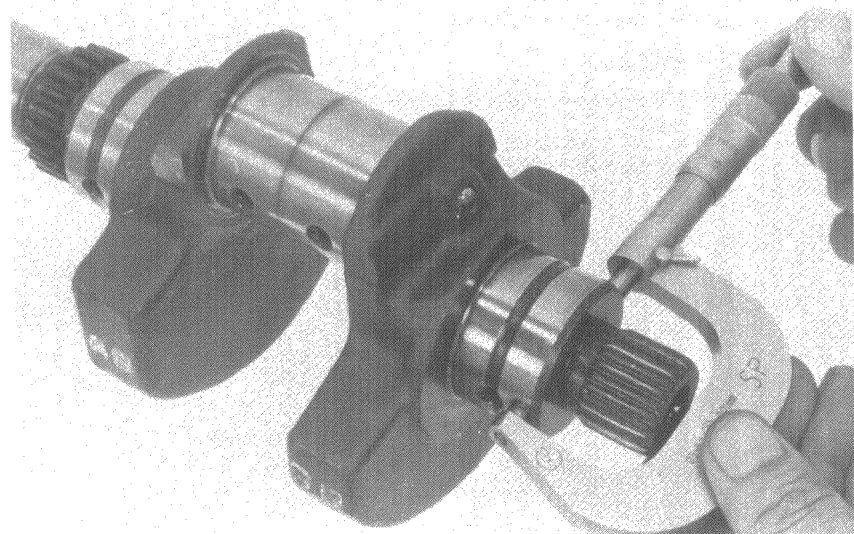

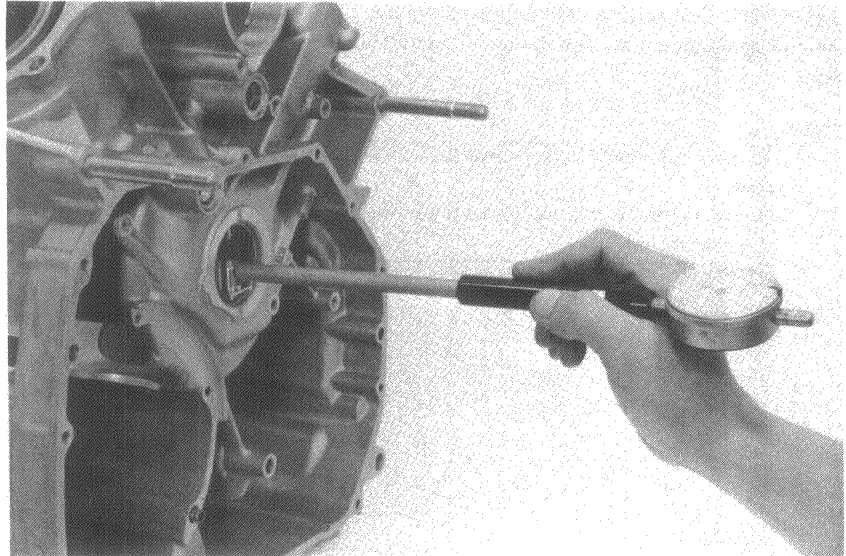

Measure the engine case and crankshaft bearing cap I.D.  
Calculate the journal to bearing cap clearance.

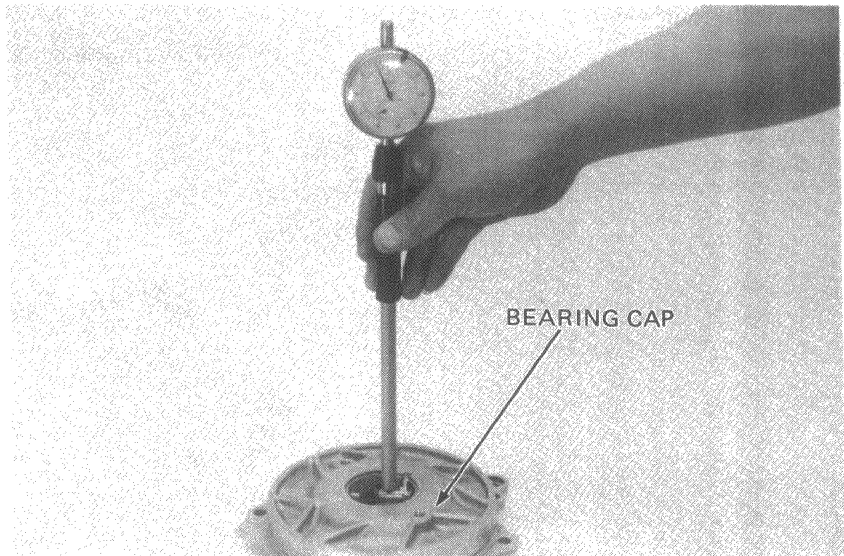

If rod bearing clearance is beyond tolerance, select replacement bearings as follows.

• **ROD BEARINGS**

Determine and record each connecting rod I.D. code number.

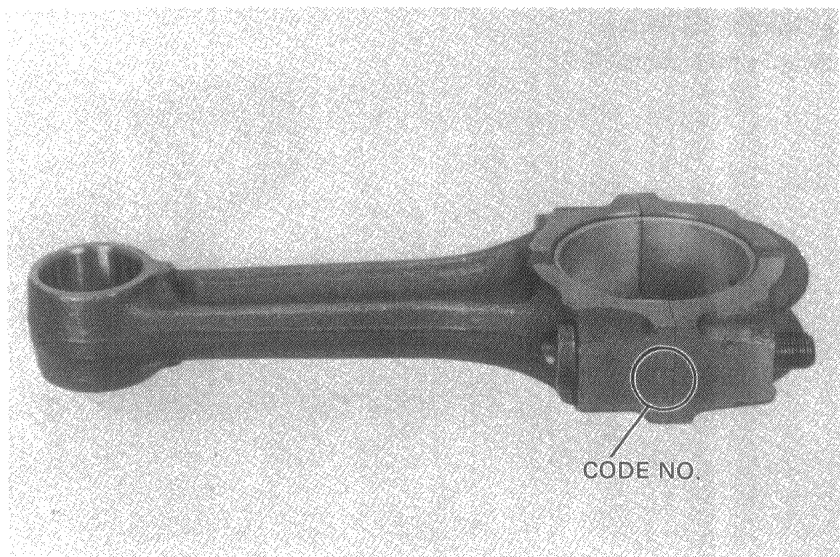





Determine and record the corresponding crankpin O.D. code letters.

Cross reference the crank pin and rod codes to determine the replacement bearing color.

### ROD BEARING SELECTION

CRANKPIN SIZE CODE LETTER	A	B	C	
	39.982–39.990 mm (1.5741–1.5744 in.)	39.974–39.982 mm (1.5738–1.5741 in.)	39.966–39.974 mm (1.5735–1.5738 in.)	
CONNECTING ROD I.D. CODE NUMBER	COLOR IDENTIFICATION			
	1. 43.000–43.008 mm (1.6929–1.6932 in.)	PINK	YELLOW	GREEN
	2. 43.008–43.016 mm (1.6932–1.6935 in.)	YELLOW	GREEN	BROWN
	3. 43.016–43.024 mm (1.6935–1.6939 in.)	GREEN	BROWN	BLACK

### ROD BEARING SIZES

COLOR	BEARING THICKNESS
BLACK	1.503–1.507 mm
BROWN	1.499–1.503 mm
GREEN	1.495–1.499 mm
YELLOW	1.491–1.495 mm
PINK	1.487–1.491 mm

### NOTE

After fitting new bearing inserts, they should be rechecked with plastigauge.

### ● MAIN JOURNAL BEARINGS

Determine and record the main journal O.D. codes.

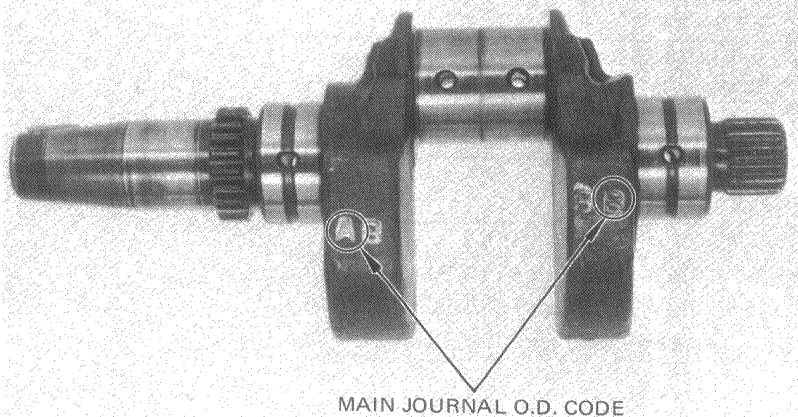
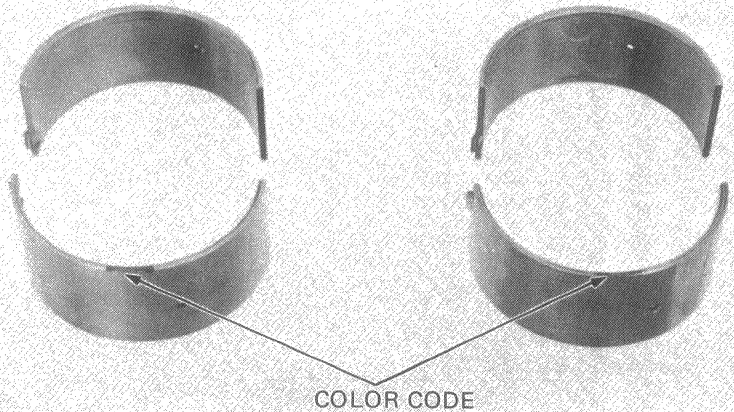
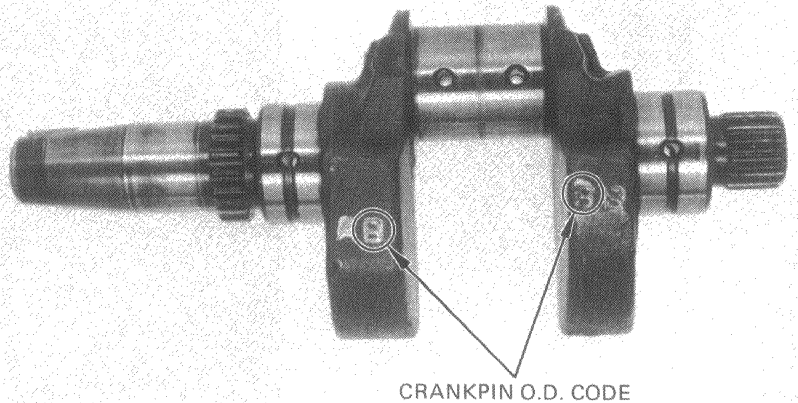

**CRANKSHAFT/PISTON**

Measure the engine case bearing support I.D.

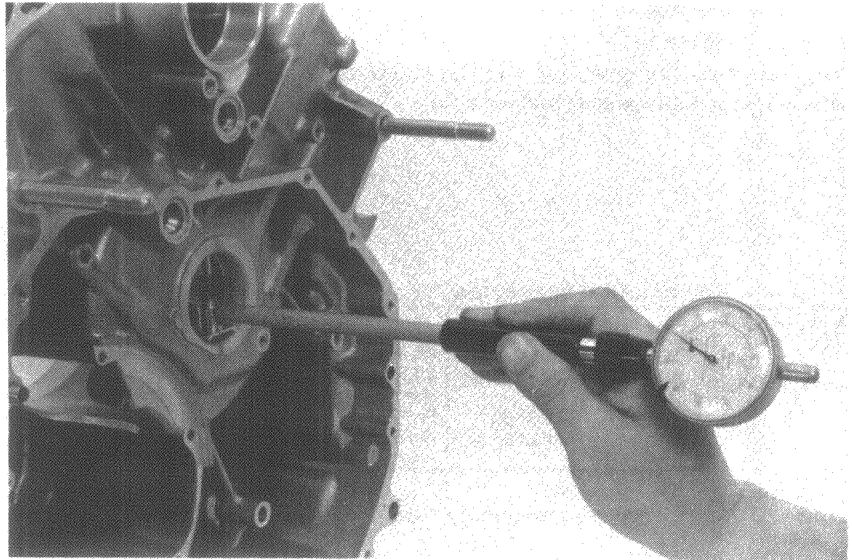

Measure the crankshaft cap bearing support I.D.

Cross reference the bearing support I.D. and crank journal codes to determine the replacement bearing color.

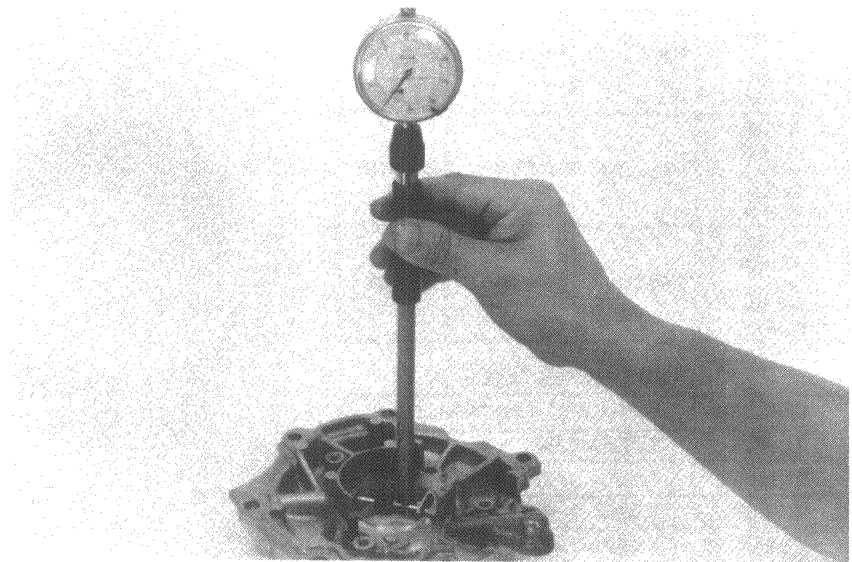
**MAIN BEARING SELECTION**

	MAIN JOURNAL SIZE CODES	
	A	B
CRANKCASE/CAP BEARING SUPPORT I.D.	BEARING IDENTIFICATION COLOR	
47.000–47.010 mm (1.8504–1.8508 in.)	BROWN	BLACK
47.010–47.020 mm (1.8508–1.8517 in.)	BLACK	BLUE

**JOURNAL BEARING SIZES**

COLOR	THICKNESS
BROWN	1.989–1.999 mm (0.0783–0.0787 in.)
BLACK	1.994–2.004 mm (0.0785–0.0789 in.)
BLUE	1.999–2.009 mm (0.0787–0.0791 in.)

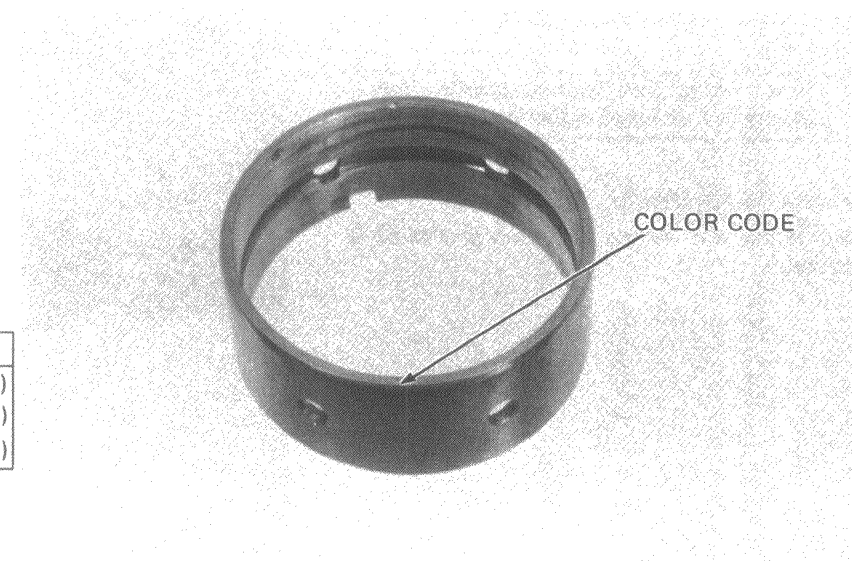





### MAIN JOURNAL BEARING REMOVAL

Press the bearing out with a hydraulic press and bearing DIS/ASSEMBLY tool.

**CAUTION**

*To prevent engine case damage, always use a hydraulic press and bearing removal tool to remove bearings.*

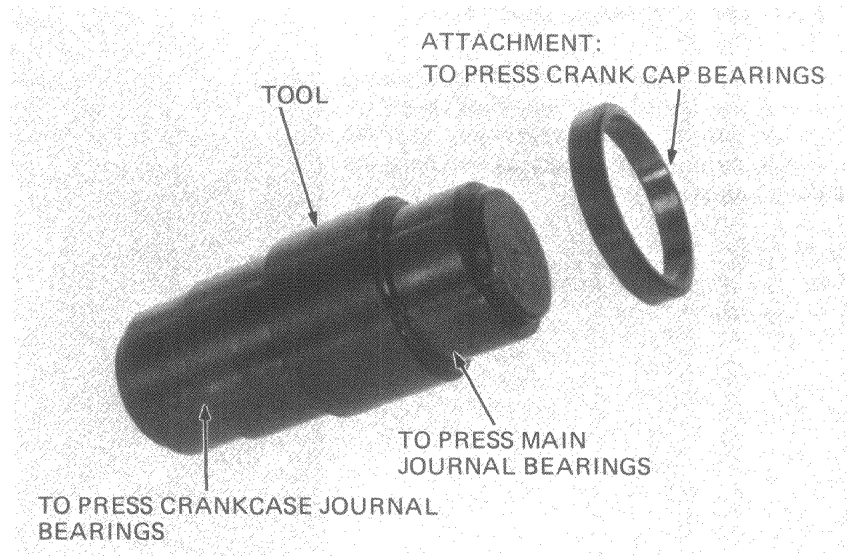
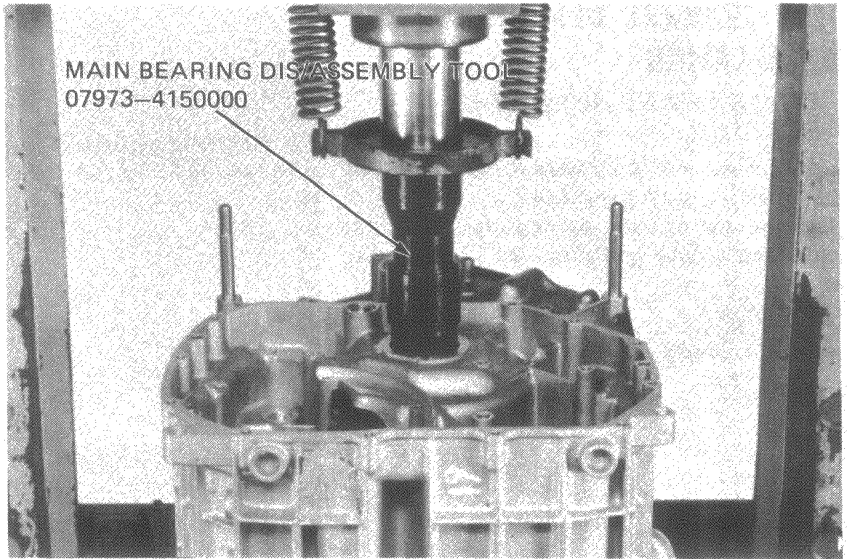

Press the bearings out of the crankshaft cap bearing support with a hydraulic press and bearing removal tool.

**CAUTION**

*To prevent crankshaft cap damage, always use a hydraulic press and bearing removal tool to remove bearings.*

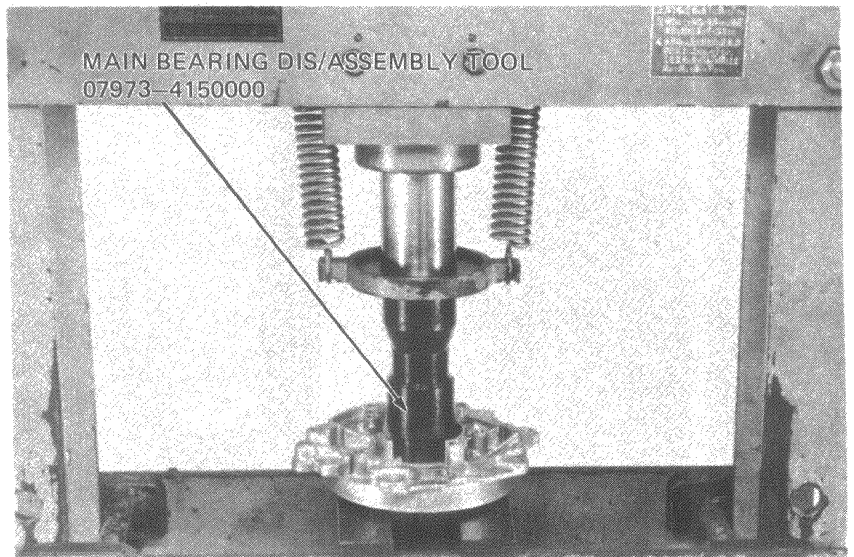



## MAIN JOURNAL BEARING INSTALLATION

### • CRANKSHAFT HOLDER CAP BEARING

Apply engine oil or molybdenum disulfide grease to the bearing outer periphery.

Align the tab of each bearing insert with the holder cap groove and press the bearings into place.

**CAUTION**

*Do not damage the bearings, when press fitting them.*

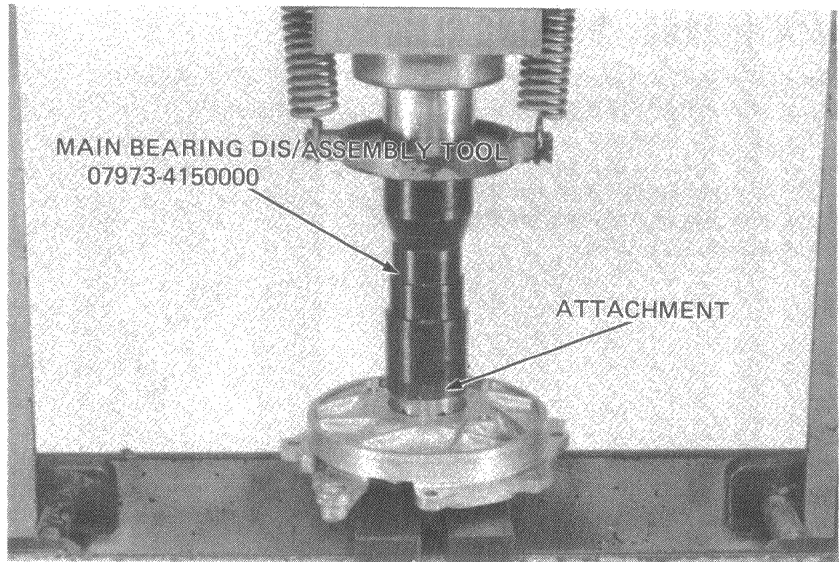

### • CRANKCASE MAIN JOURNAL BEARINGS

Lubricate the outer periphery of each bearing with engine oil or molybdenum disulfide grease. Align the tab of each bearing insert with the crankcase bearing support groove and press the bearings into place.

**CAUTION**

*Do not damage the bearings, when press fitting them.*

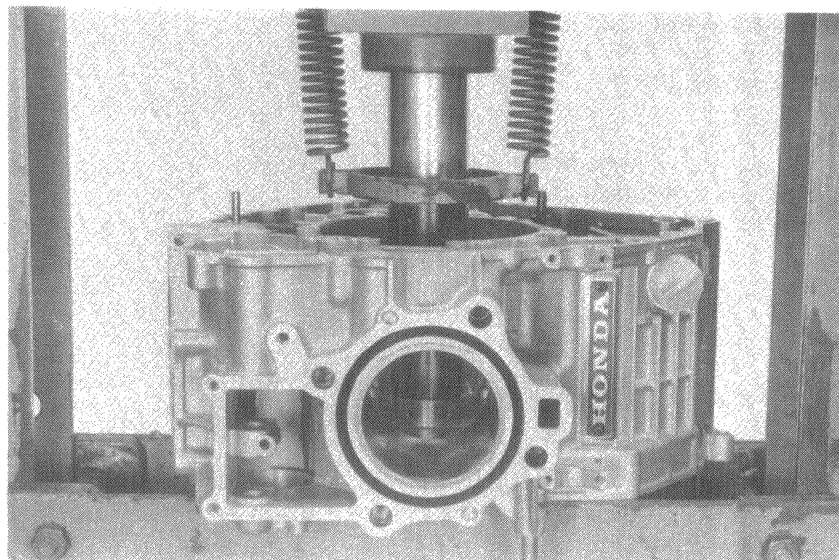
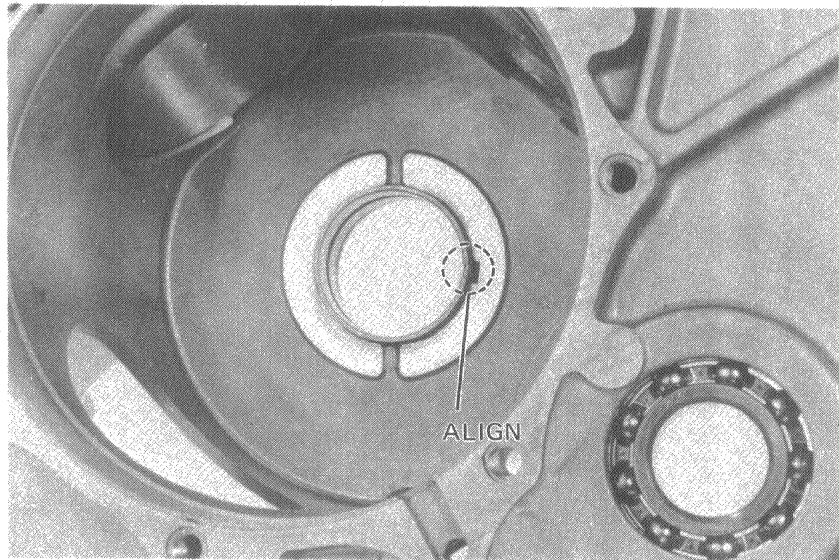





## CRANKSHAFT INSTALLATION

Install the lower main bearing inserts.  
Install the crankshaft.

### NOTE

- Lubricate the bearings, main journals and crankpins with molybdenum disulfide grease.
- Wrap the splines of the crankshaft and timing gear area with vinyl tape to prevent damage.

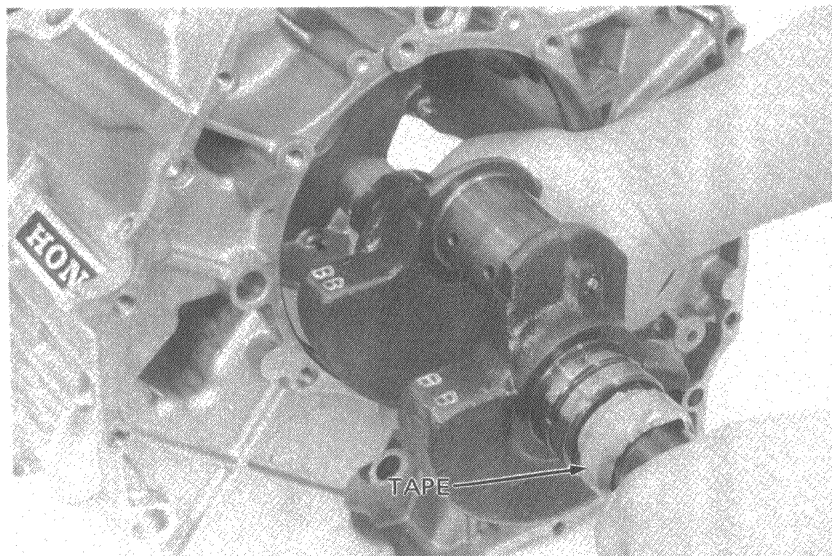

Install the O-ring and collar.  
Install the crankshaft holder cap.  
Install the guide bolts in the crankshaft holder cap as shown.

### NOTE

- Lubricate the bearing with molybdenum disulfide grease.
- Screw in the guide bolts so that the cap is not tilted.

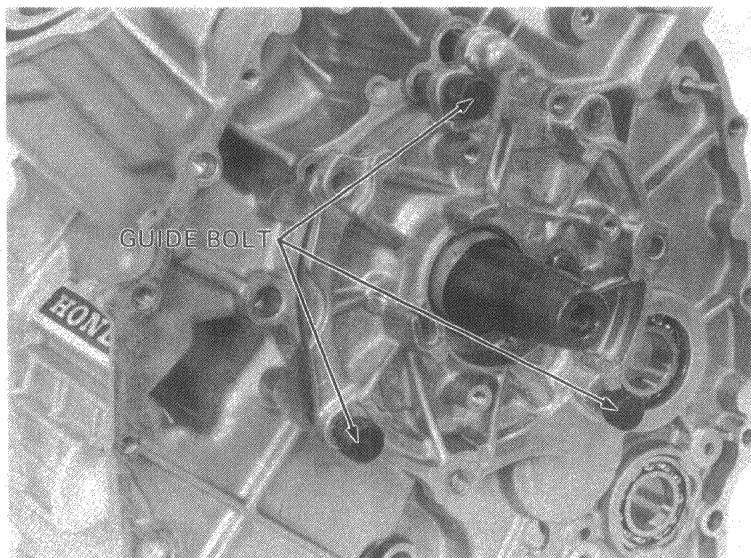

Drive the crankshaft holder cap into place with a hammer and driver.

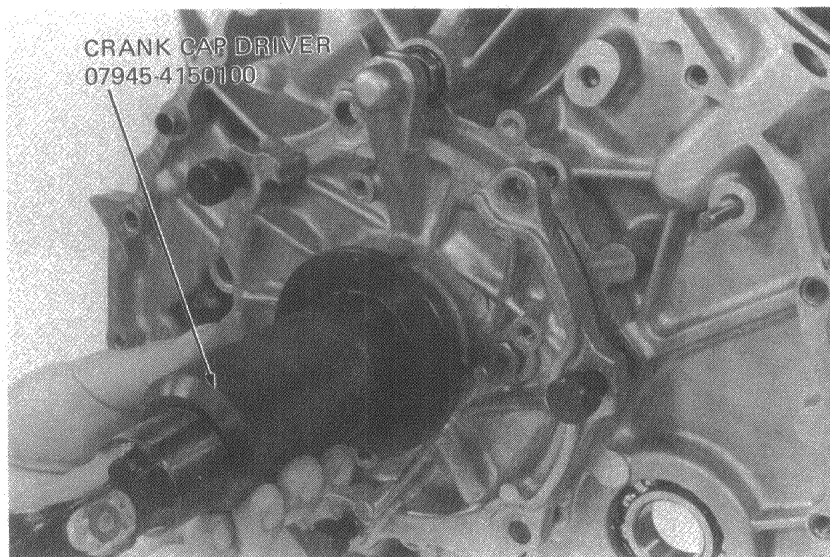



**CRANKSHAFT/PISTON**

Tighten the cap bolts.

**NOTE**

After tightening the bolts, make sure that the crankshaft rotates freely.

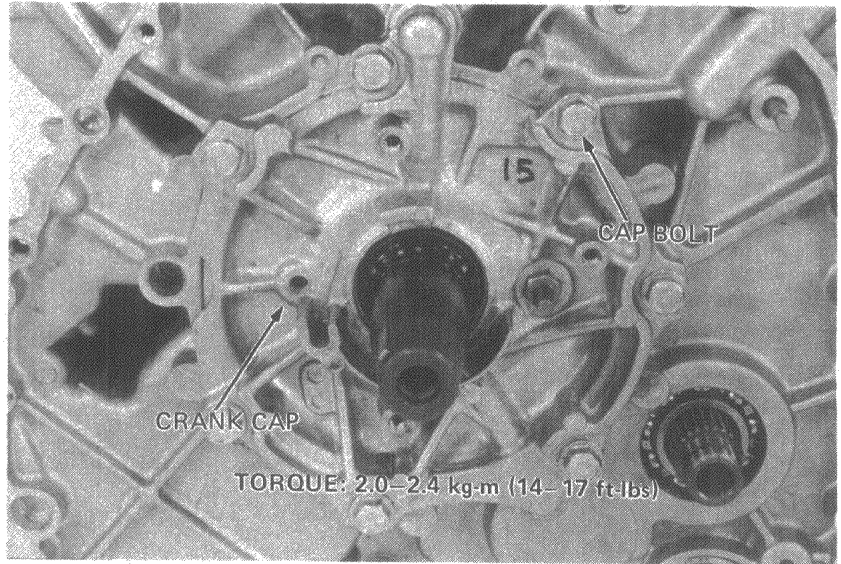

Install the primary gear, primary sub gear, side plate, disc spring and oil pump drive sprocket.

**NOTE**

- Install the dish spring with the pawls placed over the dowel pins to prevent them from coming out during operation.
- Before assembling, lubricate all parts with engine oil.
- Note the primary sub gear and side plate directions by referring to the marks made during disassembly.

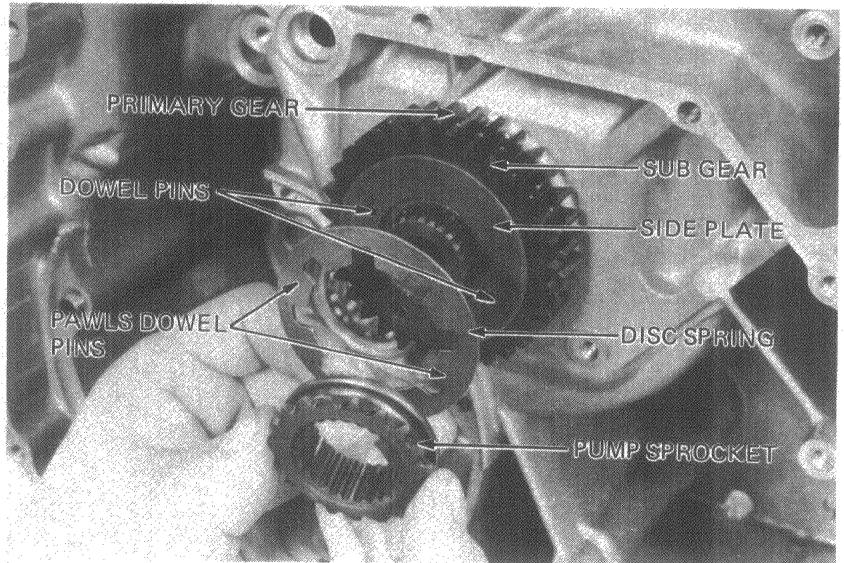

Install the DRIVE GEAR HOLDER to prevent the drive gear from turning.  
Torque the primary gear.

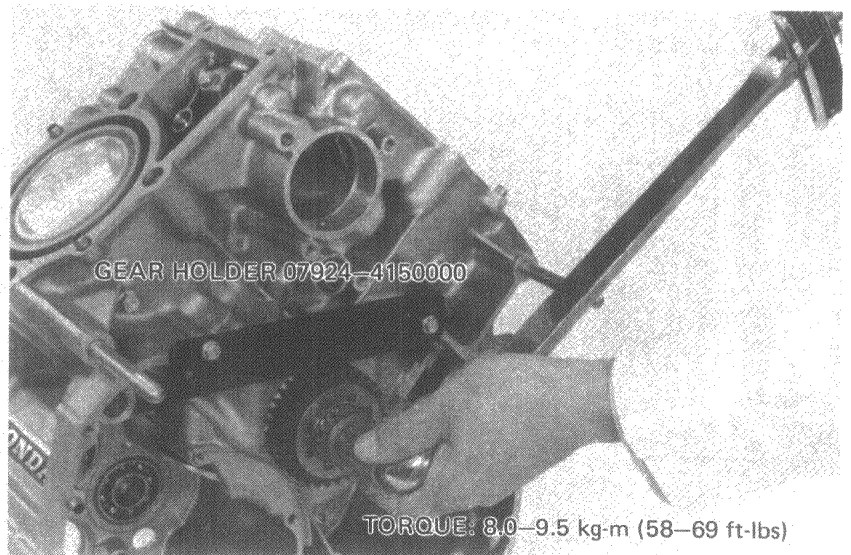





## PISTON INSTALLATION

Clean the piston domes, ring lands, and side faces.

Carefully install the piston rings.

### NOTE

- Do not damage the pistons and piston rings during assembly.
- All rings should be installed with the markings facing up.
- Space the piston ring end gaps 120 degrees apart, avoiding the piston pin and thrust sides.
- Do not align the gap in the oil rings.
- After installing the rings they should be free to rotate.

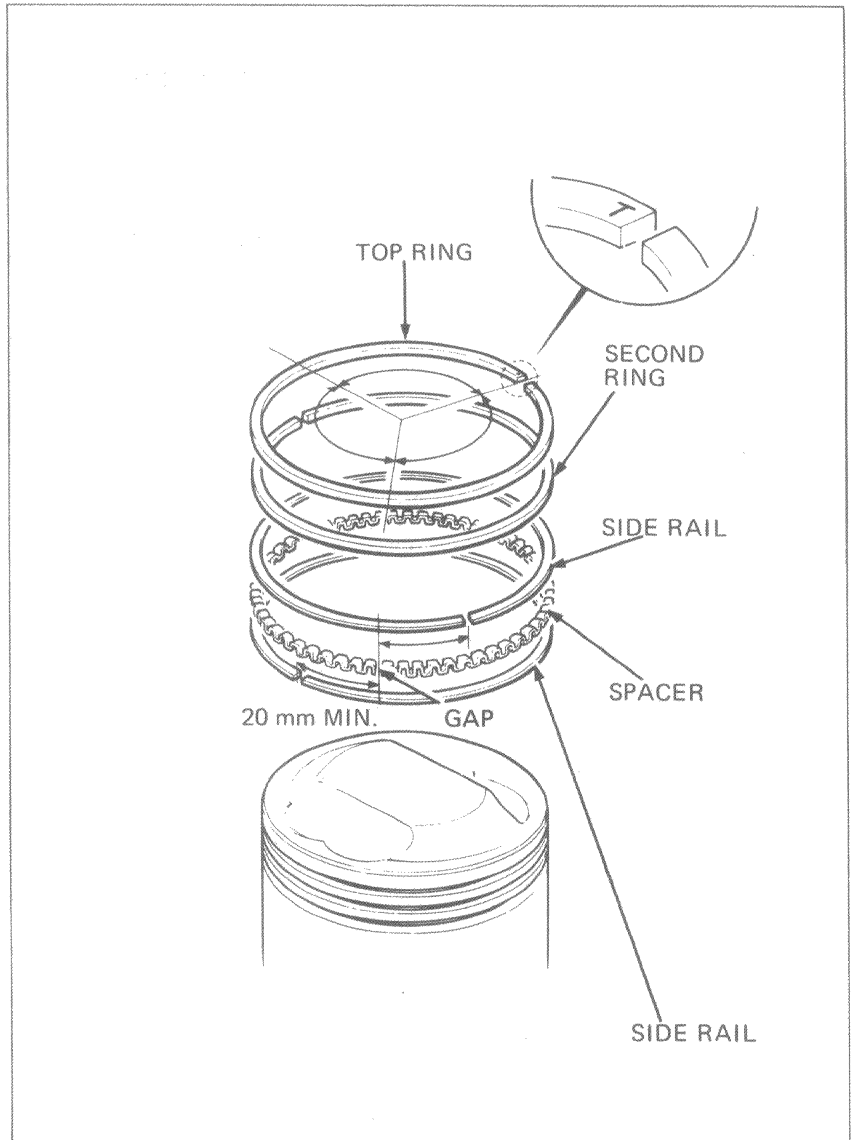

Coat rod small end with molybdenum disulfide grease.

Assemble the pistons and connecting rods with the piston pins and piston pin clips.

### NOTE

- Do not interchange the pistons, piston pins and connecting rods.
- Make sure that the piston pin clips are properly seated.
- Install the piston with the "L" mark on the left and the piston with the "R" mark on the right.

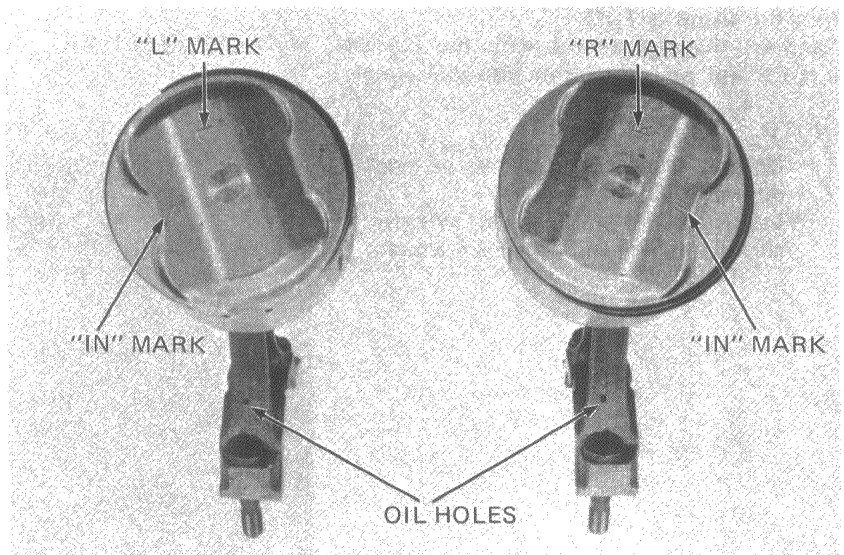



## CONNECTING ROD INSTALLATION

Lubricate the rod bearings with molybdenum disulfide grease.

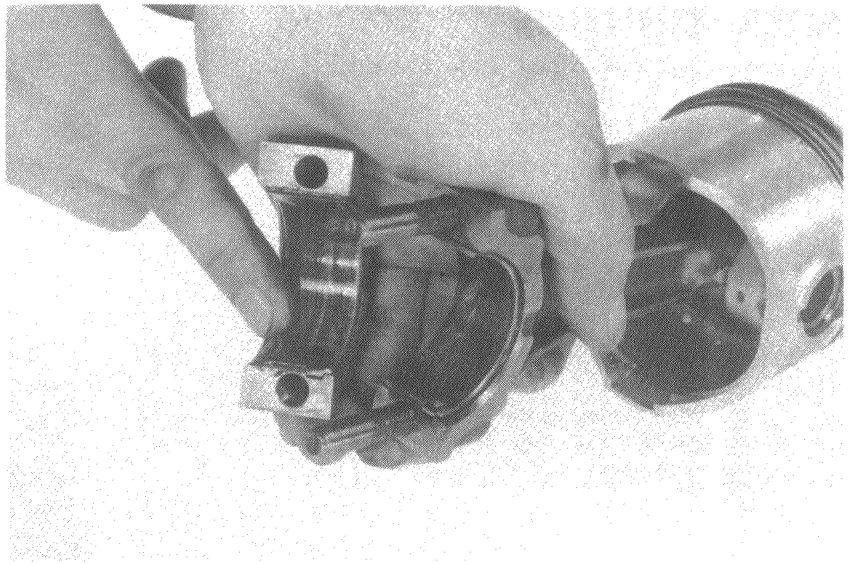

Install the rod assemblies into the cylinders from the top of the engine case.

### NOTE

- The rod assemblies should be installed with the piston "IN" markings to the rear.
- Lubricate the piston ring grooves and cylinder walls with engine oil.

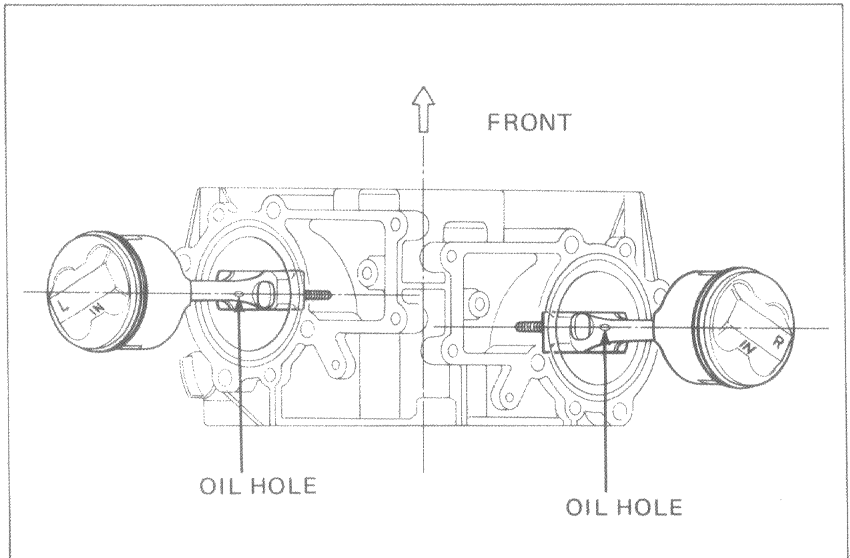

Bring the piston to TDC. Compress the piston rings with the PISTON SLIDER and insert the piston into the cylinder.

PISTON SLIDER  
07755-0010000

### NOTE

- Do not damage the pistons or rings during assembly.
- Insert the piston into the cylinder, aligning the big end with the crankpin.

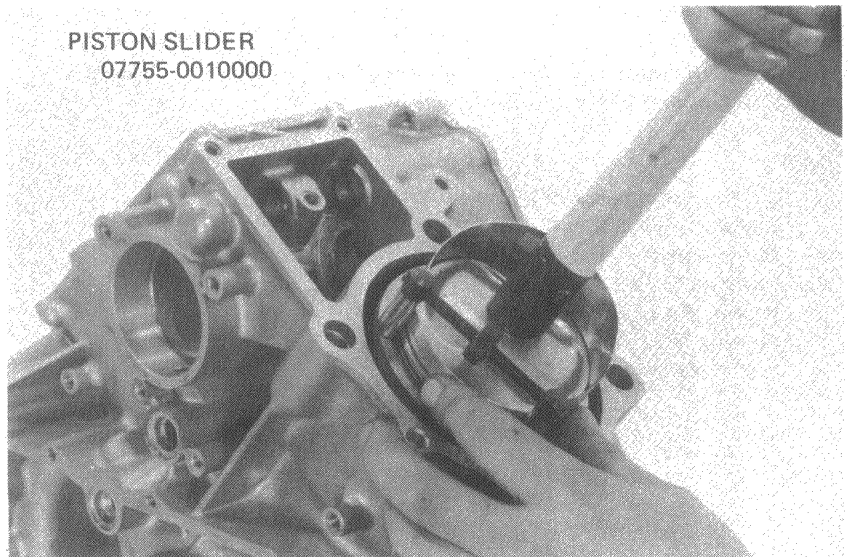





Install the connecting rod caps.

Torque the connecting rod cap bolts.

**TORQUE: 2.8–3.2 kg-m (20–23 ft-lbs)**

**NOTE**

- Be sure the bearing caps are installed in their correct location.
- Turn the crankshaft to make sure the rods rotate freely without binding.
- Torque the bolts evenly in 2–3 steps.

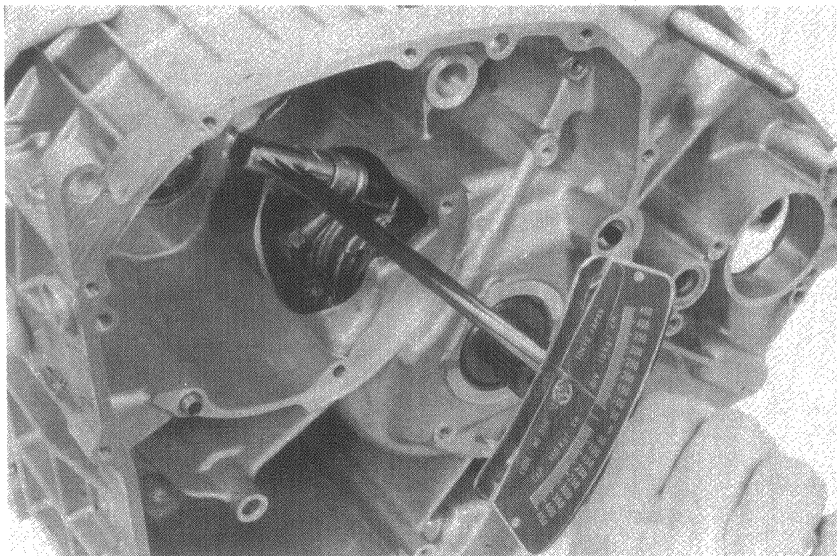

FRONT WHEEL/SUSPENSION



**HONDA**  
**CX500**

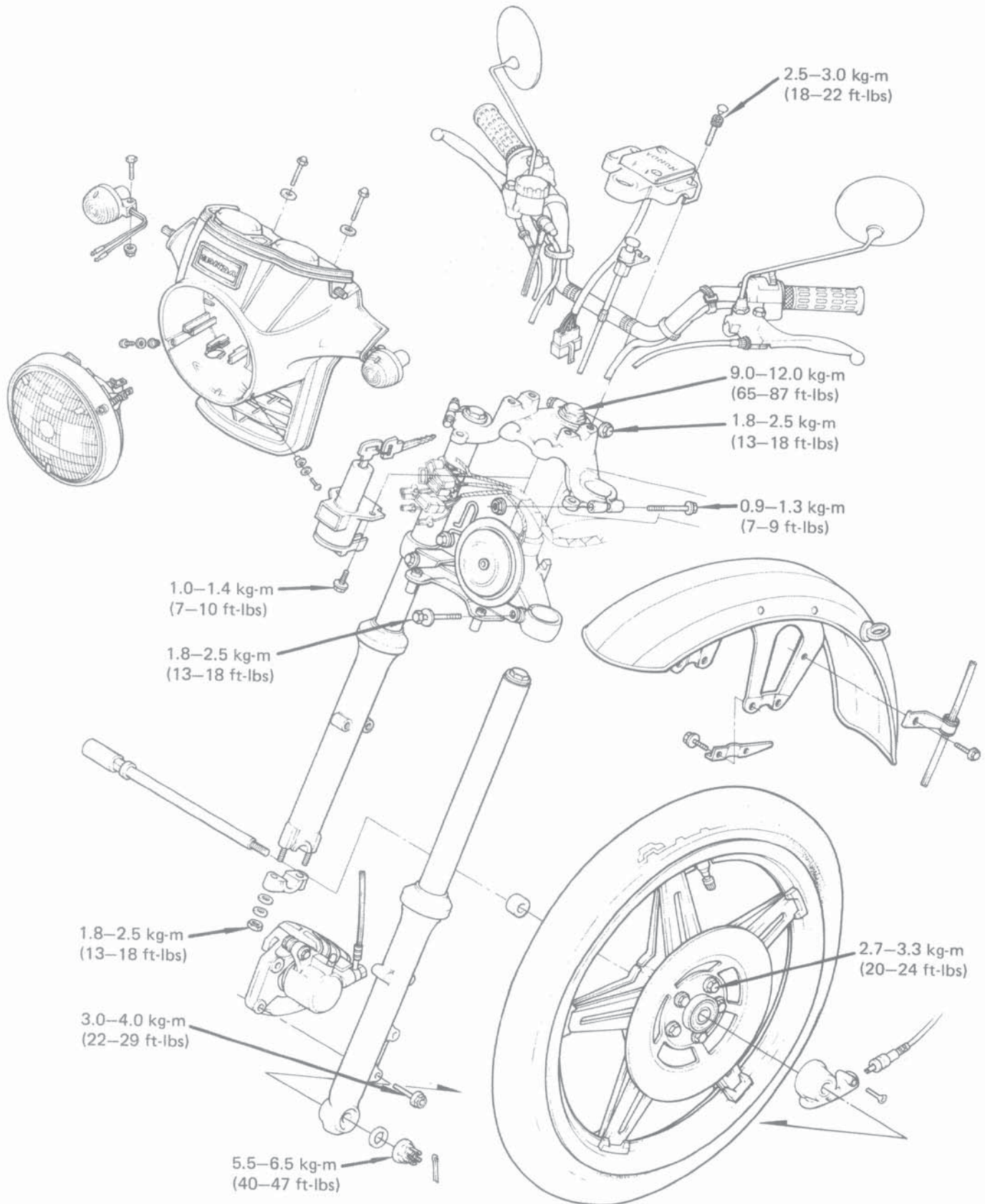





SERVICE INFORMATION	13-1	HANDLEBAR	13-4
TROUBLESHOOTING	13-1	FRONT WHEEL	13-5
HEADLIGHT	13-2	FRONT FORK	13-9
INSTRUMENTS	13-3	STEERING STEM	13-15

## SERVICE INFORMATION

### • WORKING PRACTICE

Do not remove rivets, nuts and pins from the rim, spoke plate and hub, since they cannot be disassembled.

Never ride on the spokes or try to bend the wheel.

Avoid damaging the aluminum alloy rim.

Check that the tire and rim are free from damage as the tire is tubeless.

When removing the tire from the rim, use the special tools "TIRE LEVER" and "RIM PROTECTOR" to prevent damage to the rim.

For tubeless tire repairs, see the "HONDA MOTORCYCLE TUBELESS TIRE REPAIR MANUAL."

### • SPECIAL TOOLS/Common TOOLS

#### Special Tools

TIRE LEVER	07772-0020100
RIM PROTECTOR	07772-0020200
HOLLOW SET WRENCH (6 mm)	07917-3230000
BALL RACE DRIVER (BOTTOM)	07945-3330300
BALL RACE DRIVER (TOP)	07946-3290000
STEERING STEM DRIVER	07946-3710600
BALL RACE REMOVER	07953-3330000

#### Common Tools

PIN SPANNER	07702-0010000
LOCK NUT WRENCH SOCKET (32 x 30 mm)	07716-0020400
EXTENSION BAR	07716-0020500
BEARING DRIVER HANDLE (A)	07749-0010000
BEARING DRIVER OUTER (42 x 47 mm)	07746-0010300
BEARING DRIVER PILOT (15 mm)	07746-0040300
FRONT FORK OIL SEAL DRIVER BODY	07747-0010100
FRONT FORK OIL SEAL ATTACHMENT (D)	07747-0010500

### • SPECIFICATIONS

ITEM		STANDARD	SERVICE LIMIT
Axle shaft runout		—	0.2 mm (0.008 in.)
Front wheel rim runout	Radial	—	2.0 mm (0.08 in.)
	Axial	—	2.0 mm (0.08 in.)
Front cushion spring free length	Upper	98.2 mm (3.87 in.)	90.1 mm (3.55 in.)
	Lower	461.7 mm (18.18 in.)	449.5 mm (17.70 in.)
Front fork tube bend		—	0.2 mm (0.008 in.)
Front fork oil capacity		135-140 cc (4.5-4.7 oz.)	—

## TROUBLESHOOTING

#### Hard Steering

1. Steering stem nut too tight
2. Faulty steering stem bearings
3. Damaged steering stem ball race and/or cone race
4. Insufficient tire pressure

#### Steers to One Side or Does Not Track Straight

1. Unbalanced right and left shock absorbers
2. Bent front forks
3. Bent front axle; wheel installed incorrectly.

#### Front Wheel Wobbling

1. Distorted rim

#### 2. Worn front wheel bearing

3. Distorted spokes
4. Faulty tire
5. Axle not tightened properly

#### Soft Suspension

1. Weak fork spring
2. Insufficient fluid in front forks

#### Hard Suspension

1. Incorrect fluid weight in front forks

#### Front Suspension Noise

1. Slider binding
2. Insufficient fluid in forks
3. Loose front fork fasteners





## HEADLIGHT

### • HEADLIGHT CASE REMOVAL

Remove the headlight and disconnect all wires at their couplers and connectors.

#### NOTE

Hold the connectors with pliers to prevent the wires from being cut.

Remove the two fork top bridge bolts and remove the headlight case.

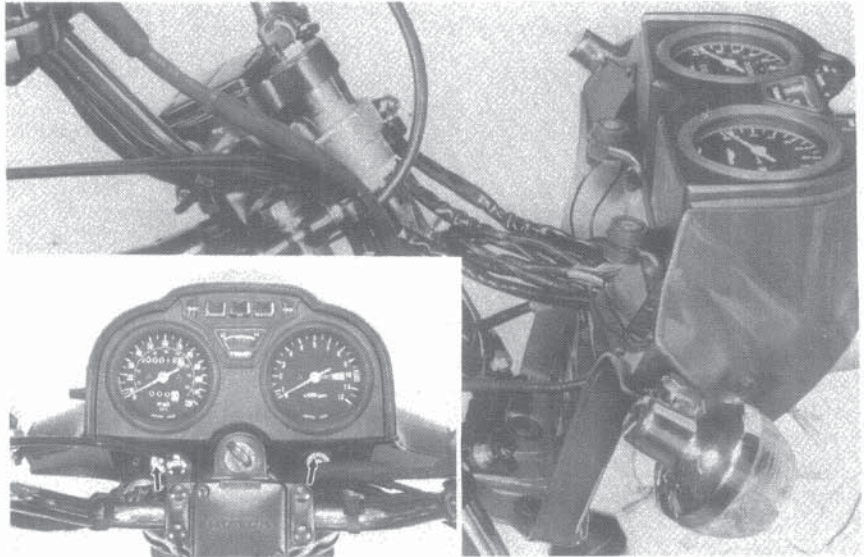

### • WIRING CONNECTION IN HEADLIGHT CASE

Route the wires into the headlight case through the headlight case hole.

Connect the wires color-to-color.

Set each coupler in its correct holder in the headlight case.

WIRING (Section 1).

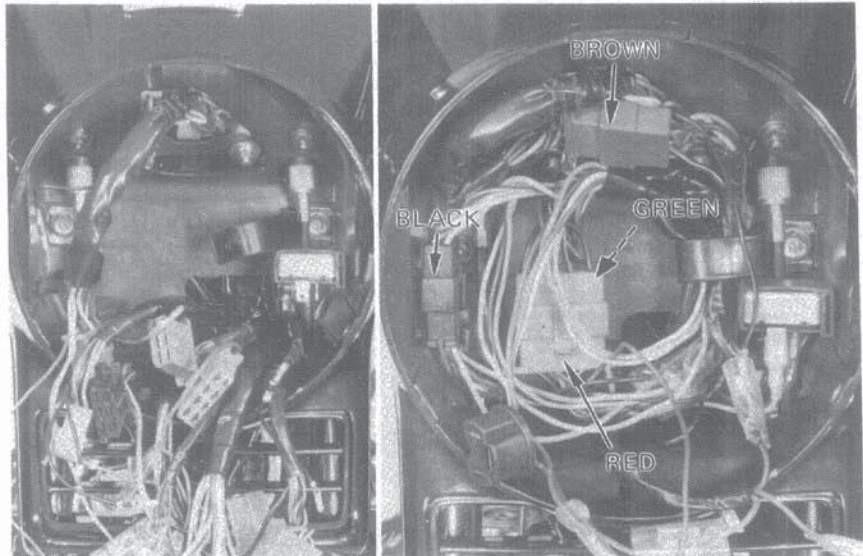

### • HEADLIGHT INSTALLATION

Place the headlight upper hook over the headlight case and secure the headlight with two lower screws.

Check the headlight aim and adjust by screws (A), (B) if necessary.

#### NOTE

Check each component for operation after assembling.

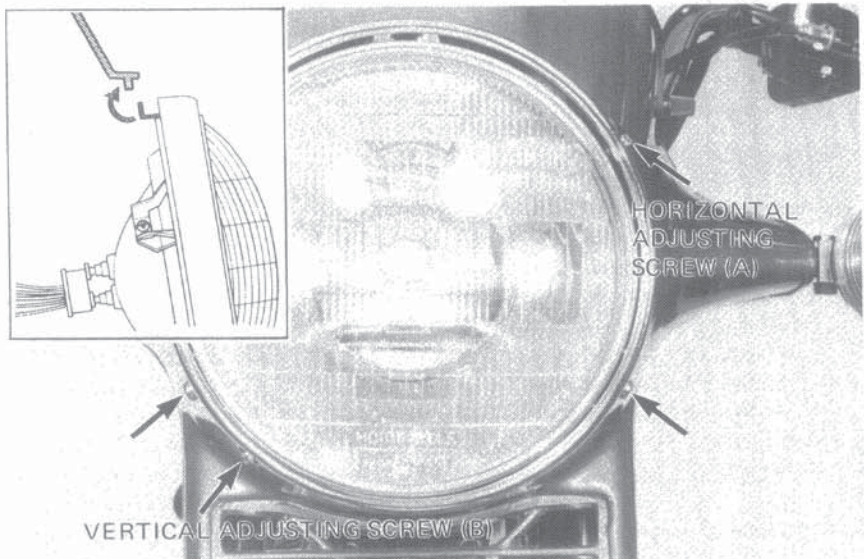





## INSTRUMENTS

### • CLUSTER DISASSEMBLY

Remove the headlight. Disconnect the meter cables and each applicable wire harness coupler. Separate the meters from the meter panel by removing the two nuts.

The meter lamps can be replaced under the above condition.

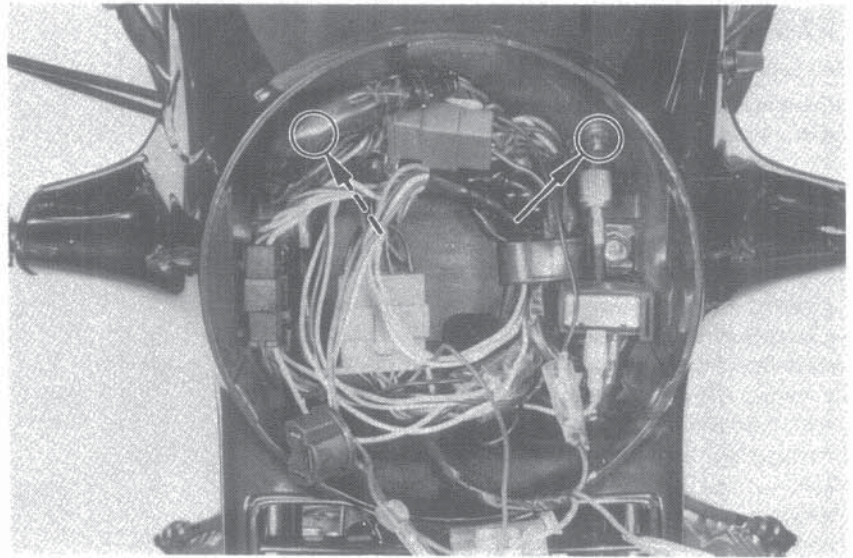

### • INDICATOR LAMP REPLACEMENT

After installing a new bulb, check for continuity. If the bulb does not light, inspect the wiring for open or short circuits.

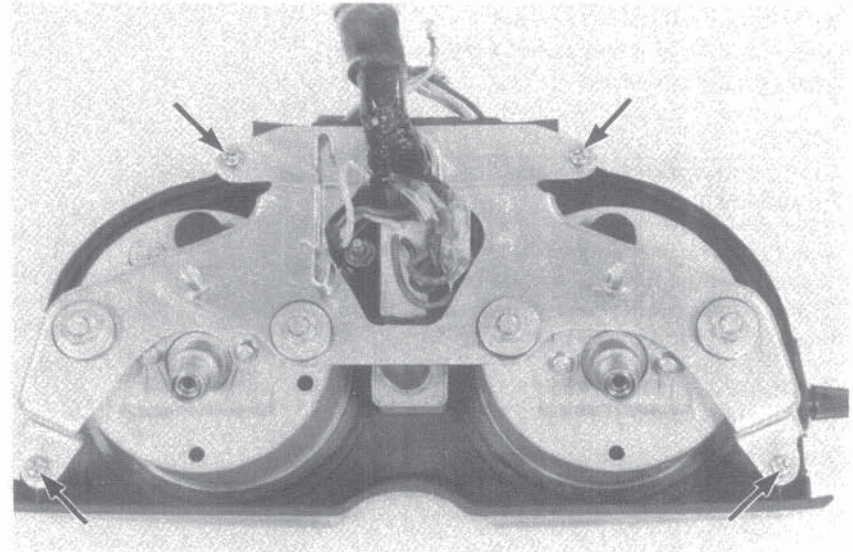

### • METER DISASSEMBLY

To replace a meter, it is necessary to separate the cluster.

Remove the set plate and cable.

### • METER ASSEMBLY

Connect the water temperature gauge wires as shown.

#### NOTE

Install the meter seal rubber properly.

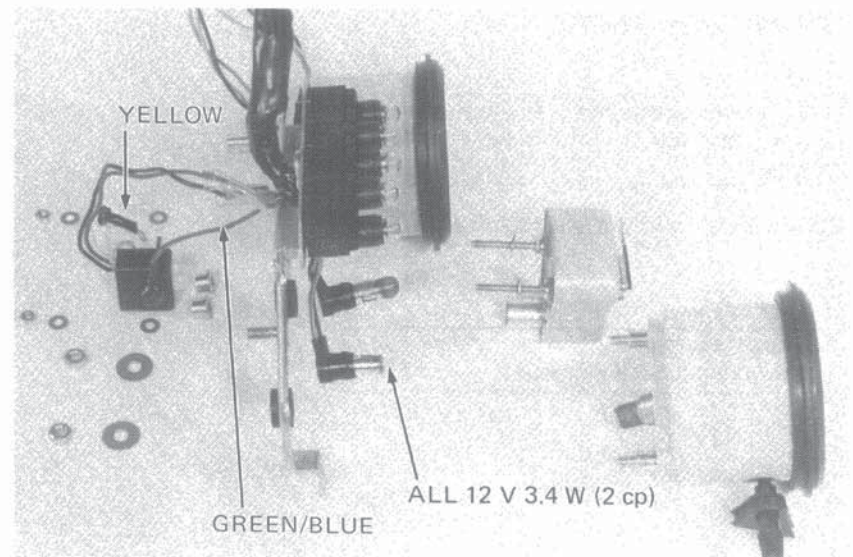





## HANDLEBAR

### • HANDLEBAR REMOVAL

Disconnect the front brake stoplight switch wires and remove the master cylinder.

#### NOTE

Do not loosen the brake hose unless necessary.

Loosen the two screws attaching the throttle grip switch housing.

Disconnect the clutch switch wires.

Remove the two screws holding the left grip switch housing.

Remove the switch wire bands.

Remove the handlebar upper holder and the handlebar with the throttle grip and switch housing.

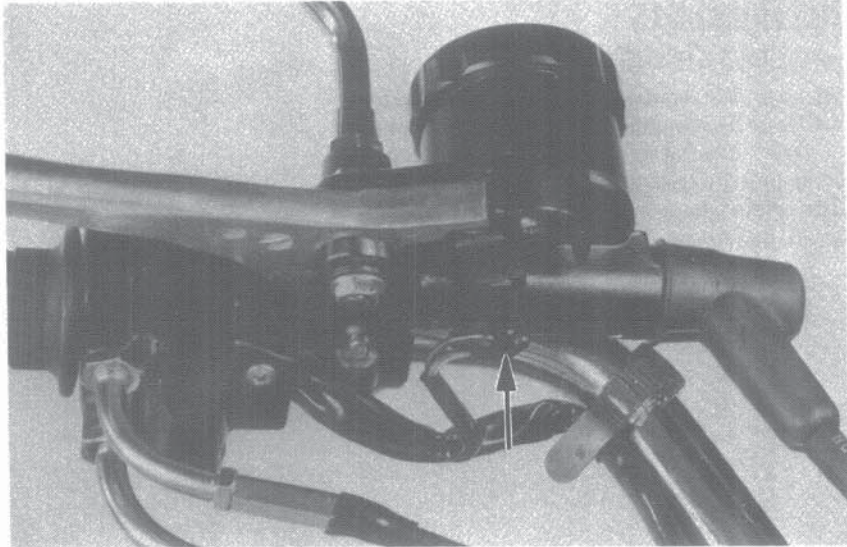

### • HANDLEBAR INSTALLATION

Installation of the handlebar is essentially the reverse order of removal.

#### NOTE

Coat the throttle grip area of the handlebar with grease.

Align the punch marks on the handlebar with the splits of the fuse box and switch housing.

Tighten the forward screw first, then tighten the rear screws to the same torque.

#### TORQUE SPECIFICATION:

2.5–3.0 kg-m (18–22 ft-lbs)

Connect the clutch switch wires.

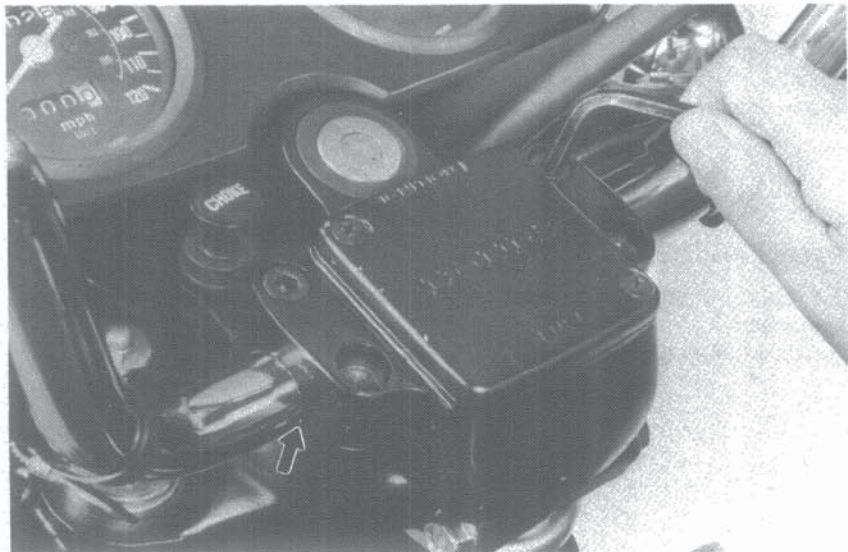

Install the master cylinder.

#### NOTE

Align the punch mark on the handlebar with the lug of the master cylinder holder.

Connect the front brake stoplight switch wires.

#### NOTE

Install the master cylinder holder with the wire relief facing down.

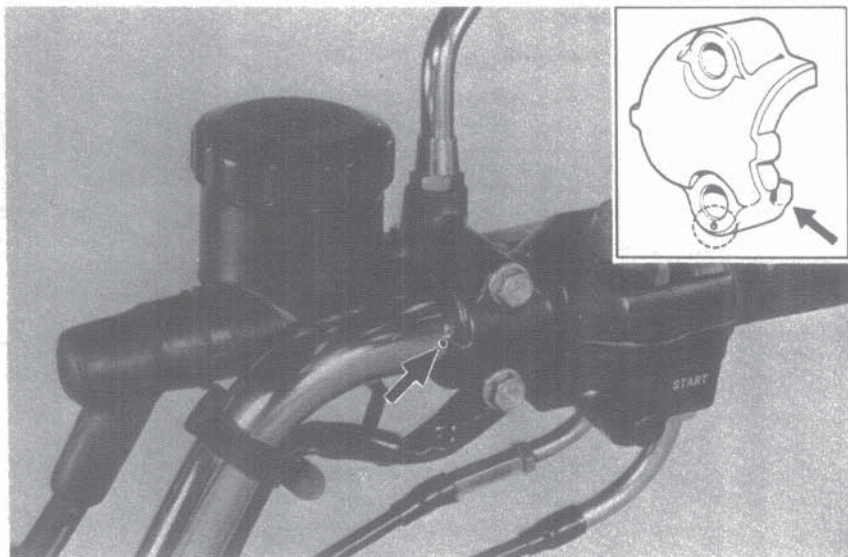





## FRONT WHEEL

### • FRONT WHEEL REMOVAL

Raise the front wheel off the ground by placing a block or safety stand under the engine.

Disconnect the speedometer cable from the speedometer gearbox.

Remove the cotter pin and loosen the axle nut.

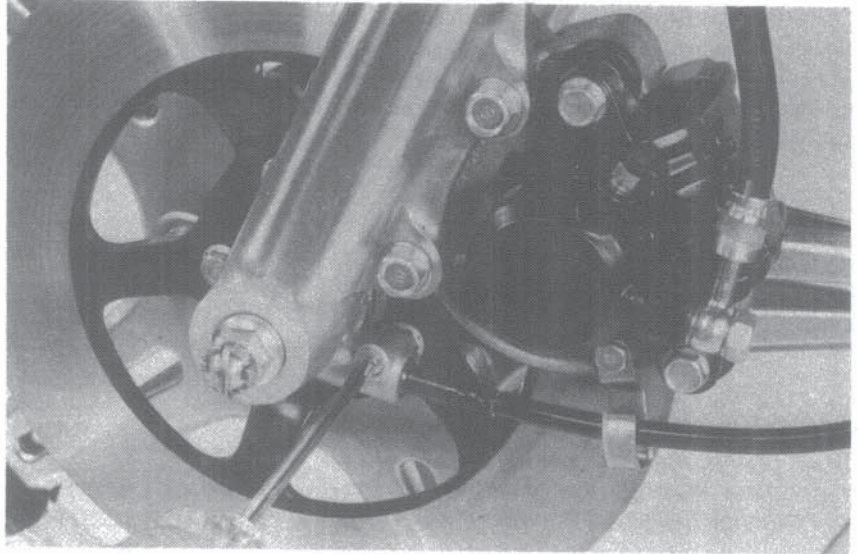

Remove the axle holder from the fork end. Withdraw the axle and remove the wheel.

### NOTE

Do not operate the front brake lever after removing the front wheel. To do so will cause difficulty in refitting the brake disc between the brake pads.

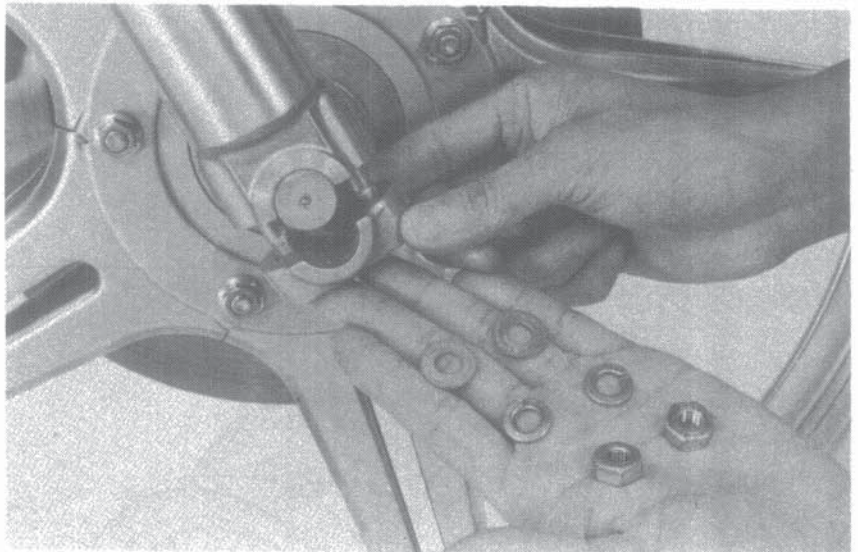

### • AXLE INSPECTION

Set the axle in V blocks and measure the runout. The actual runout is 1/2 of TIR (Total Indicator Reading).

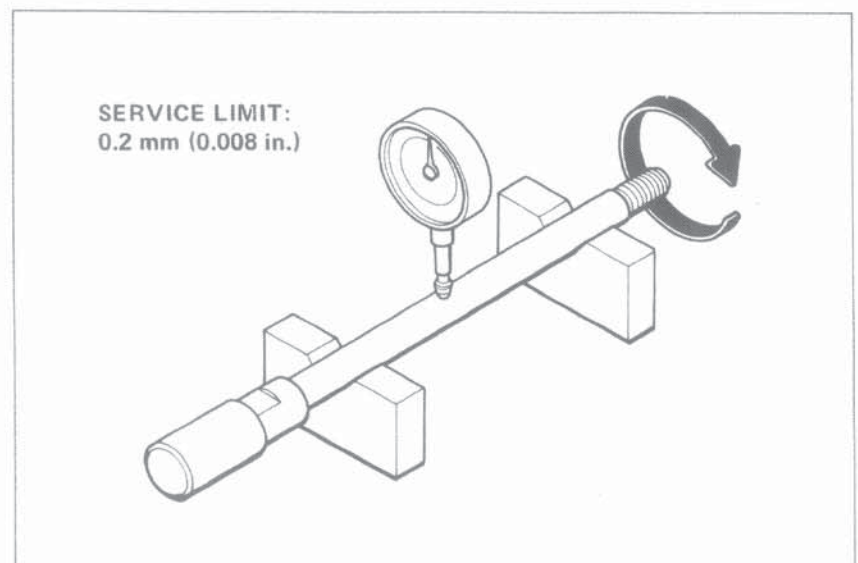



**FRONT WHEEL/SUSPENSION**

• **WHEEL BEARING INSPECTION**

Check the wheel bearing play by placing the wheel in a truing stand and spinning the wheel by hand. Replace the bearings with new ones if they are noisy or have excessive play.

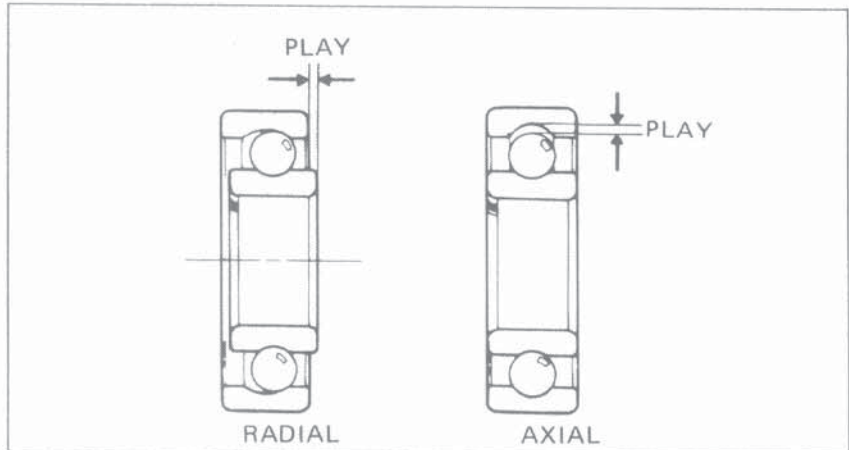

• **WHEEL INSPECTION**

Check the rim runout by placing the wheel in a truing stand. Then spin the wheel by hand, and read the runout using a dial indicator gauge.

**NOTE**

The COMSTAR WHEEL cannot be repaired and must be replaced with a new one if the service limits are exceeded.

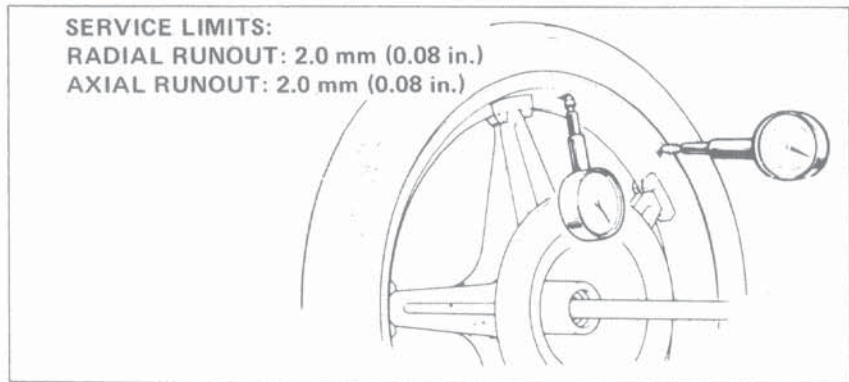

**SERVICE LIMITS:**

**RADIAL RUNOUT: 2.0 mm (0.08 in.)**

**AXIAL RUNOUT: 2.0 mm (0.08 in.)**

• **WHEEL DISASSEMBLY**

Remove the right bearing first.

**NOTE**

Tubeless tires are standard.

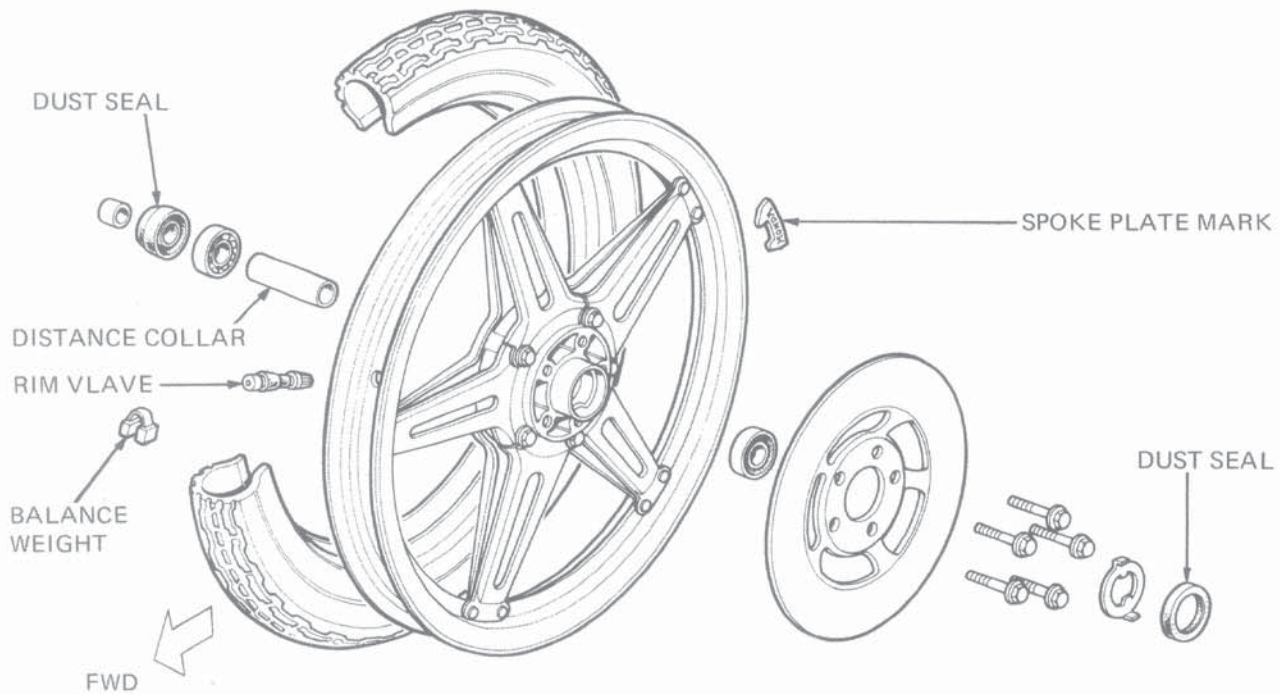





### • FRONT WHEEL ASSEMBLY

Pack all bearing cavities with grease.  
 Drive in the right bearing first.  
 Press the distance collar into place.  
 Drive in the left bearing.

#### NOTE

- Drive the bearing squarely.
- Drive the bearing into position, making sure that it is fully seated and that the sealed side is facing out.

BEARING DRIVE HANDLE A  
 BEARING DRIVER OUTER (42 x 47)  
 BEARING DRIVER PILOT (15)

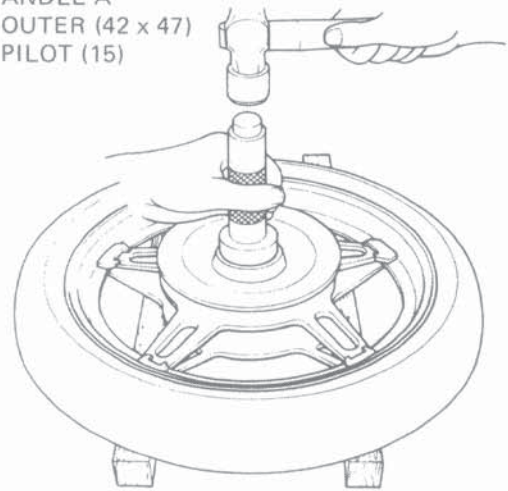

Lubricate the dust seal lip with grease.  
 Install the dust seal and collar in the hub on the right side.

#### NOTE

The spoke plate bolts and nuts require no retightening since they are secured with lock pins. Do not remove these lock pins.

#### CAUTION

Remove all the grease around the outside of the oil seal.

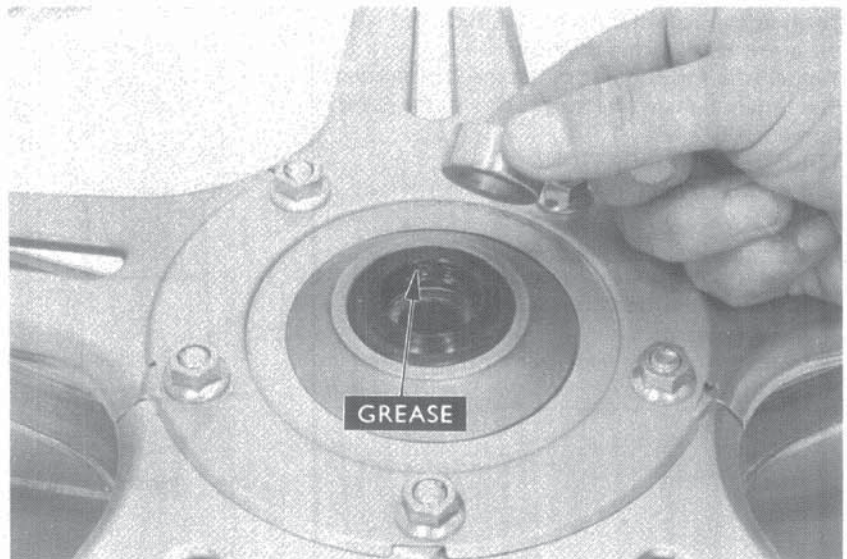

Install the speedometer gear retainer in the hub from the left side.

Lubricate the oil seal lip and install.  
 Disassemble the speedometer gear box and lubricate the gears and sliding faces.  
 Install the speedometer gear in the wheel hub, aligning the speedometer gear box notches with the tangs in the retainer.

#### CAUTION

Remove all the grease around the outside of the oil seal.

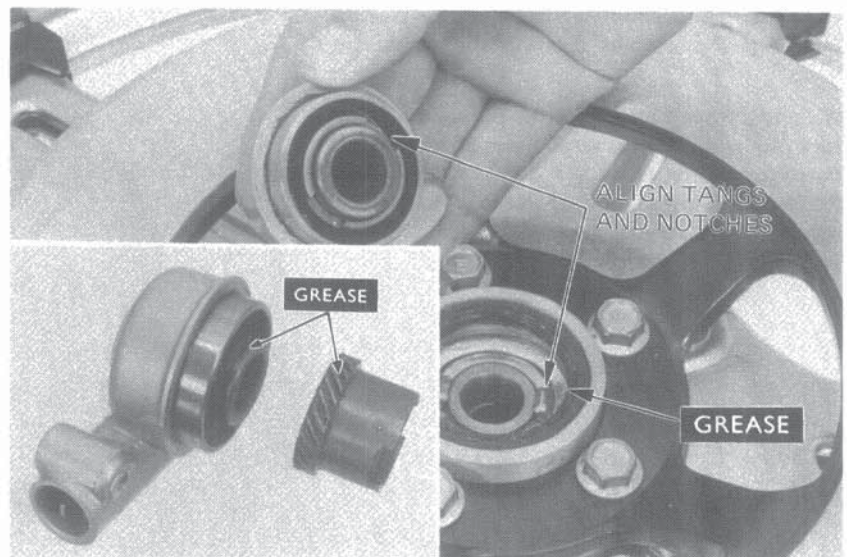





**FRONT WHEEL/SUSPENSION**

● **FRONT WHEEL INSTALLATION**

Insert the axle through the wheel hub from the right side.

Torque the axle nut, noting the installation direction of the speedometer gearbox.

**TORQUE SPECIFICATION:**

5.5–6.5 kg-m (40–47 ft-lbs)

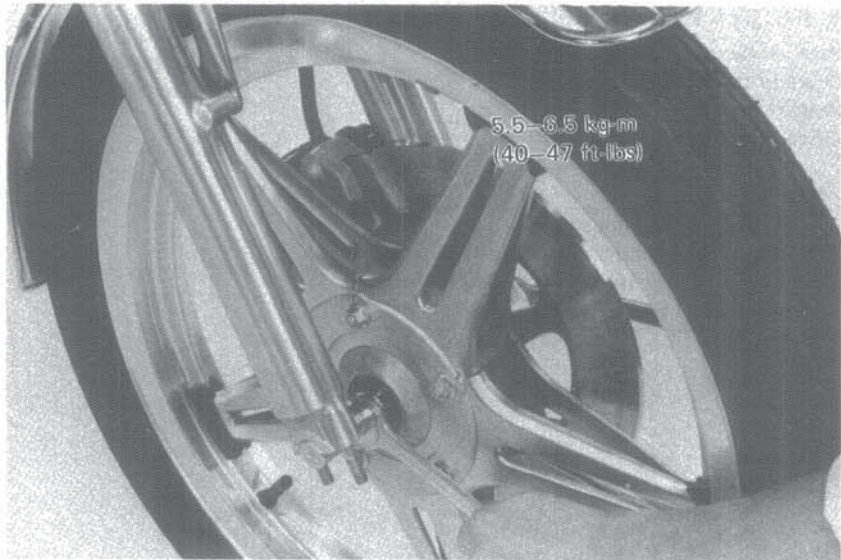

**NOTE**

Install the speedometer gearbox horizontally, being careful not to bend the speedometer cable.

Position the axle holder on the fork end with the arrow mark facing the front.

Tighten the forward nut to the specified torque first, then tighten the rear bolt to the same torque.

**TORQUE SPECIFICATION:**

1.8–2.5 kg-m (13–18 ft-lbs)

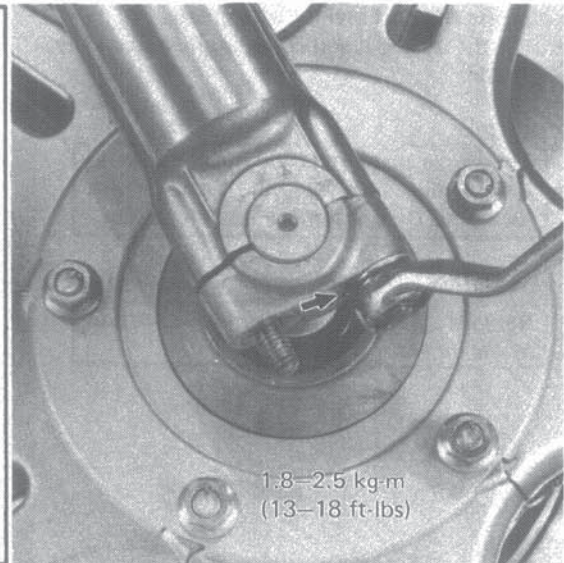
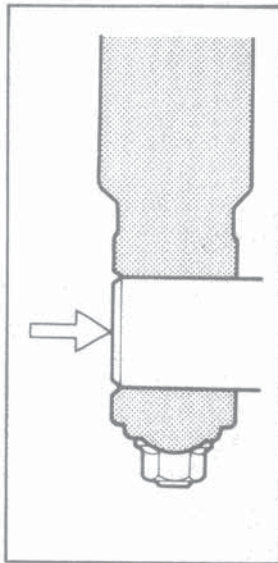

**NOTE**

Place a stand under the engine to remove load from the front fork. Keep the front wheel forward. Align the end of axle with the outside face of fork.

Connect the speedometer cable to the speedometer gearbox while rotating the wheel by hand.

With the front brake applied, pump the front fork up and down several times to check for proper operation.

Recheck the installation of the axle holder and adjust, if necessary.

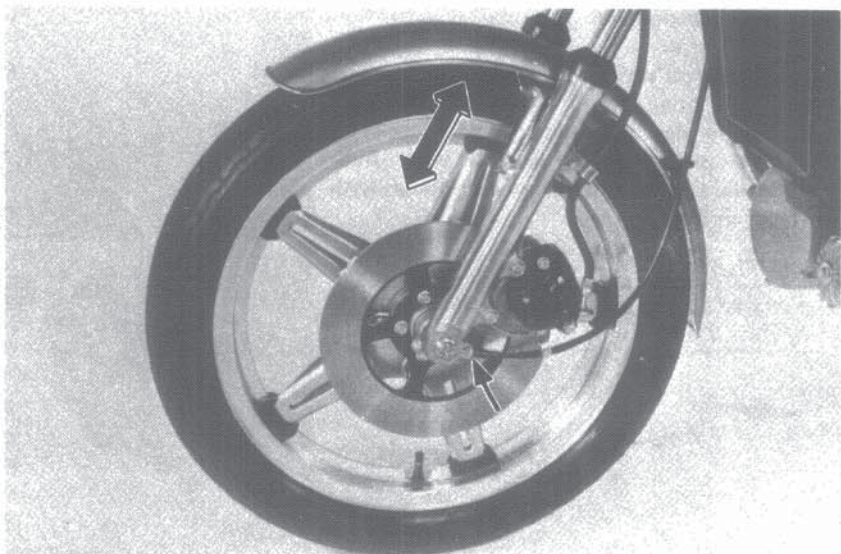





## FRONT FORK

### • FRONT FORK REMOVAL

Remove the front wheel (Page 13-5).  
Remove the brake caliper by unscrewing the attaching bolts.  
Remove the brake hose clamp.

#### NOTE

Do not loosen the brake hose unless necessary.

Remove the front fender.

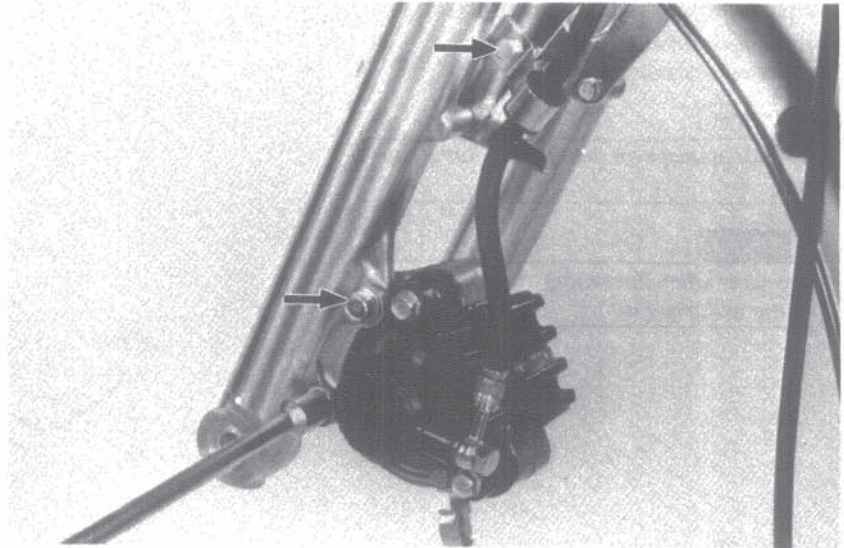

Remove the headlight case (Page 14-3).

#### NOTE

Hold the headlight case with wire.

Loosen the fork bridge bolts.

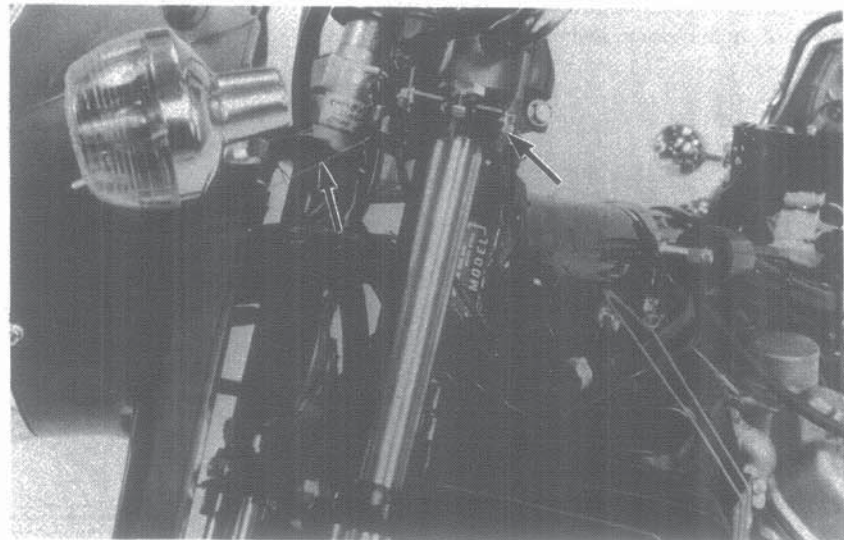

Loosen the front fork steering stem bolts.  
Remove the fork tubes from the bottom fork bridge, rotating them by hand if necessary.

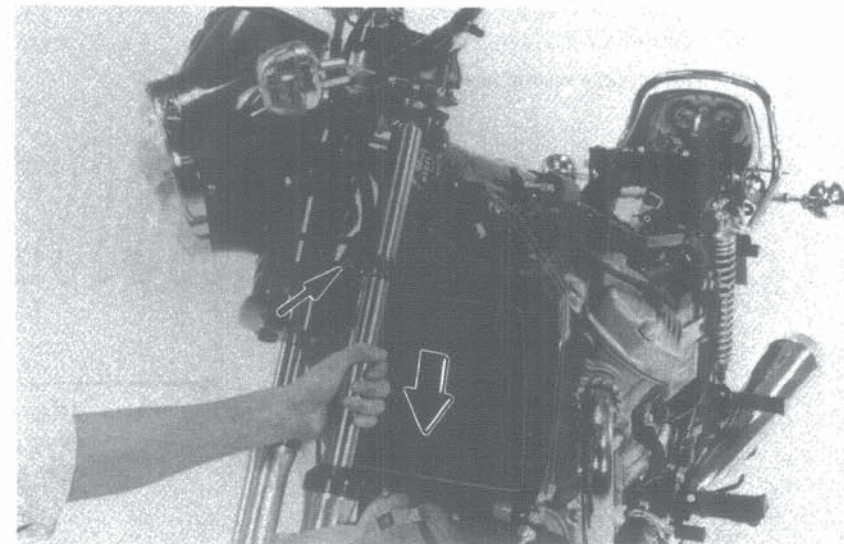



- FRONT FORK DISASSEMBLY

Hold the fork tube in a vise.  
Loosen the fork bolt.

**CAUTION**

*Do not damage or bend the sliding surface.*

**WARNING**

*Use care when loosening the bolt or the spring will pop out.*

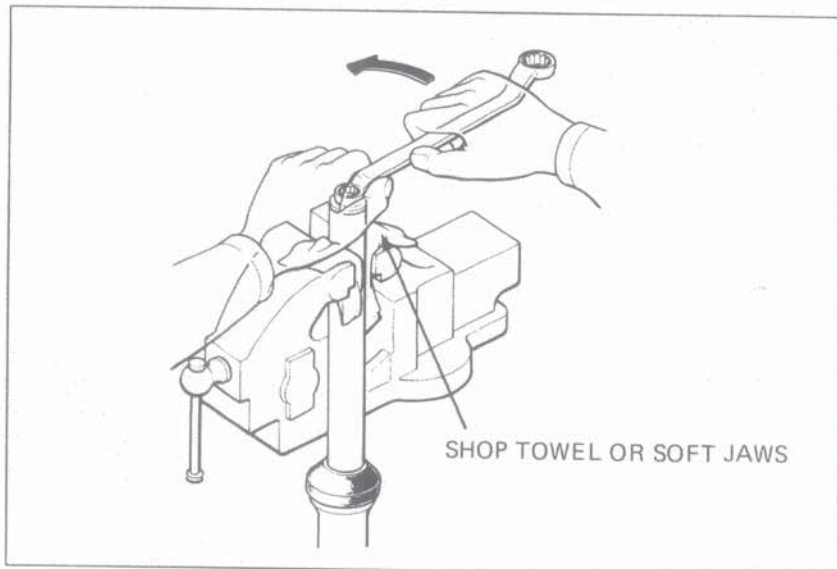

Pour out any remaining fork fluid by pumping the fork up and down several times.

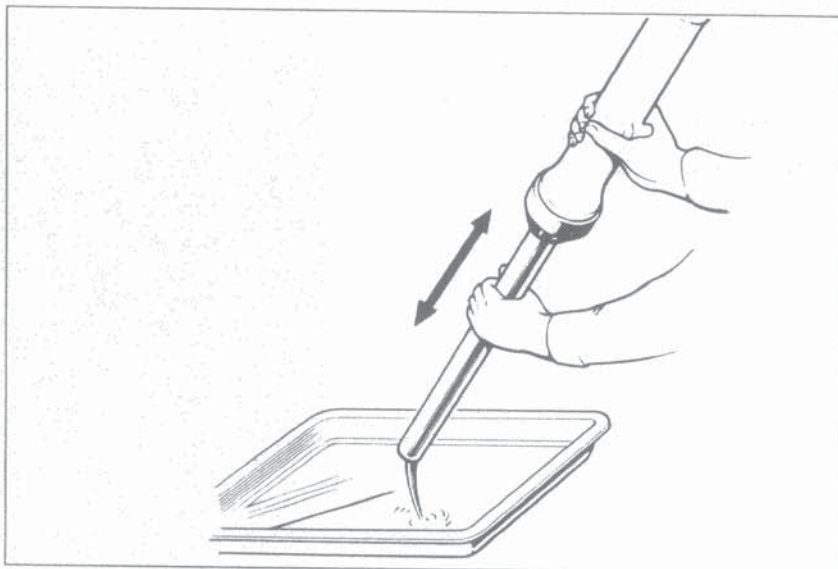

- FRONT FORK SPRING FREE LENGTH INSPECTION

Measure the front damper spring free length.

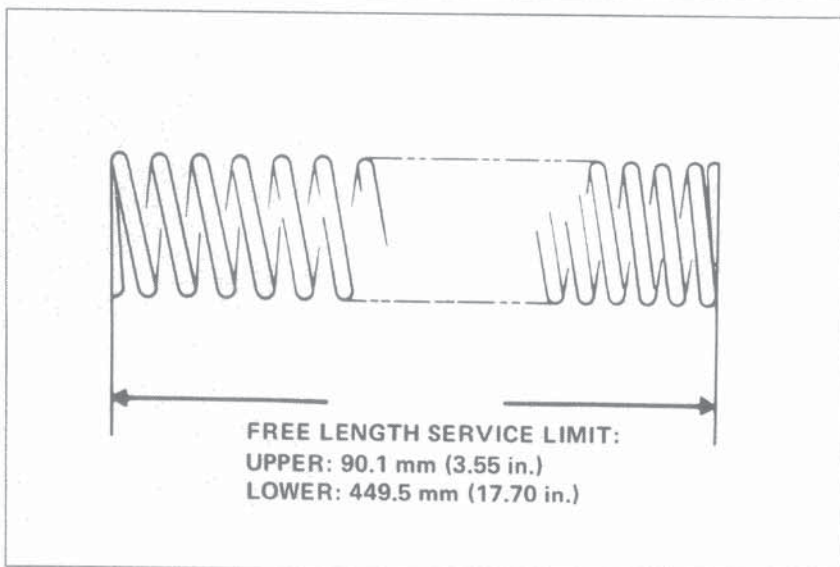





Remove the bolt from the bottom of the fork leg.  
Remove the fork tubes and piston.

### NOTE

- Hold the fork slider in a vice, being careful not to tighten excessively.
- Temporarily install the spring and fork bolt if difficulty is encountered in removing the bolt.

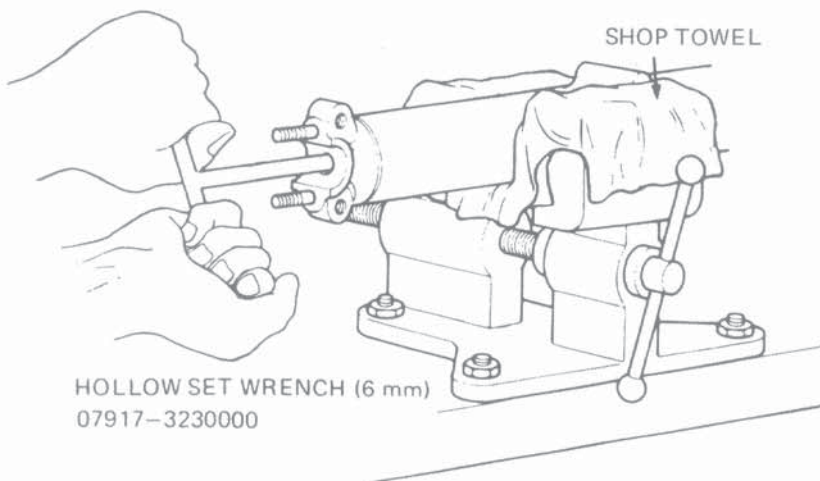

### • OIL SEAL REMOVAL

Remove the snap ring.  
Carefully remove the oil seal with a screwdriver.

### NOTE

- Avoid damaging the inner and outer surfaces of the slider when removing the seal.

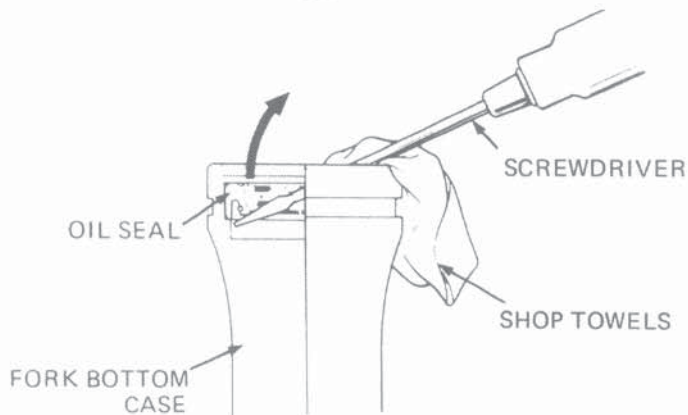

### • FORK TUBE/FORK SLIDER/ PISTON INSPECTION

Check the fork tubes, fork sliders and pistons for score marks, scratches, or excessive or abnormal wear, replacing those which are damaged.

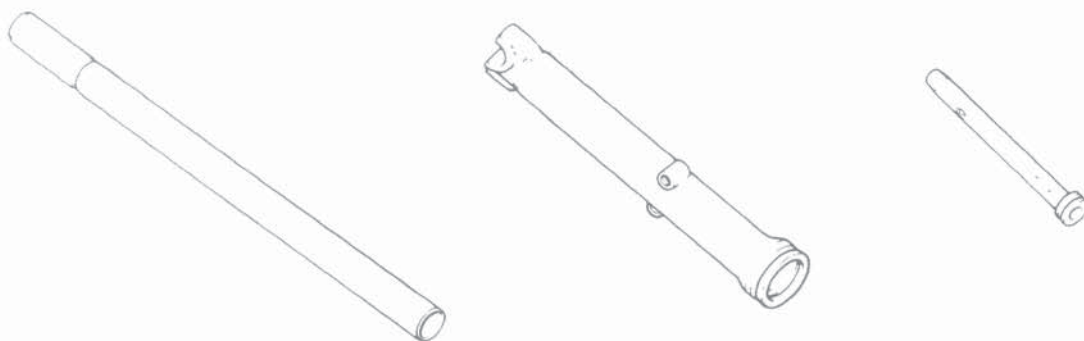

### • FORK TUBE INSPECTION

Set the fork tube in V blocks and read the runout. Take 1/2 TIR to determine the actual runout.

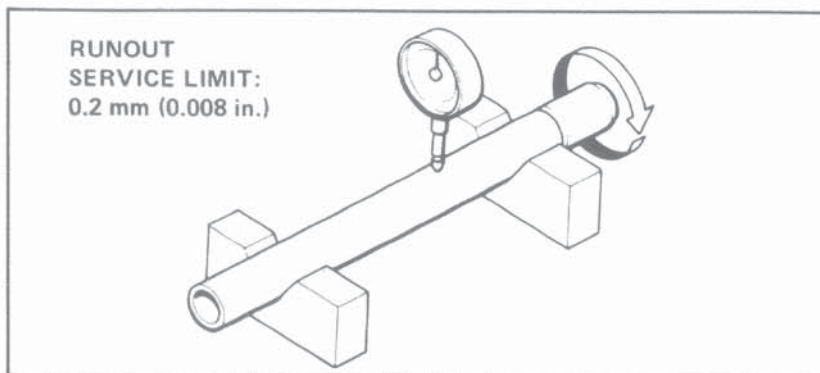



● FRONT FORK ASSEMBLY

NOTE

Clean all parts with solvent and wipe off.

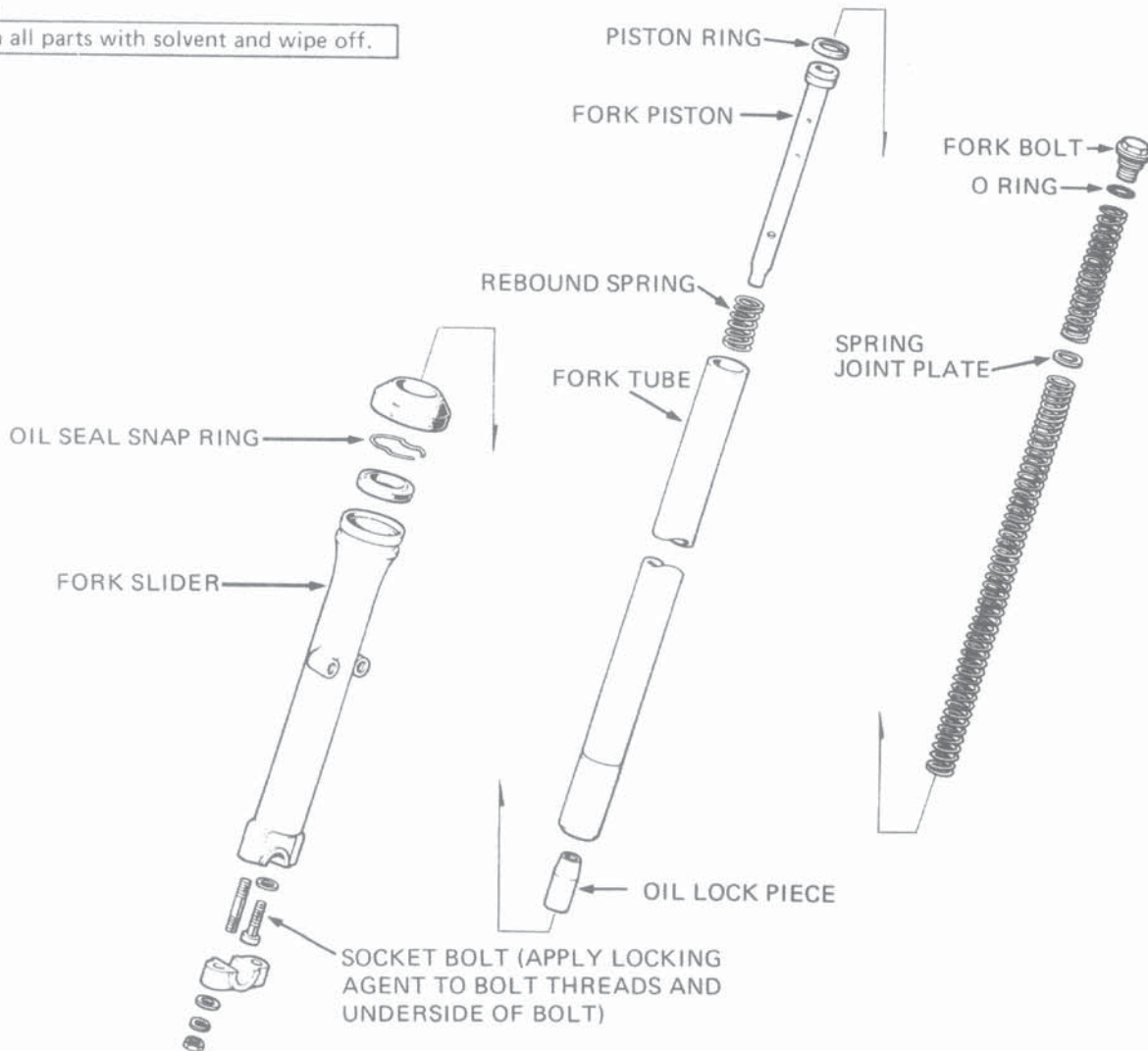

Install the piston and fork tube.  
Apply a locking agent to the bolt threads and underside of the bolt, then torque to specified tension.

NOTE

Do not tighten the fork slider excessively.

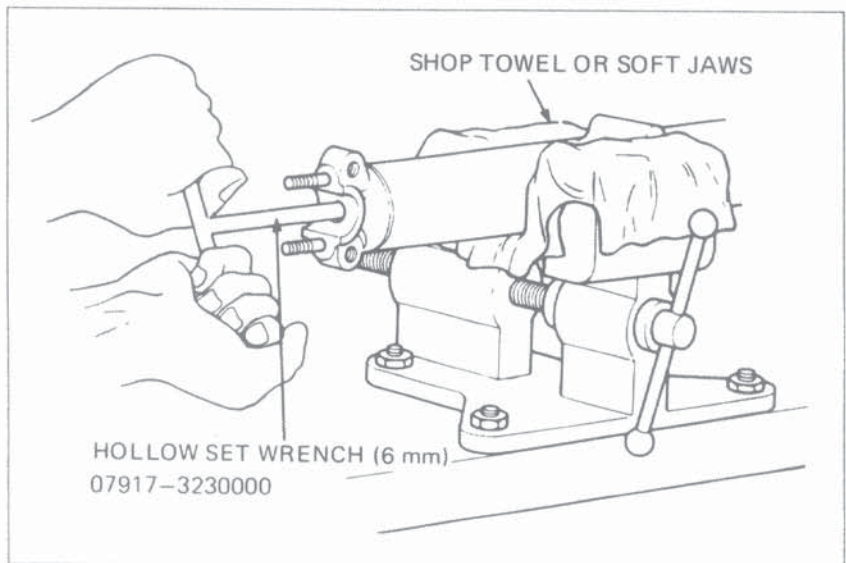





• **OIL SEAL INSTALLATION**

Drive the oil seal into position until the snap ring groove appears.  
Install the snap ring and dust cover.

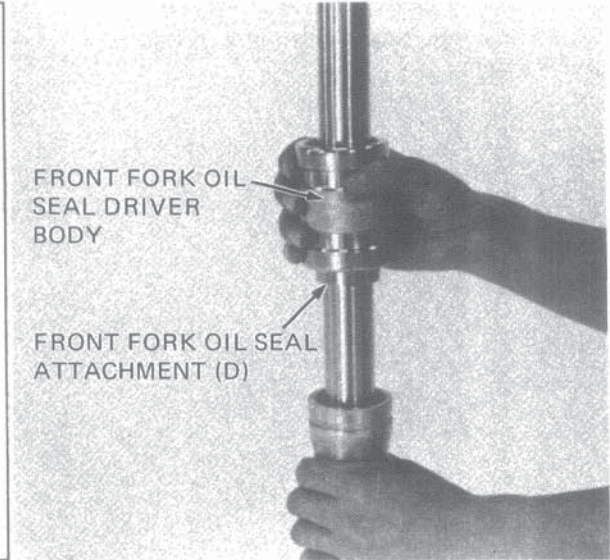
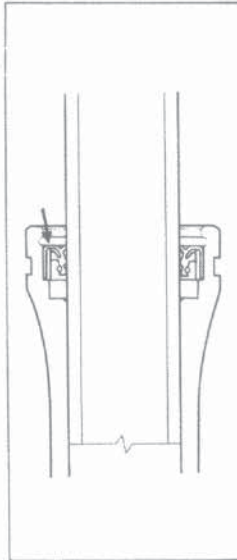

• **FILLING WITH FORK OIL**

Fill each front fork with ATF (Automatic Transmission Fluid).

**NOTE**

Pour the specified amount of ATF. Do not overfill.

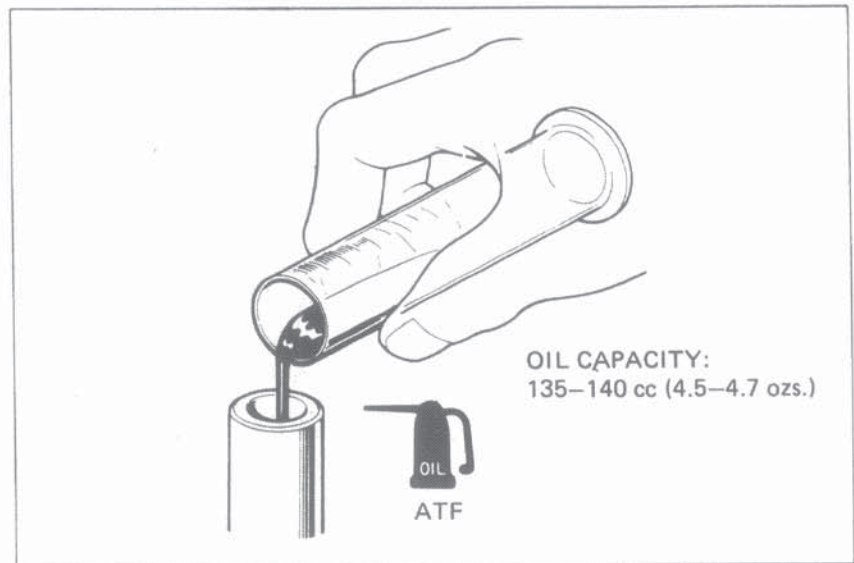

Slide the front fork spring and spring seat into position and tighten the fork bolt.

**NOTE**

- Place the fork tube in soft jaws, avoiding the sliding surface.
- Note the spring direction.

**TORQUE SPECIFICATION:**

4.5-5.5 kg-m (33-40 ft-lbs)

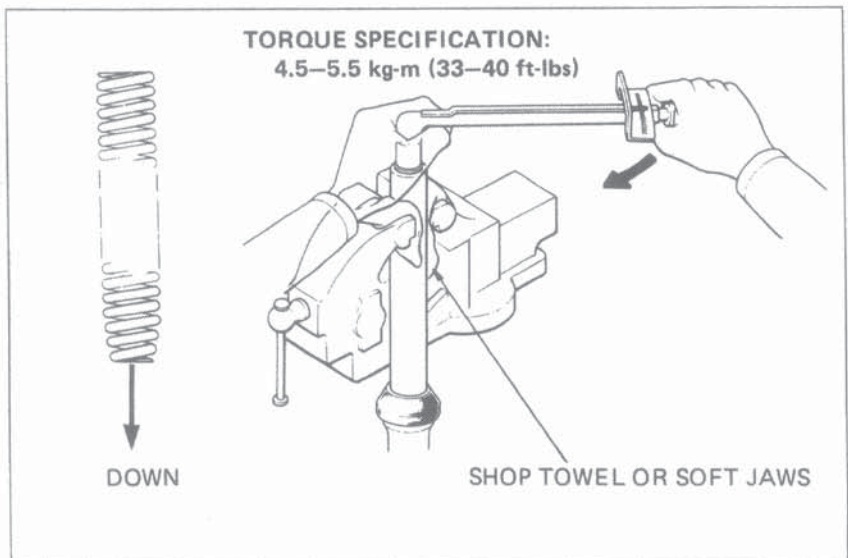



• FRONT FORK INSTALLATION

Install the fork tube in the fork bridge and steering stem.

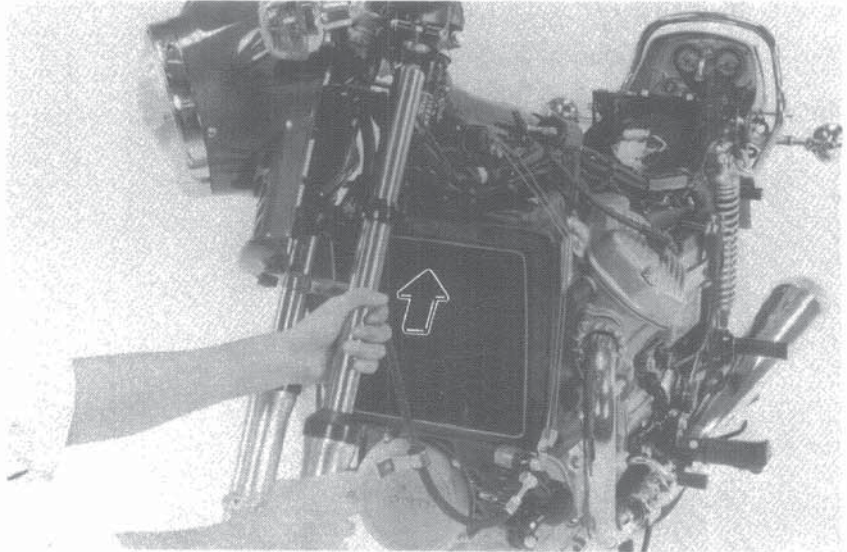

Align the tube top edge flush with the top of the fork bridge.  
Torque the front fork bolt at the steering stem.  
Torque the front fork at the fork top bridge.  
Install the headlight case.

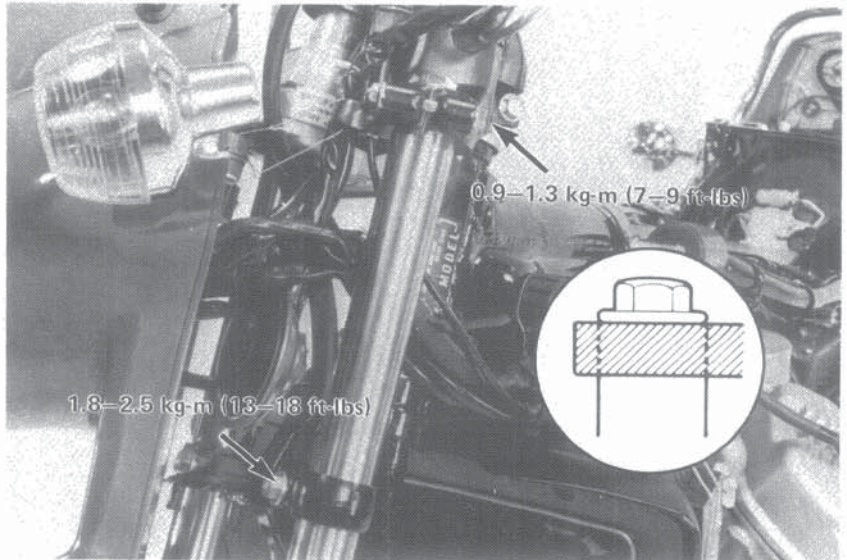

Install the fender.

**NOTE**

Note the fender guide direction.

Install the brake caliper.  
Secure the brake hose. (Page 13-8)  
Install the front wheel. (Page 13-8)

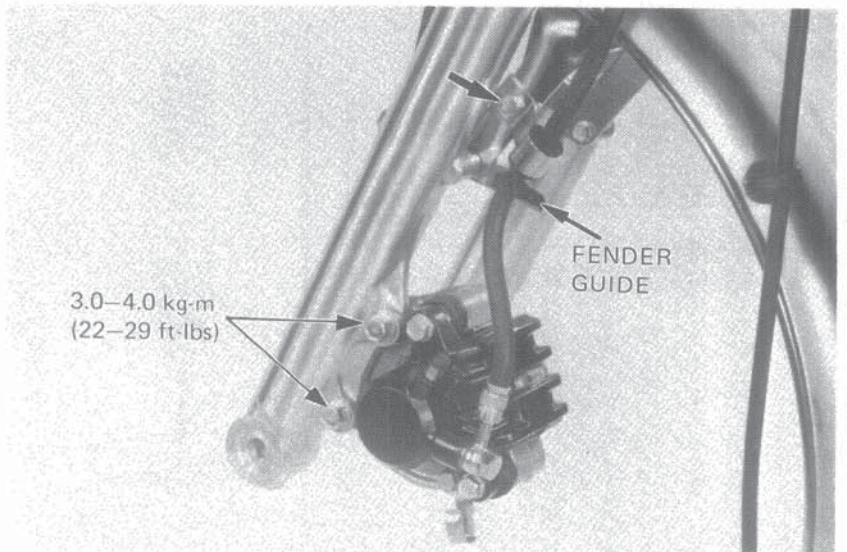





## STEERING STEM

### • STEERING STEM REMOVAL

Remove the headlight case (Page 13-2).  
Remove the handlebars (Page 13-4).

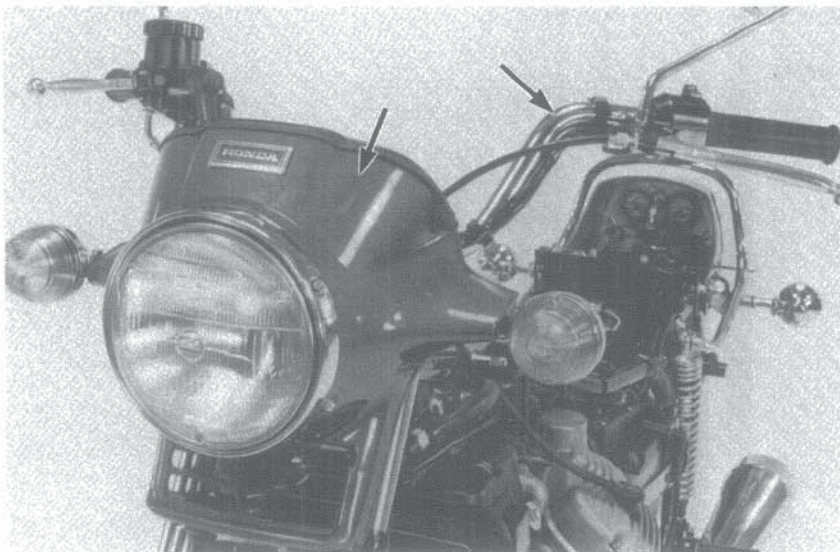

Unscrew the steering stem nut.  
Loosen the fork bridge bolts and stem fixing bolt.  
Remove the fork bridge.

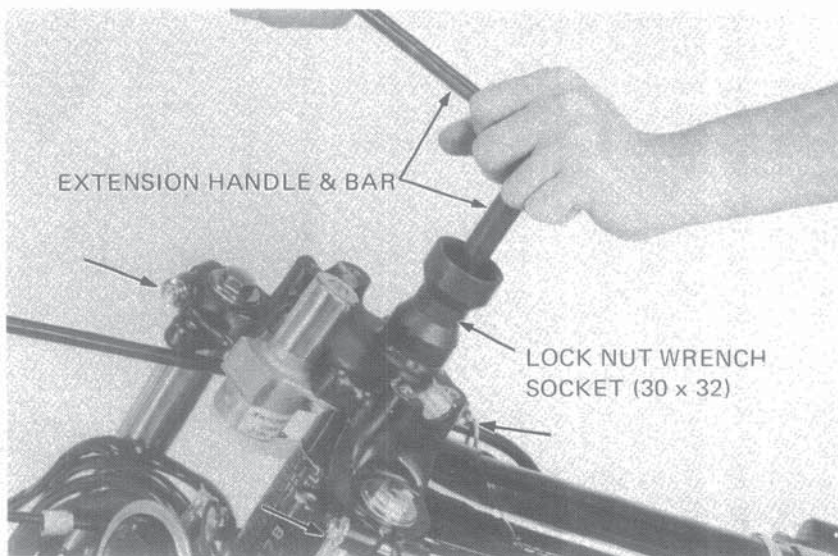

Loosen the steering stem bolts.  
Remove the front fork tubes.

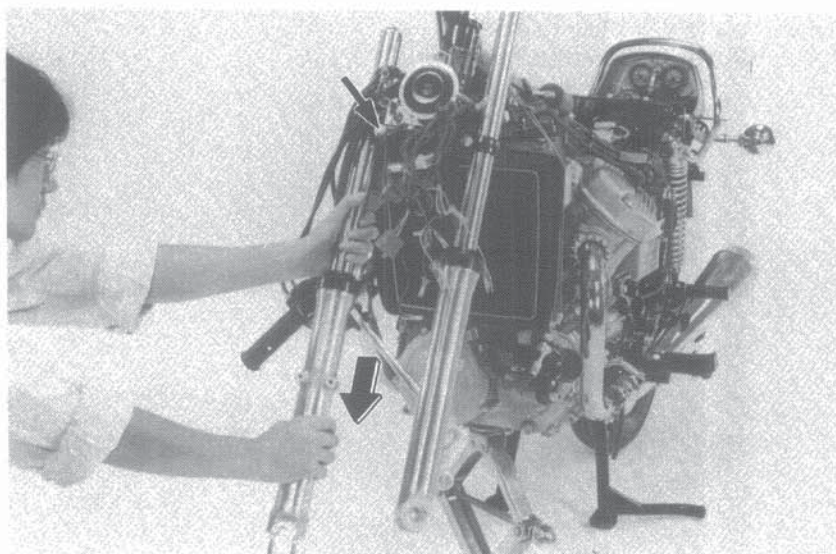





Remove the steering head adjuster.

**NOTE**

Do not allow the steel balls to fall.

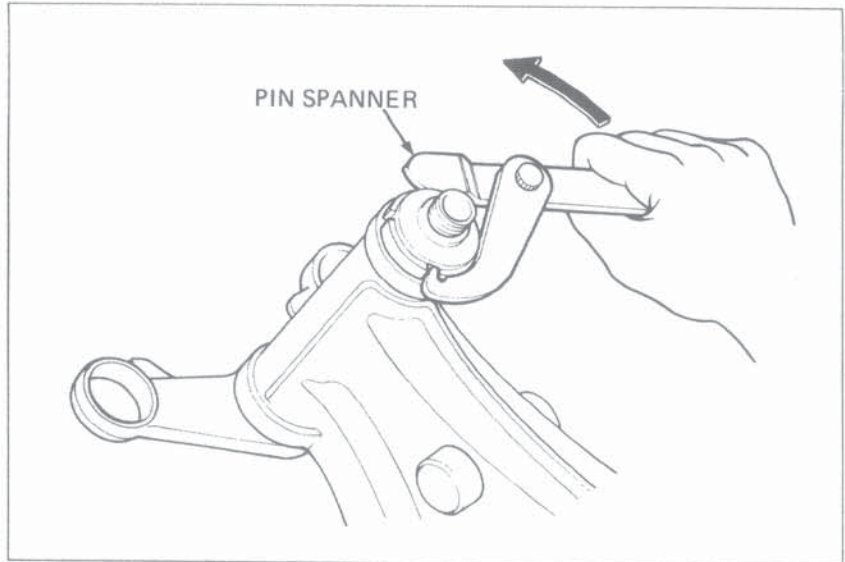

• **BOTTOM CONE RACE REPLACEMENT**

Inspect the bottom cone race for wear or damage and replace if necessary. Remove the bottom cone race with a hammer and a drift.

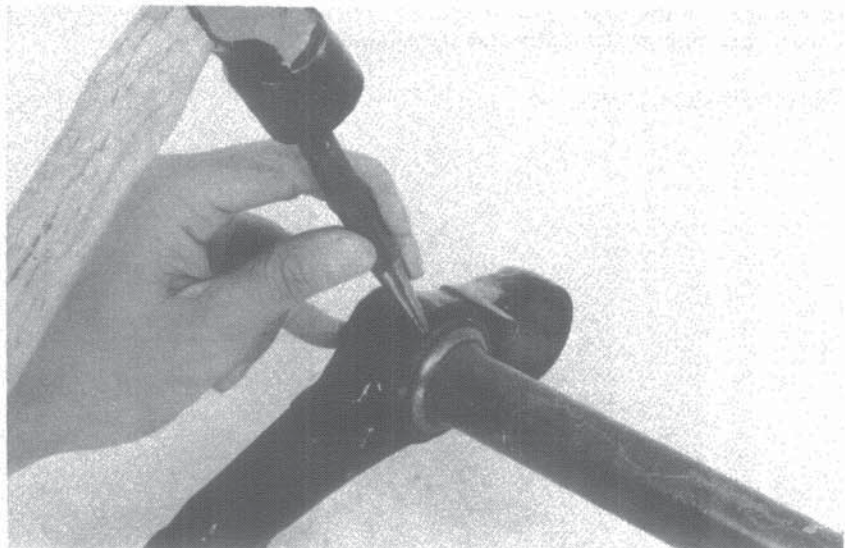

Install a new washer and dust seal. Drive a new bottom cone race into place.

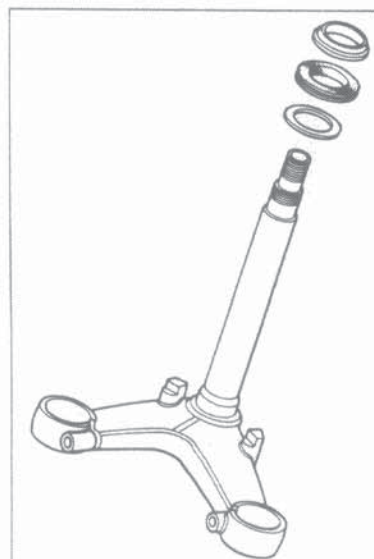

STEERING STEM DRIVER  
07946-3710600





### • BALL RACE REPLACEMENT

Inspect the top and bottom ball races and replace if worn or damaged.  
Drive out the top ball race.  
Drive out the bottom ball race.

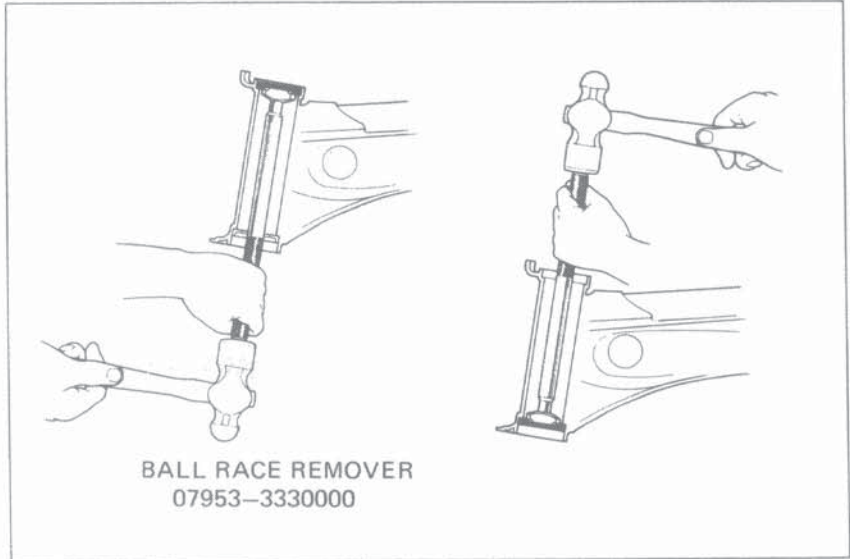

Install a new bottom ball race.  
Install a new top ball race.

#### NOTE

- Drive the ball races squarely.
- Drive the ball races in until they seat.

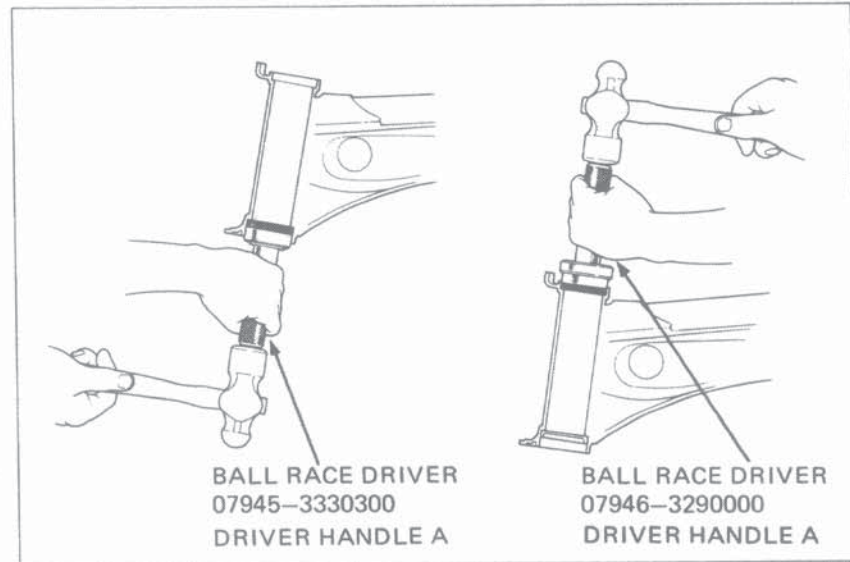

### • STEERING STEM INSTALLATION

Grease the top race and install 18 ball bearings.  
Grease the lower cone race and install 19 ball bearings.

#### NOTE

Do not allow the balls to fall.

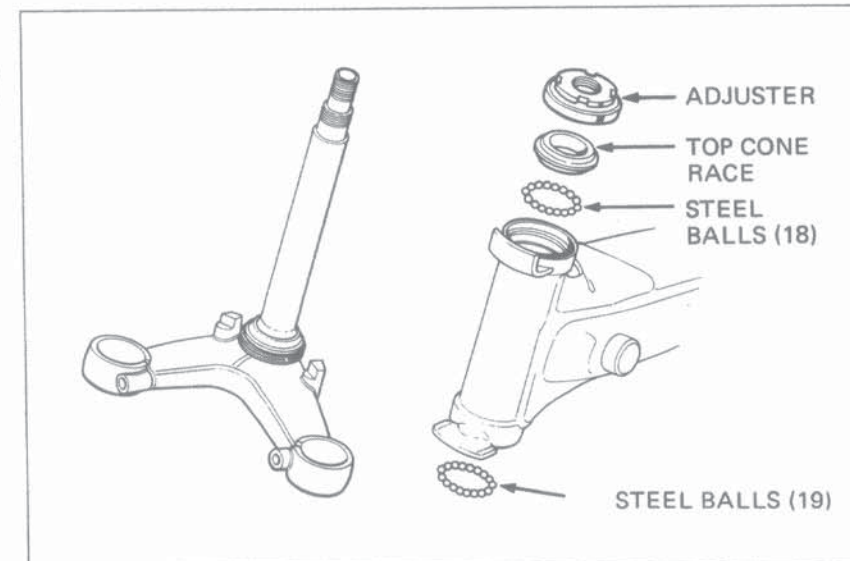



**FRONT WHEEL/SUSPENSION**

Install the adjuster in the frame neck and tighten it until snug against the top cone race. Then, back it out 1/8 turn. Make sure that there is no vertical movement and the stem rotates freely.

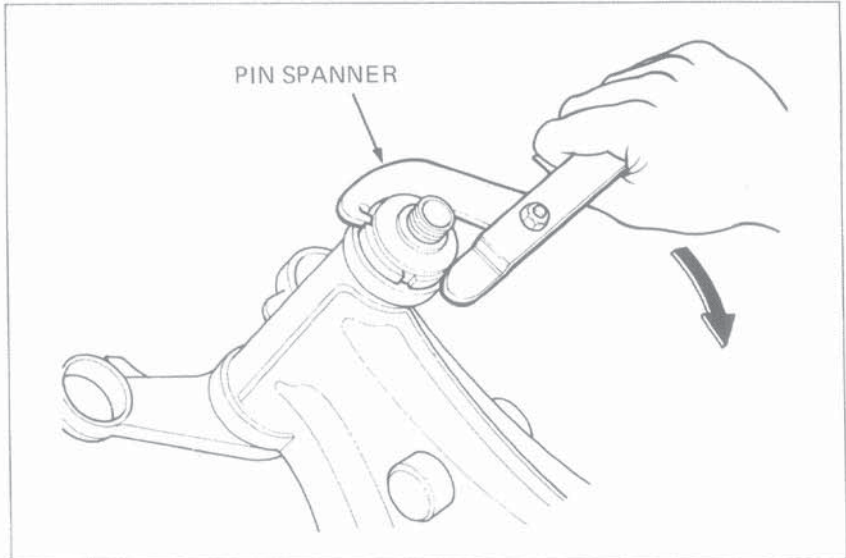

Install the front fork legs.

**NOTE**

Do not interchange the right and left fork legs.

Temporarily hold the fork tubes by tightening the steering stem bolts.

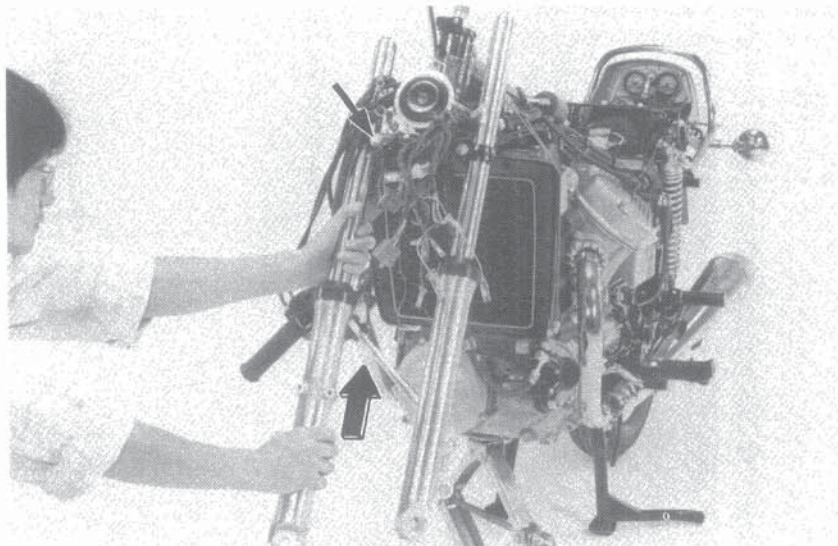

Install the fork top bridge. Insert each fork into the front fork top bridge. Torque the steering stem nut.

**TORQUE SPECIFICATION:**  
9.0–12.0 kg-m (65–87 ft-lbs)

Torque the stem fixing bolt.  
**TORQUE SPECIFICATION:**  
1.8–2.5 kg-m (13–18 ft-lbs)

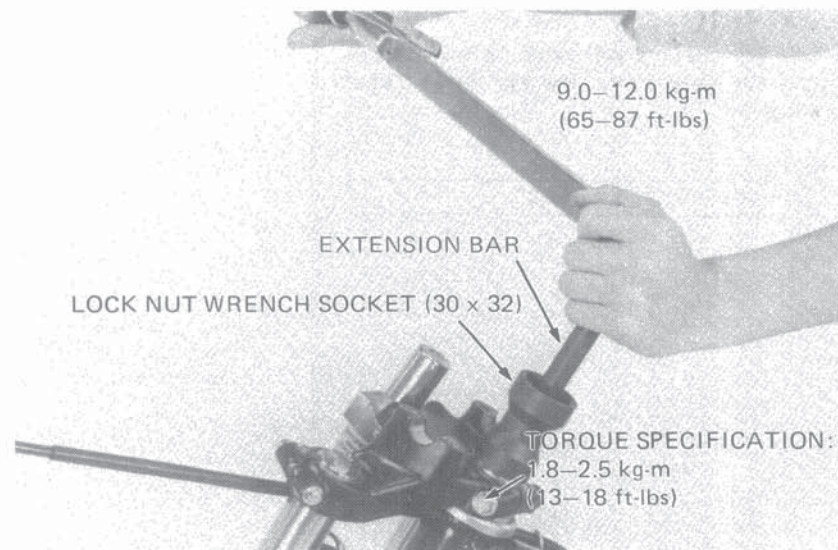





Align the tube's top edge flush with the top of the fork bridge.

Tighten the steering stem bolts.

**TORQUE SPECIFICATION:**

1.8–2.5 kg-m (13–18 ft-lbs)

Tighten the fork bridge bolts.

**TORQUE SPECIFICATION:**

0.9–1.3 kg-m (7–9 ft-lbs)

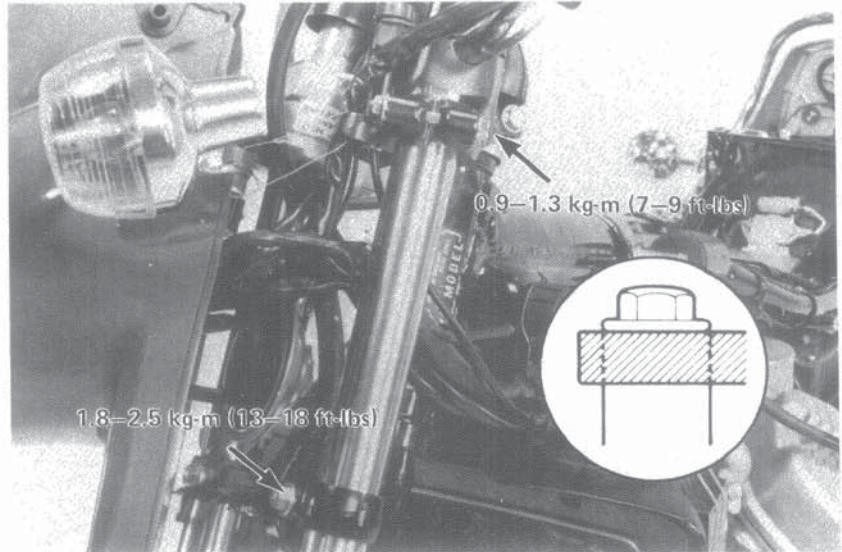

Install the following:

- HANDLEBAR (Page 13–4)
- HEADLIGHT CASE (Page 13–2)
- FRONT FENDER
- FRONT WHEEL (Page 13–8)

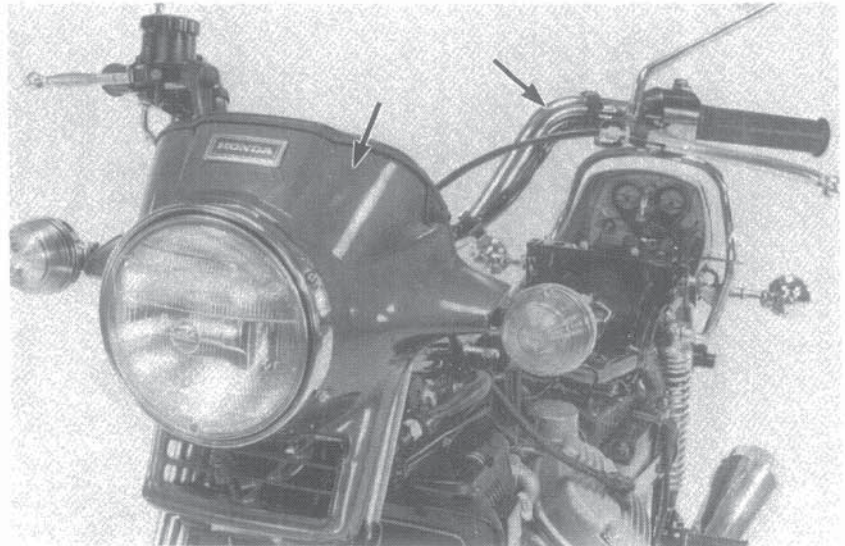

REAR WHEEL/BRAKE/  
FINAL DRIVE/SUSPENSION



**HONDA**  
**CX500**

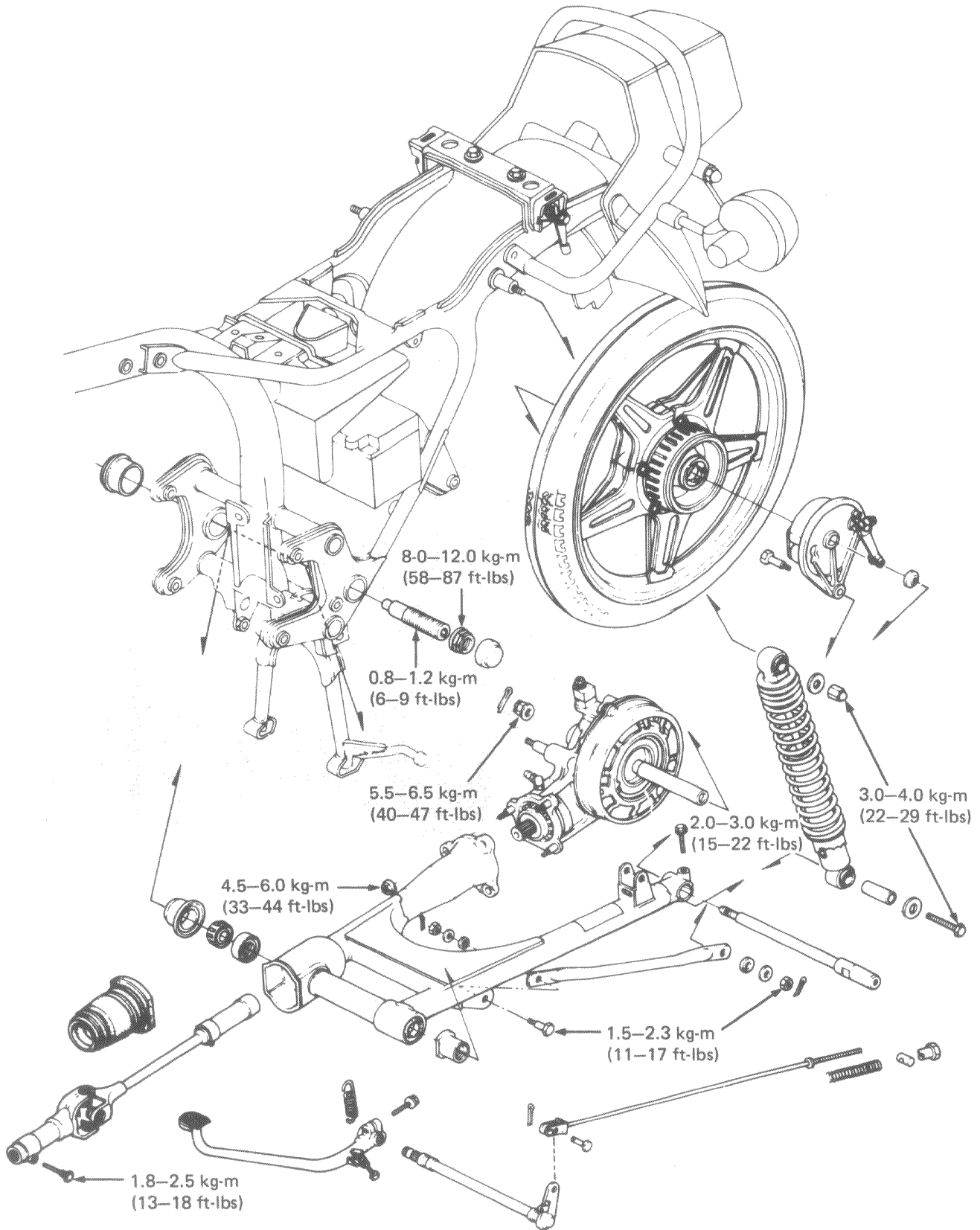





SERVICE INFORMATION	14-1
TROUBLESHOOTING	14-2
REAR WHEEL REMOVAL/ DISASSEMBLY/ASSEMBLY	14-3
REAR BRAKE PANEL	14-7
REAR WHEEL INSTALLATION	14-8
SHOCK ABSORBER	14-9
FINAL DRIVE	14-12
REAR FORK/PROPELLER SHAFT	14-23

## SERVICE INFORMATION

### • WORKING PRACTICE

Do not remove the rivets, nuts and pins from the rim, spoke plates and hub, since they cannot be disassembled.

Do not ride on the rim or try to bend the wheel.

Avoid damaging the aluminum alloy rim.

Check that the tire and rim are free from damage as the tire is tubeless.

When removing the tire from the rim, use the special tools "TIRE LEVER" and "RIM PROTECTOR" to prevent damage to the rim.

For tubeless tire repairs, see the "HONDA MOTORCYCLE TUBELESS TIRE REPAIR MANUAL".

### • SPECIAL TOOLS

#### Special tools

TIRE LEVER	07772-0020100
RIM PROTECTOR	07772-0020200
FINAL RETAINER WRENCH	07910-3710000
RETAINER B WRENCH	07910-4150000
SOCKET BIT (10 mm)	07917-3710000
SLIDING WEIGHT	07936-3710200
PIVOT BEARING OUTER REMOVER	07936-4150000
MECHANICAL SEAL DRIVER ATTACHMENT	07945-4150200
RING GEAR DIS/ASSEMBLY TOOL SET	07965-4150000
CENTER SHAFT DIS/ASSEMBLY TOOL	07965-4150100
DIS/ASSEMBLY TOOL A	07965-4150200
DIS/ASSEMBLY TOOL B	07965-3710200
DIS/ASSEMBLY TOOL C	07965-3710300
PRELOAD INSPECTION TOOL	07998-4150000

#### Common tools

RETAINER WRENCH B	07710-0010200
RETAINER WRENCH BODY	07710-0010401
LOCK NUT WRENCH SOCKET (30 x 32 mm)	07716-0020400
EXTENSION BAR HANDLE	07716-0020500
PIN DRIVER (3.5 mm)	07744-0010300
BEARING DRIVER OUTER (42 x 47 mm)	07746-0010300
BEARING DRIVER OUTER (52 x 55 mm)	07746-0010400
BEARING DRIVER PILOT (15 mm)	07746-0040300
BEARING DRIVER PILOT (30 mm)	07746-0040700
BEARING DRIVER HANDLE (A)	07749-0010000
REAR SHOCK ABSORBER COMPRESSOR	07959-3290001

### • SPECIFICATIONS

		STANDARD		SERVICE LIMIT	
Axle bend		—		0.2 mm	(0.008 in.)
Rear wheel runout	Radial	—		2.0 mm	(0.08 in.)
	Axial	—		2.00 mm	(0.08 in.)
Brake lining thickness		4.9 – 5.0 mm	(0.19 – 0.20 in.)	2.0 mm	(0.08 in.)
Rear brake drum I.D.		160.0 mm	(8.06 in.)	161.0 mm	(6.34 in.)
Shock absorber spring free length		249.3 mm	(8.07 in.)	245.5 mm	(8.05 in.)
Final gear backlash		0.08 – 0.18 mm	(0.0032 – 0.0071 in.)	0.25 mm	(0.0098 in.)



## TROUBLESHOOTING

### Wobble or Vibration

1. Distorted rim
2. Loose wheel bearing
3. Loose or distorted spokes
4. Faulty tire
5. Loose axle

### Soft Suspension

1. Weak spring
2. Shock absorbers improperly adjusted
3. Weak rear damper

### Hard Suspension

1. Shock absorbers improperly adjusted

### Suspension Noise

1. Shock case binding
2. Loose fasteners

### Poor Brake Performance

1. Improper brake adjustment
2. Fouled brake linings
3. Worn brake shoes
4. Worn brake shoe cam contacting faces
5. Worn brake drum
6. Improper engagement between brake arm and shaft serrations

### Final drive gear noise

1. Oil level too low
2. Excessive backlash
3. Drive shaft splines damaged or worn
4. Insufficient lubricant





## REAR WHEEL REMOVAL/ DISASSEMBLY/ASSEMBLY

### • REAR WHEEL REMOVAL

Place the motorcycle on its center stand.  
Remove the cotter pin and loosen the axle nut.

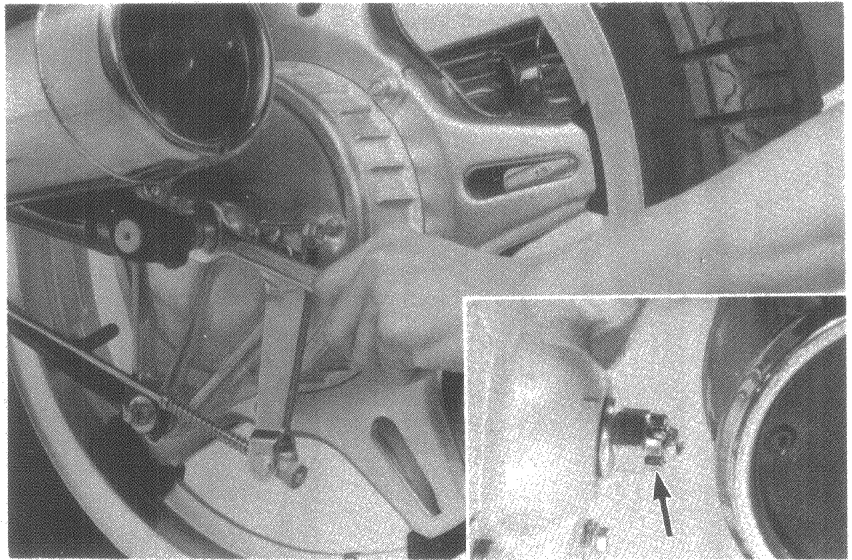

Loosen the axle holder bolt.  
Remove the cotter pin and remove the brake  
torque link.  
Remove the brake adjusting nut and the brake  
rod.

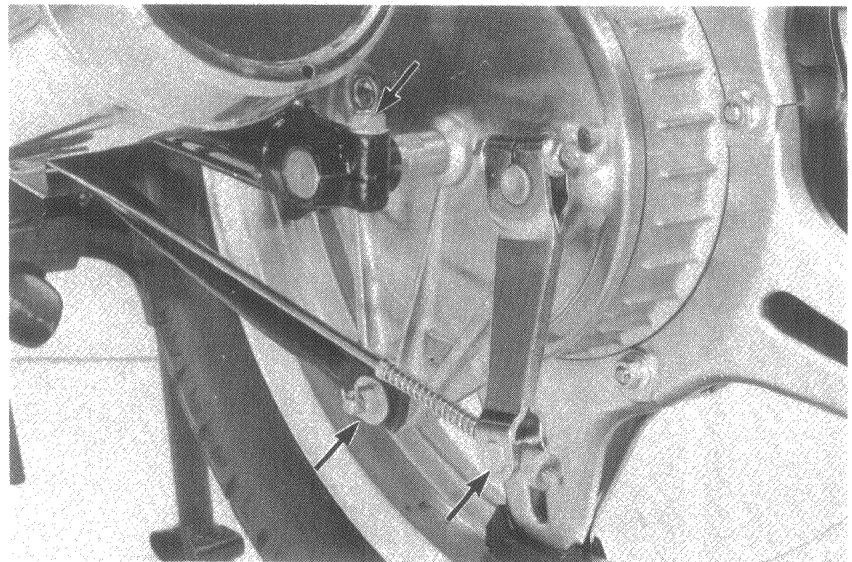

Remove the rear axle.

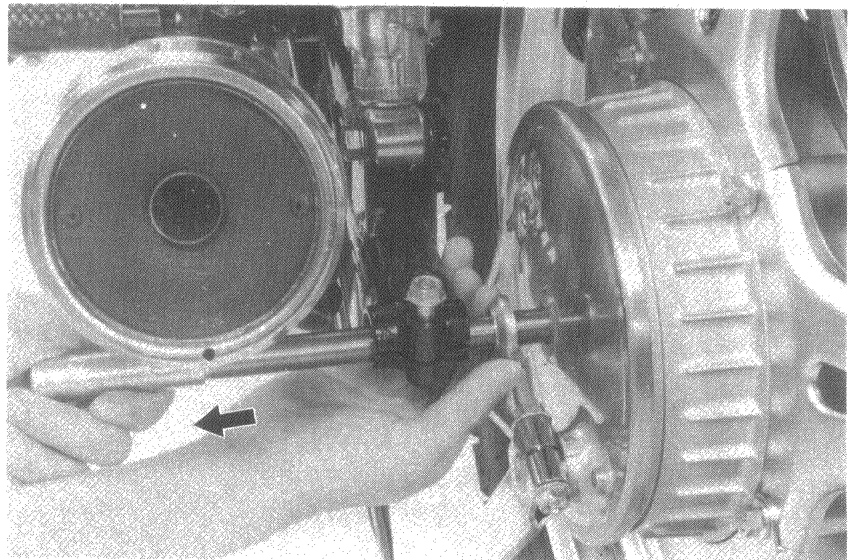



Push the rear wheel toward the left away from the final drive gear and then remove the wheel with the brake panel by pulling it backward.

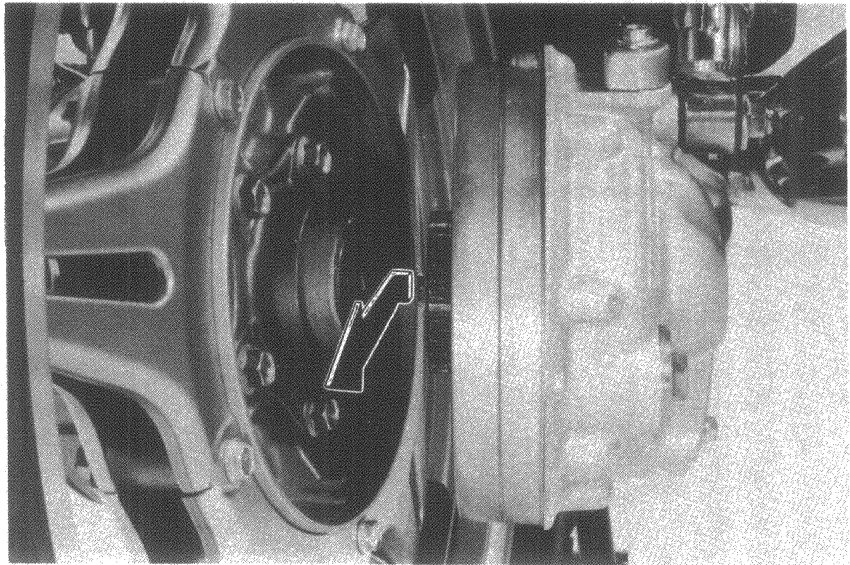

• **AXLE SHAFT BEND INSPECTION**

Set the axle shaft in V-blocks and measure the axle shaft runout. The actual axle bend is 1/2 of TIR (Total Indicator Reading).

SERVICE LIMIT: 0.2 mm (0.008 in.)

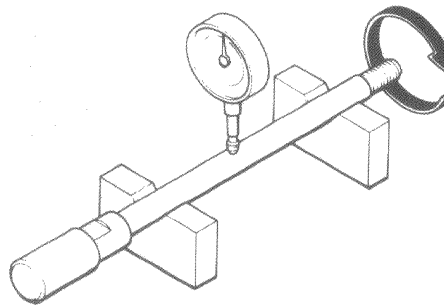

• **REAR WHEEL BEARING PLAY INSPECTION**

Rotate the rear wheel by hand.  
Replace the wheel bearings with new ones if they are noisy or have excessive play.

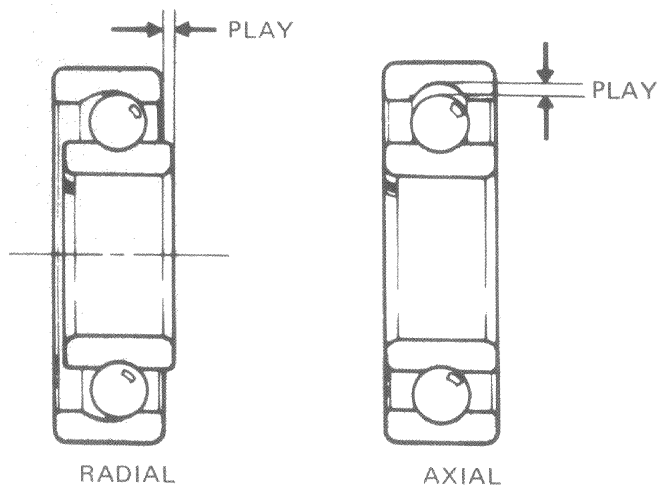





### ● REAR WHEEL RIM RUNOUT INSPECTION

Check the rim for runout by placing the wheel in a truing stand. Spin the wheel by hand, and read the runout using a dial indicator gauge.

#### NOTE

The COMSTAR WHEEL cannot be serviced and must be replaced if the above limits are exceeded.

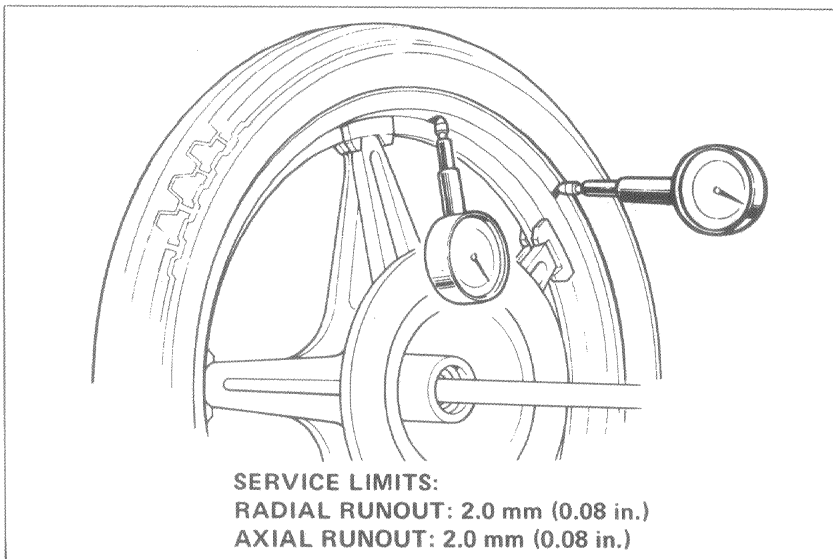

### ● REAR WHEEL DISASSEMBLY

Remove the bearing retainer.

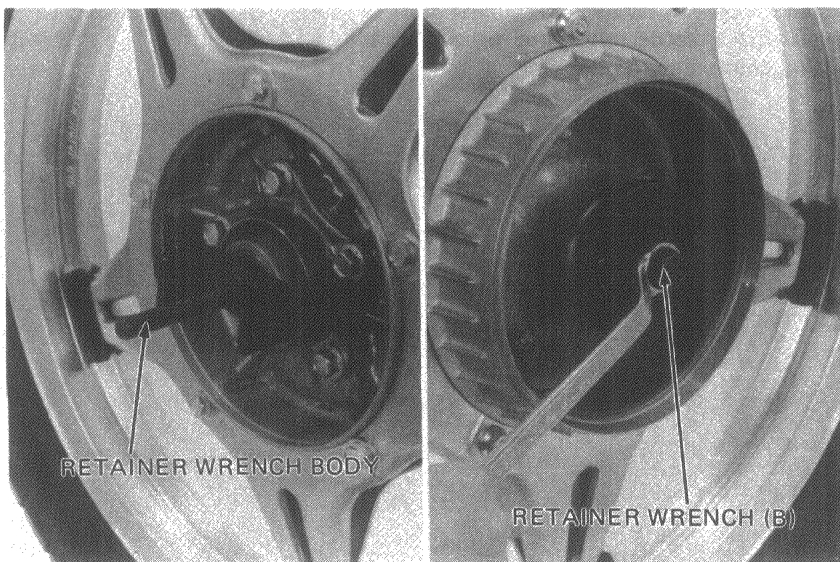

#### NOTE

Tubeless tires are standard.

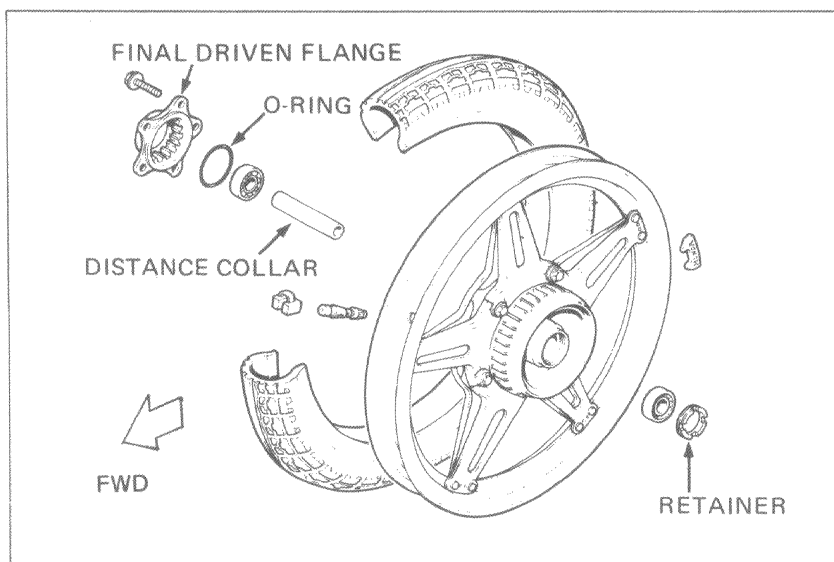



• REAR WHEEL ASSEMBLY

Pack all bearing cavities with grease and drive in the bearing with a bearing driver.  
Drive the left (retainer side) bearing first.

NOTE

Drive the bearings squarely.

BEARING DRIVER HANDLE (A)  
BEARING DRIVER OUTER (42 x 47 mm)  
BEARING DRIVER PILOT (17 mm)

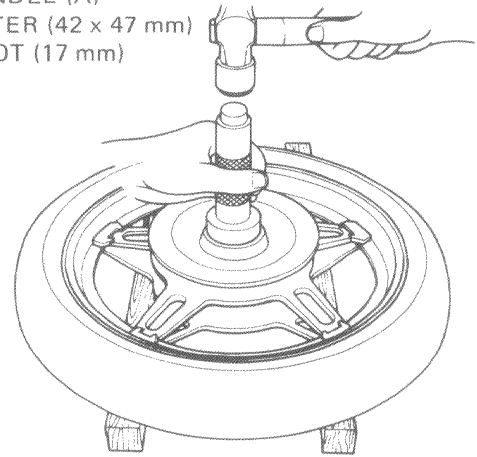

Install the bearing retainer and punch it.  
Install the distance collar and drive the right bearing into place.

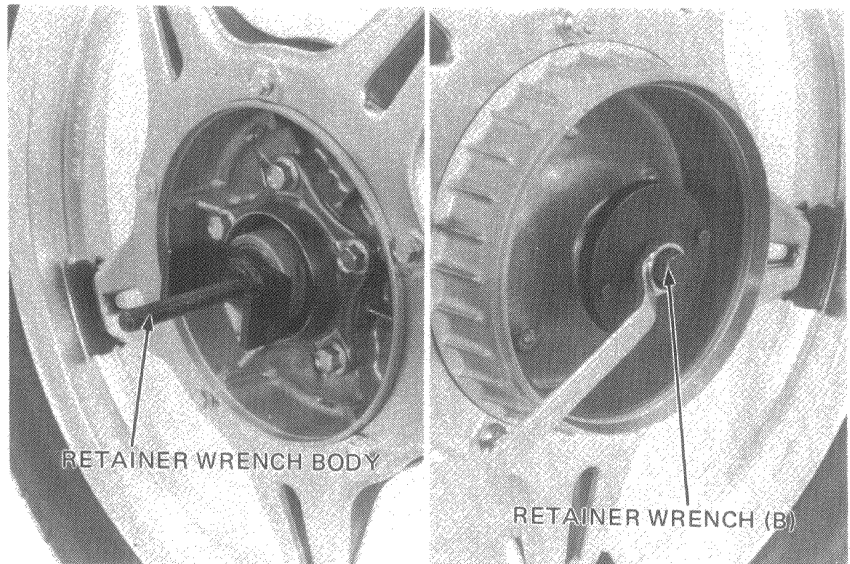

Install the O-ring and lubricate the splines and O-ring with lithium-based multipurpose grease.  
Install the final driven flange.

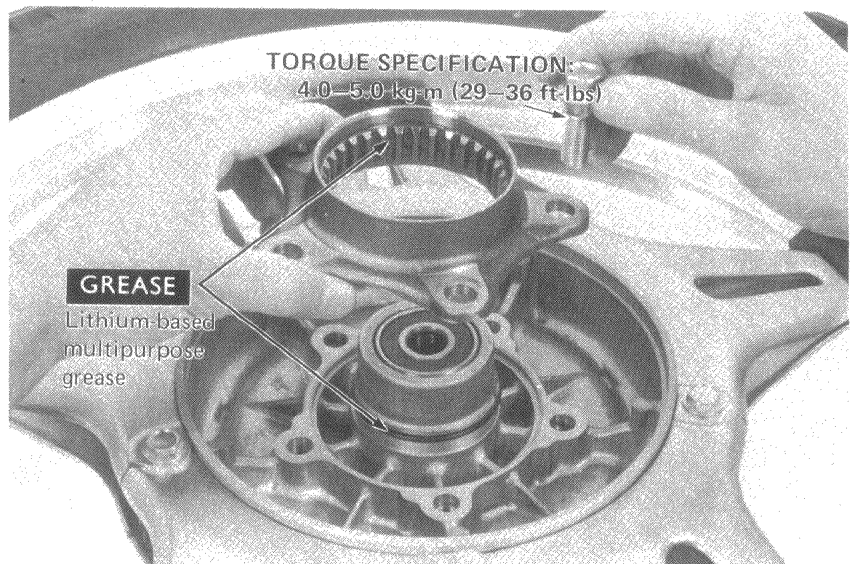





### REAR BRAKE PANEL

- REAR BRAKE LINING THICKNESS

Measure the rear brake lining thickness.

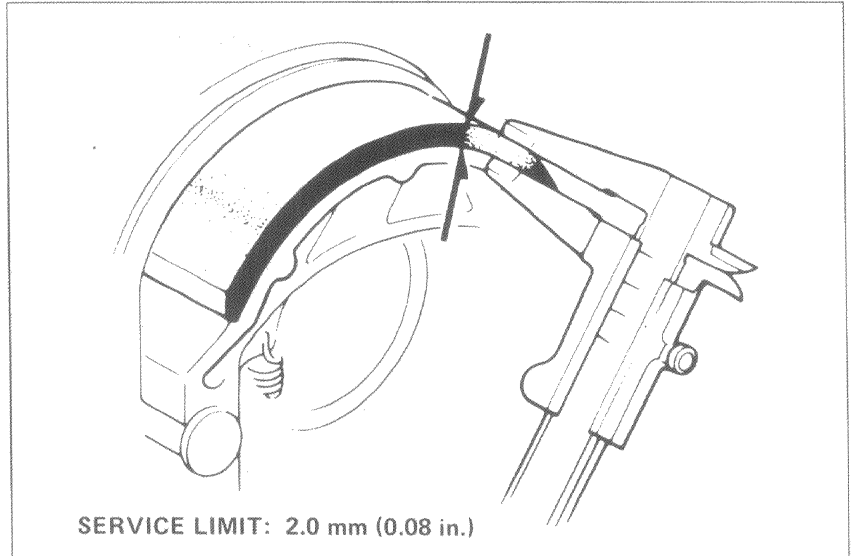

- REAR BRAKE SHOE REPLACEMENT

Remove the cotter pins.  
Install new brake shoes.  
Apply grease to the face of the brake cam.

**WARNING**

*Contaminated brake linings reduce stopping power.  
Keep grease off the brake linings. Wipe the excess grease off the cam.*

**NOTE**

Make sure the punch mark on the brake arm aligns with the punch mark on the brake camshaft.

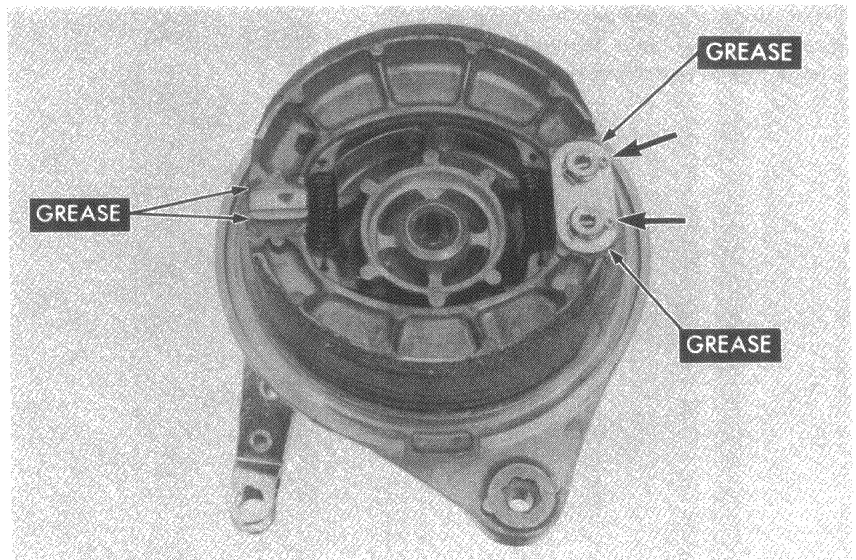

- BRAKE DRUM I.D. INSPECTION

Measure the brake drum I.D..

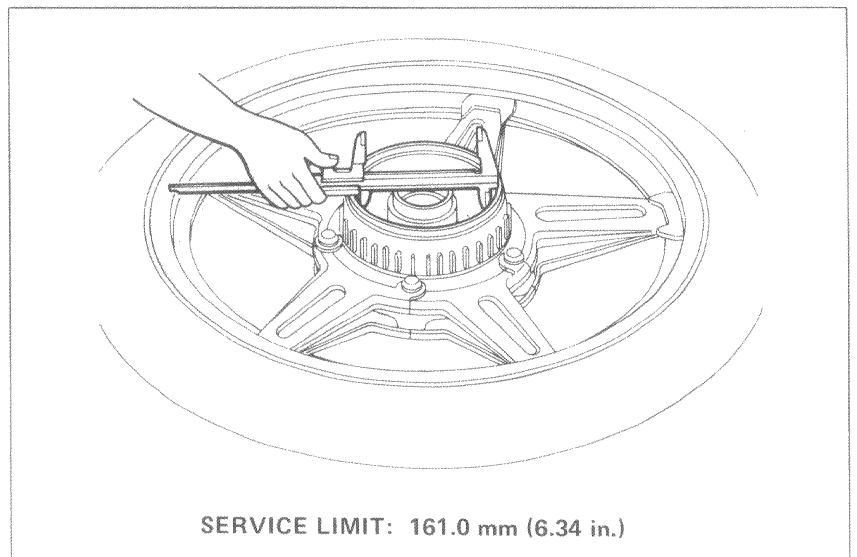



## REAR WHEEL INSTALLATION

Apply lithium-based multipurpose grease to the final driven flange spline of the rear wheel and ring gear.

Insert the distance collar into the final gear case in the direction shown.

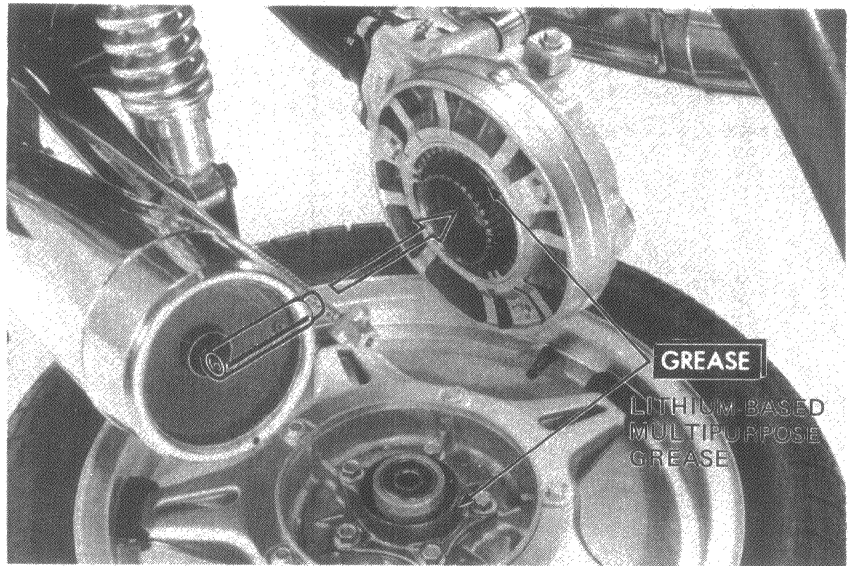

Install the rear wheel and brake panel.  
Insert the rear axle through the swing arm, washer, brake panel and rear wheel.

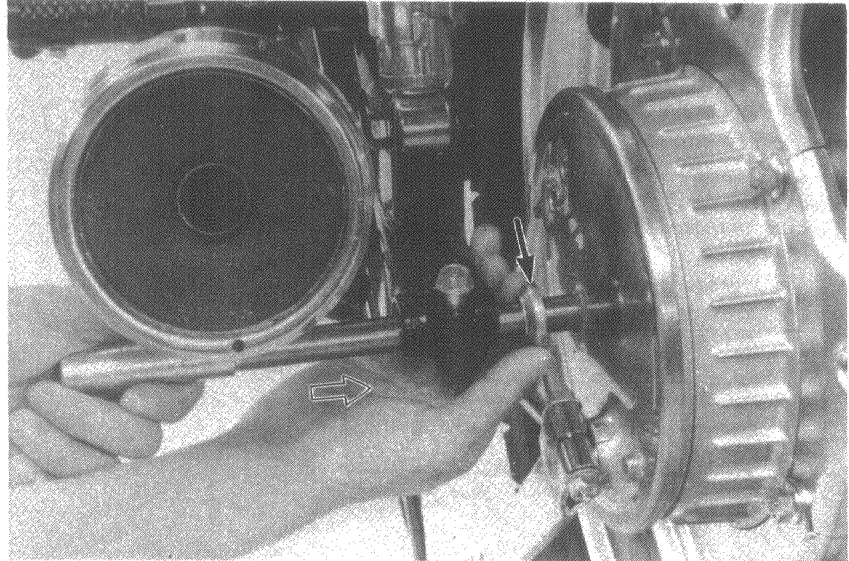

Connect the brake rod.

Install the brake torque link.

**TORQUE SPECIFICATION:**

1.5–2.3 kg-m (11–17 ft-lbs)

Torque the axle nut.

**TORQUE SPECIFICATION:**

3.4 – 4.0 kg-m (22– 29 ft-lbs)

Tighten the axle fixing bolt.

**TORQUE SPECIFICATION:**

2.0–3.0 kg-m (15–22 ft-lbs)

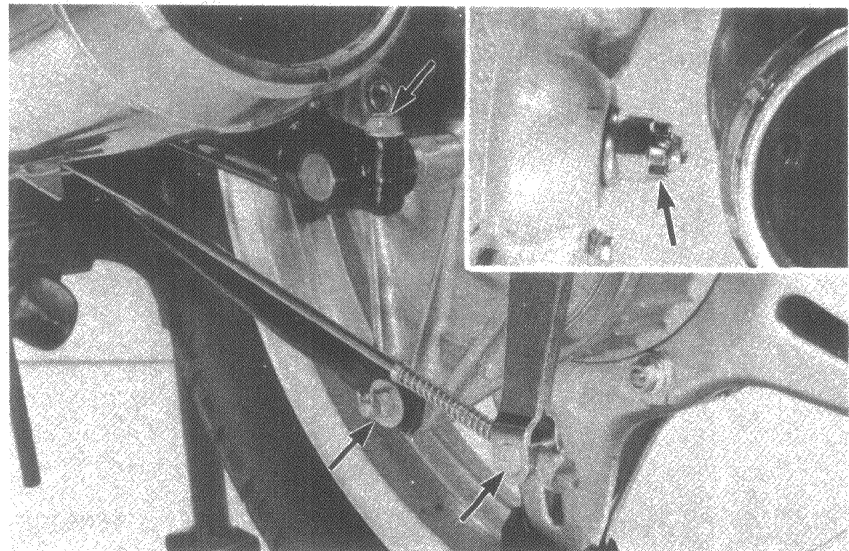





## SHOCK ABSORBER

- SHOCK ABSORBER (RIGHT SIDE) REMOVAL

### NOTE

Before removing the rear shock absorber, rotate the adjuster to the softest position.

Remove the upper and lower attaching nuts.  
Remove the shock absorber.

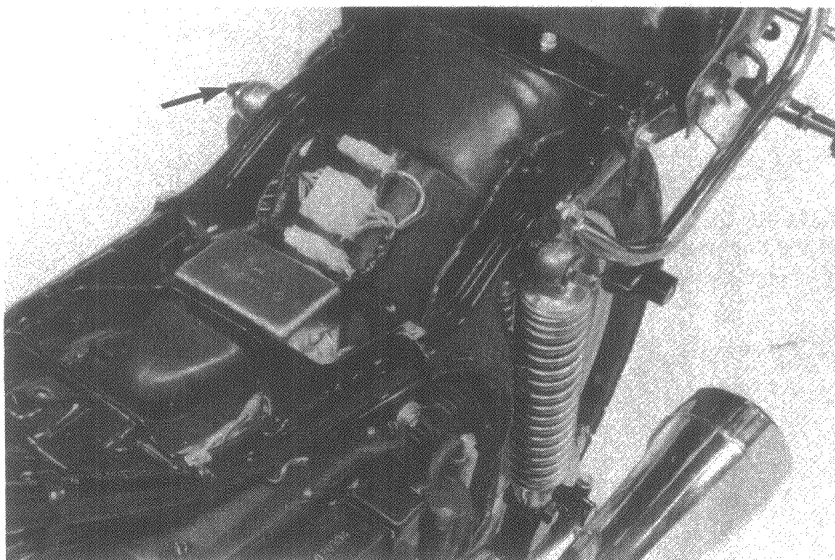

- SHOCK ABSORBER (LEFT SIDE) REMOVAL

Remove the upper attaching nuts and the upper parts of both rear shock absorbers from the holders.

Loosen the left side lower bolt and pull out the bolt while lifting the rear wheel.

Remove the shock absorber.

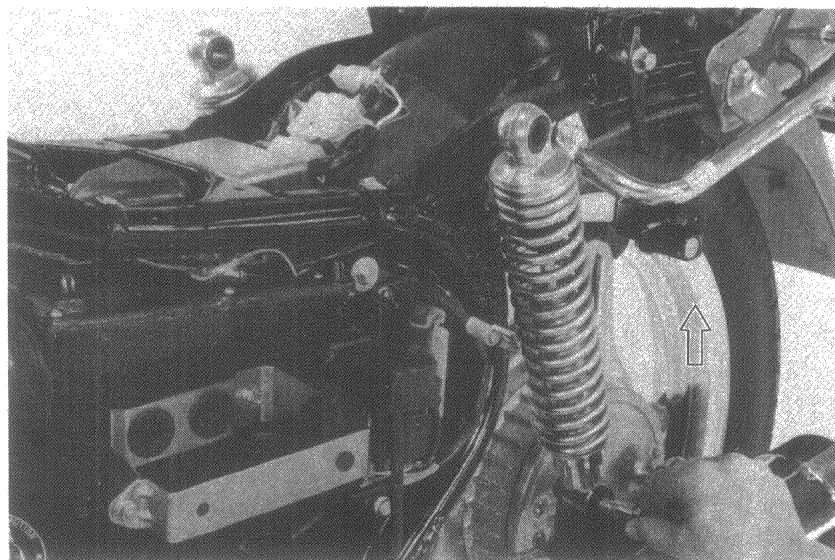

- SHOCK ABSORBER DISASSEMBLY NOTE

Make sure that the shock absorber is in the softest position.

Set the rear cushion in the compressor as shown and compress the spring 30 mm by turning the compressor handle.

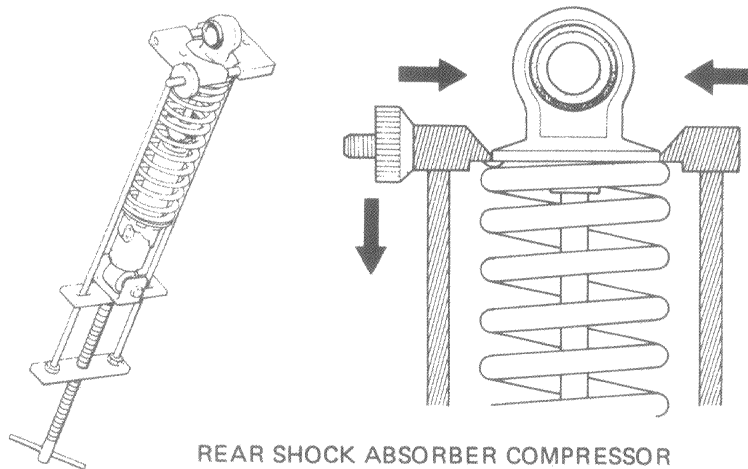

REAR SHOCK ABSORBER COMPRESSOR



Place the upper joint in a vise and pull out the rod.

**NOTE**

Loosen the holder nut to aid removal of the damper.

Separate the upper joint rotating the lock nut in the direction shown.  
Remove the compressor.

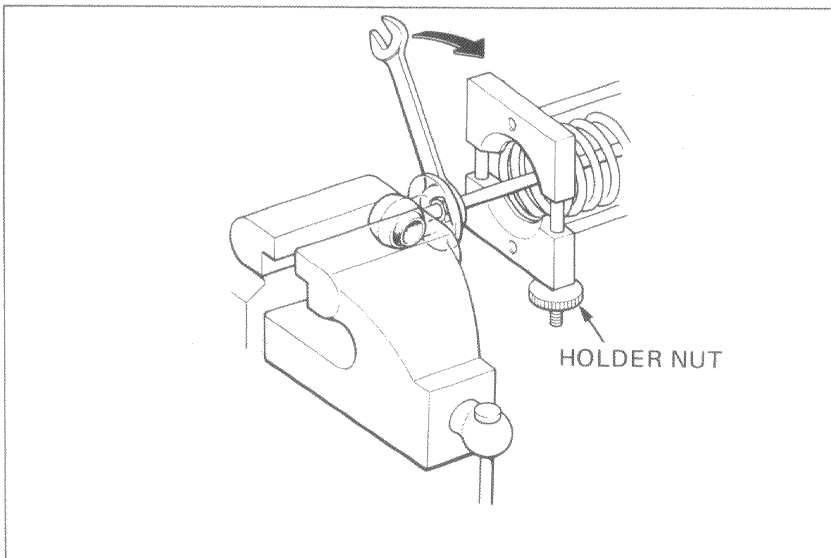

• **SHOCK ABSORBER SPRING FREE LENGTH**

Measure the rear shock absorber spring free length.

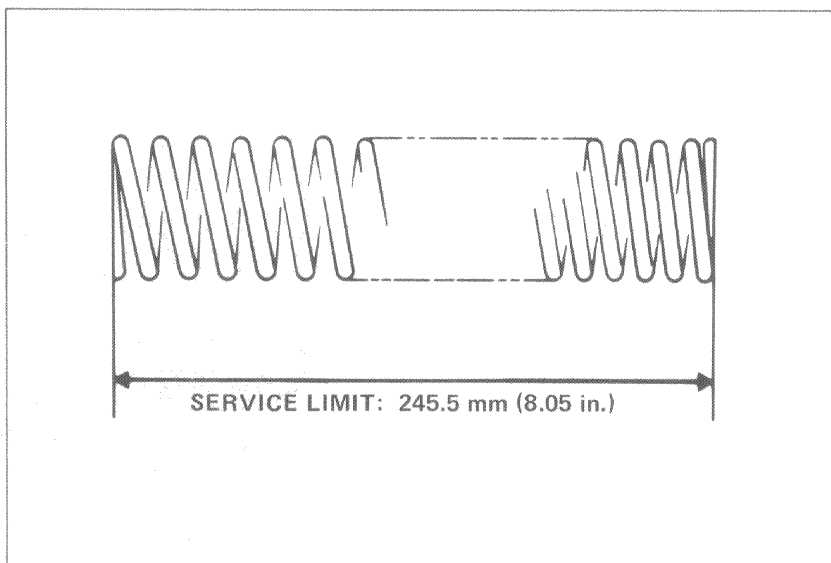

• **SHOCK ABSORBER ASSEMBLY**

Install the spring adjuster, the spring under seat, spring and stopper rubber on the damper.

**NOTE**

Install the spring with the tightly wound end facing up.

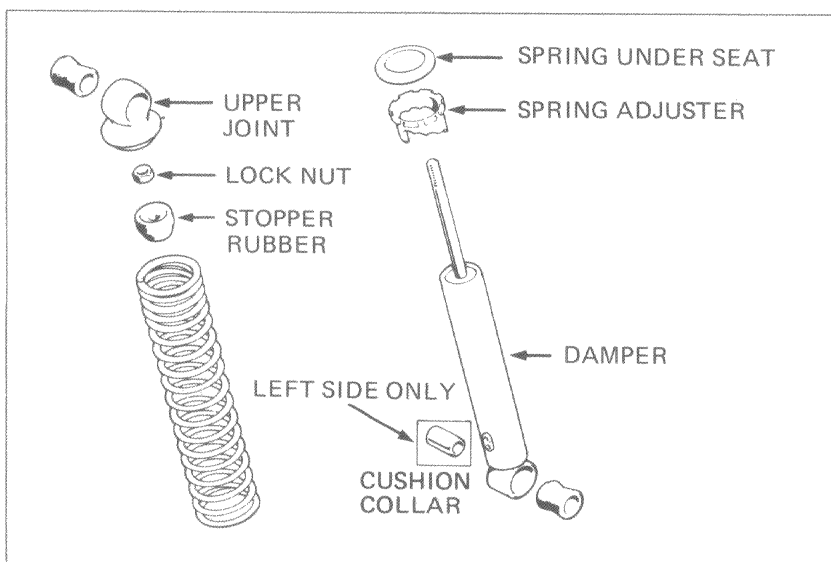





Apply locking agent to the rod threads and tighten the lock nut securely.  
Attach the shock absorber compressor.

**WARNING**

*Screw in the holder nut to prevent the spring from coming out of position.*

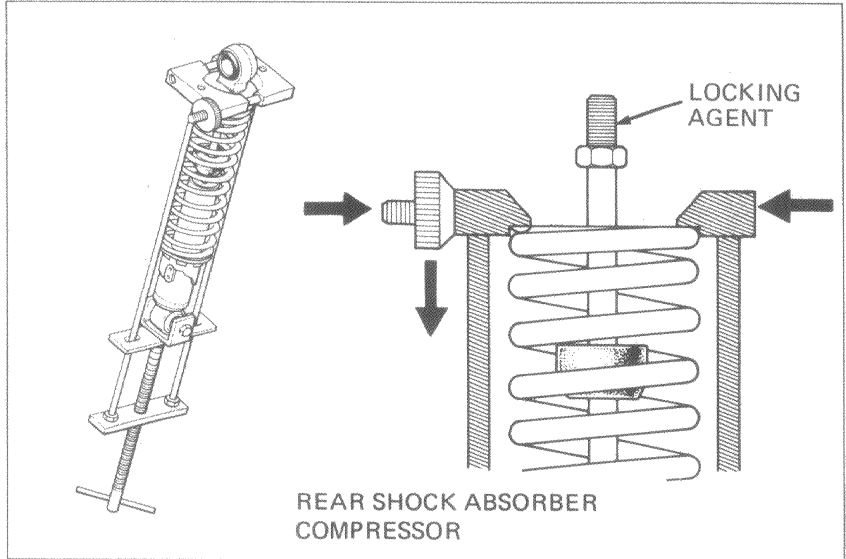

Apply locking agent to the rod threads.  
Place the upper joint in a vise and tighten the rock nut securely.

**NOTE**

Check that the locknut is seated against the rod's bottom thread.

Align the spring with the upper joint by loosening the holder nuts while releasing the compressor.

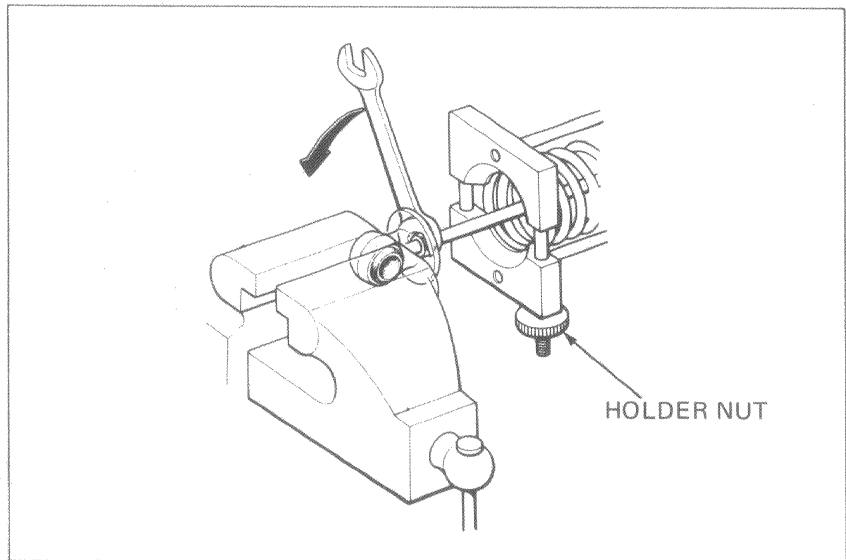
**• SHOCK ABSORBER  
INSTALLATION**

Lift the rear wheel and install the left absorber lower bolt, with the right absorber removed.

**TORQUE SPECIFICATION:**  
3.0 – 4.0 kg-m (22 – 29 ft-lbs)

Position the right and left shock absorber adjusters equally.

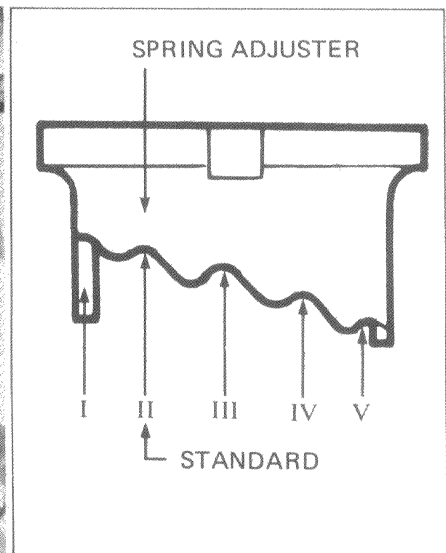
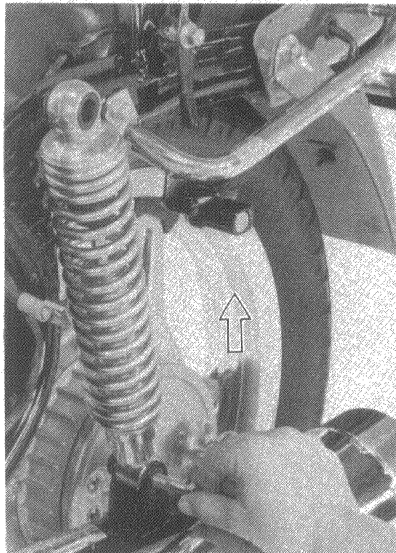



## FINAL DRIVE

### • FINAL GEAR CASE REMOVAL

Place the motorcycle on its center stand.  
Remove the rear wheel. (Page 14-3)  
Remove the distance collar.  
Remove the final gear case attaching nuts.  
Remove the final gear case from the swing arm and remove the drive hub from the shock absorber.

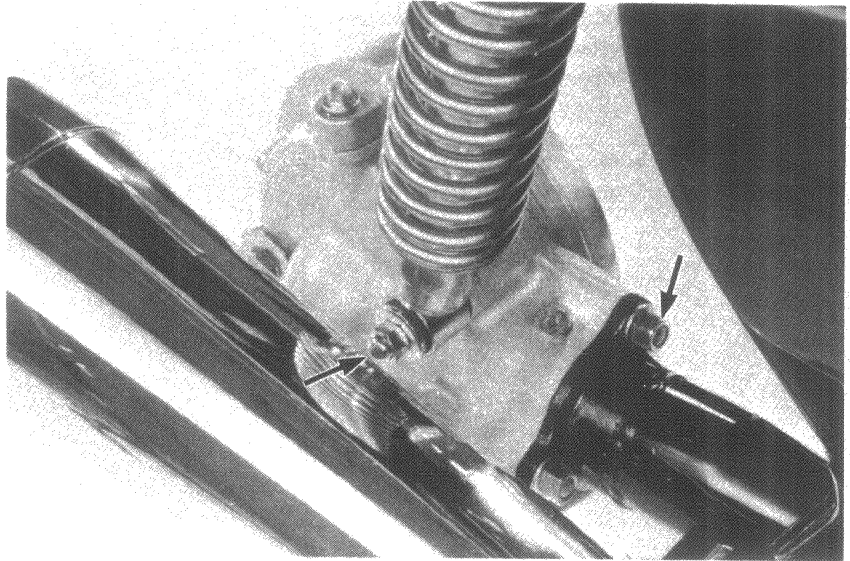

### • BACKLASH INSPECTION

Place the final gear case in a vise.

#### NOTE

Do not tighten the drive hub in the vise excessively.

Set up a dial indicator on the ring gear teeth. Install the preload inspection tool (P/N 07998-4150000) to hold the pinion gear securely. Hold the pinion gear spline securely, rotate the ring gear until gear slack is taken up. Turn the ring gear back and forth to read backlash.

Measure 3-5 splines.

**SERVICE LIMIT: 0.25 mm (0.0098 in)**

#### NOTE

Ring gear control spacers are available in increments of 0.040 mm. Each change in spacer thickness will decrease or increase backlash 0.015 mm.

If the backlash is too great use a thinner spacer.  
If the backlash is too little use a thicker spacer.

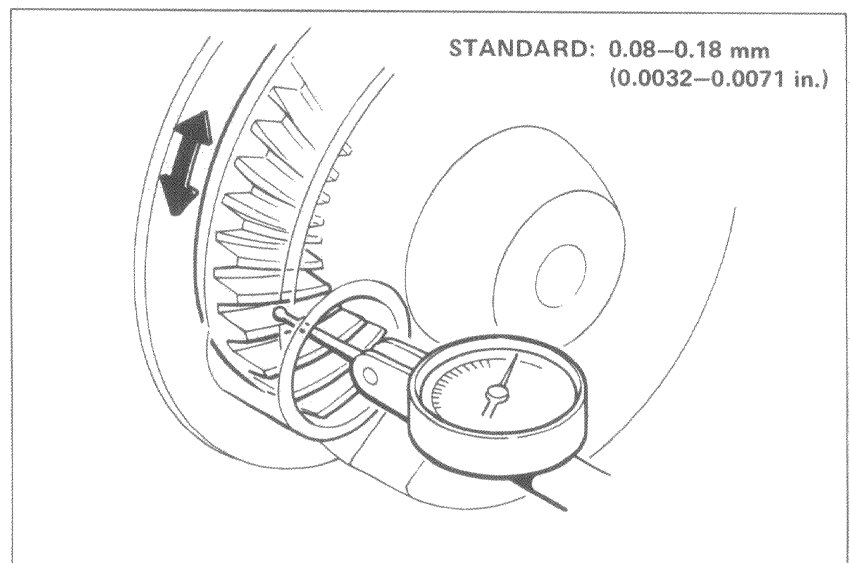
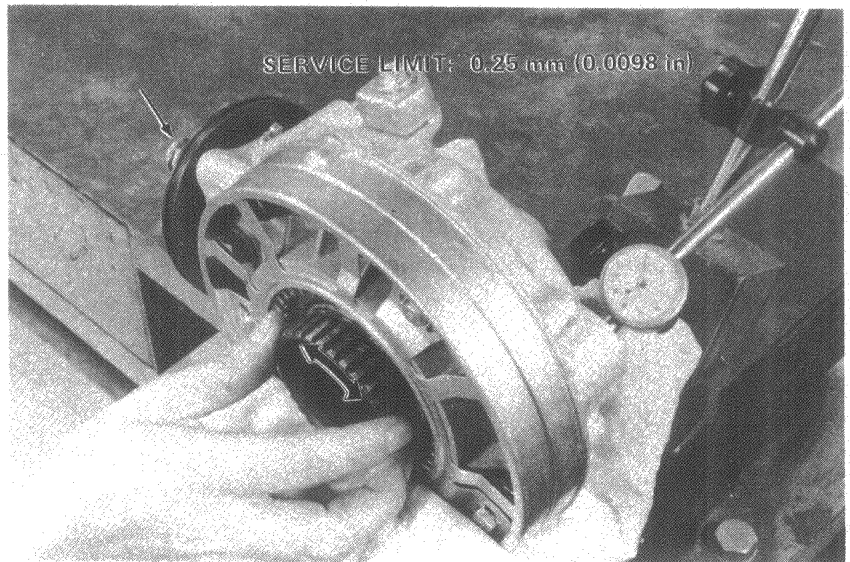





• **RING GEAR REMOVAL**

Straighten the tabs of the lock plates and remove the dust guard plate.

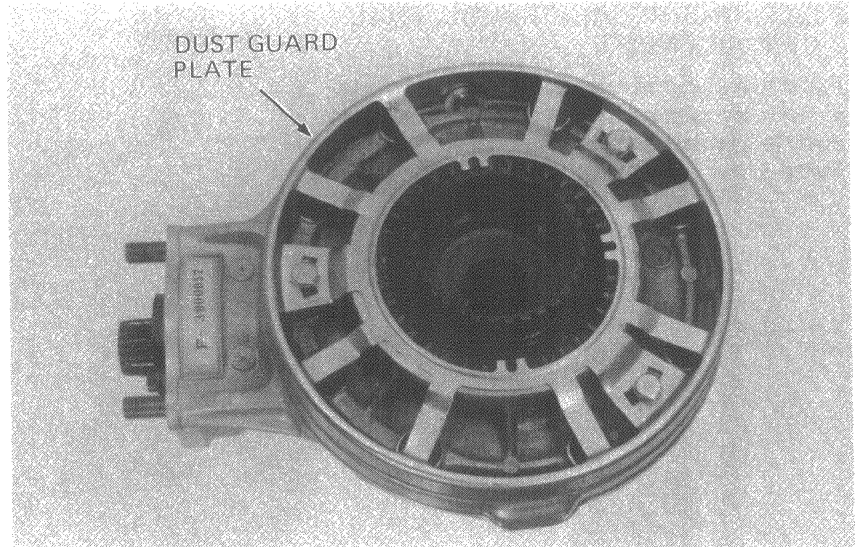

Remove bearing retainer A with the O-ring and oil seal.

Remove the eight left gear case cover bolts and left gear case cover with the ring gear and bearing.

Remove the ring gear spacer from the case.

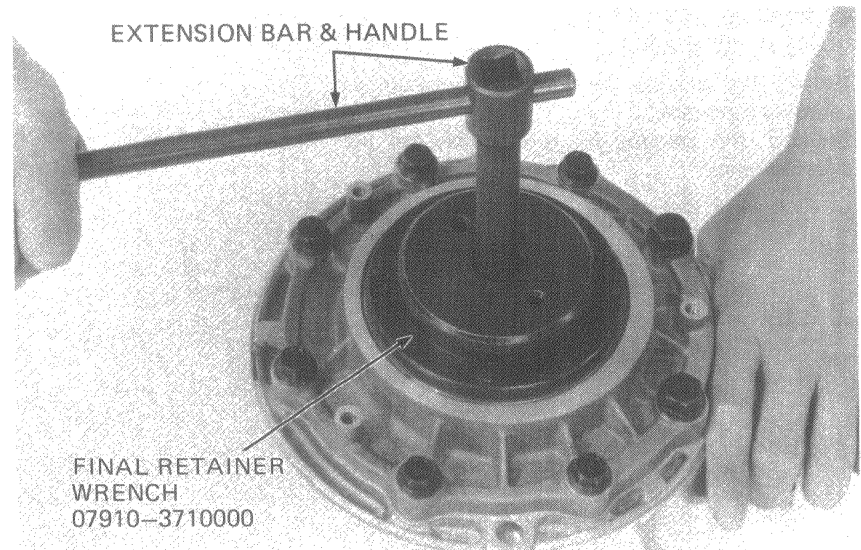

Separate the left case cover from the ring gear and bearing.

**NOTE**

When separating the left case cover from the ring gear and bearing, tap it lightly with a soft hammer. Avoid damaging the cover and bearing.

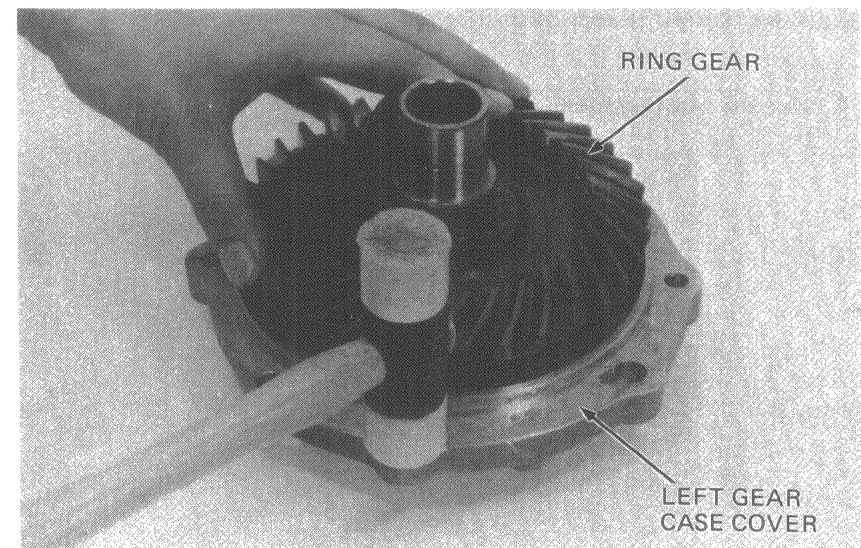



• BEARING RETAINER A OIL SEAL  
REPLACEMENT

Inspect the bearing retainer A oil seal. If the lip is worn or damaged, or if the spring band is distorted, replace the oil seal.  
Install a new O-ring.

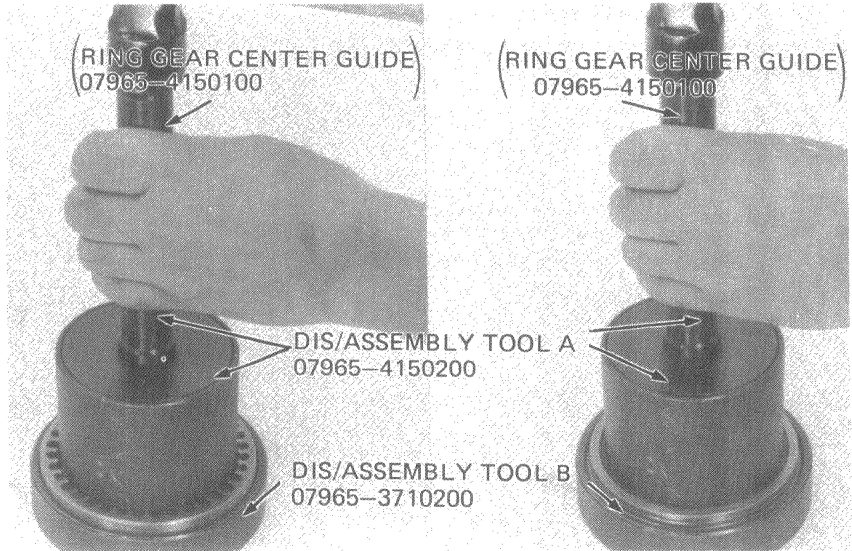

• RING GEAR BEARING  
REPLACEMENT

Inspect the bearing for smooth operation by spinning it by hand.  
Replace the bearing if it is noisy or has excessive play.

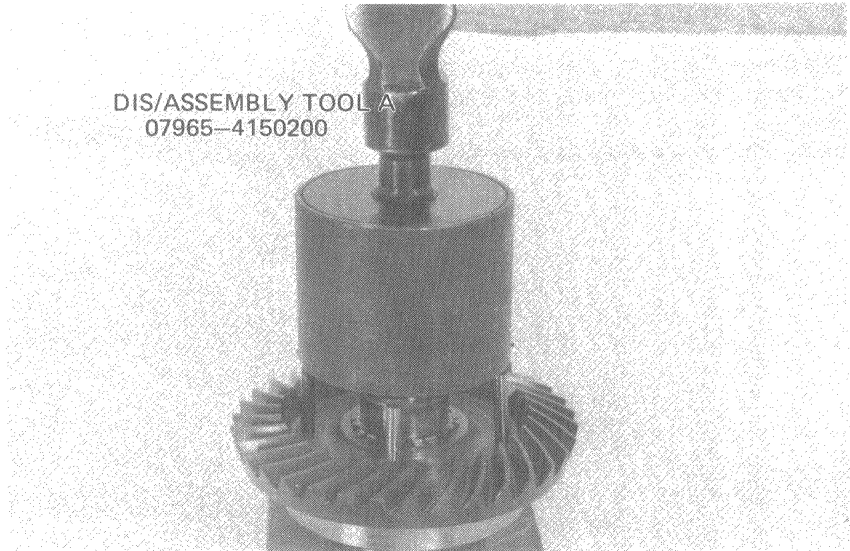

Install the ring gear bearing on the ring gear.

NOTE

Drive the bearing in until it seats properly.

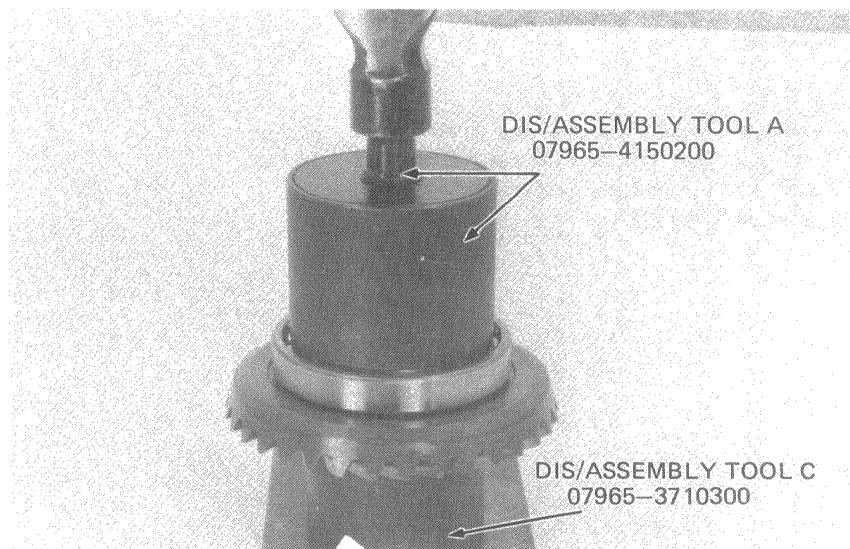





### • BREATHER SYSTEM MAINTENANCE

Check the breather hole for clogging. Clean if necessary.

#### NOTE

Clean around and inside of the breather cap.

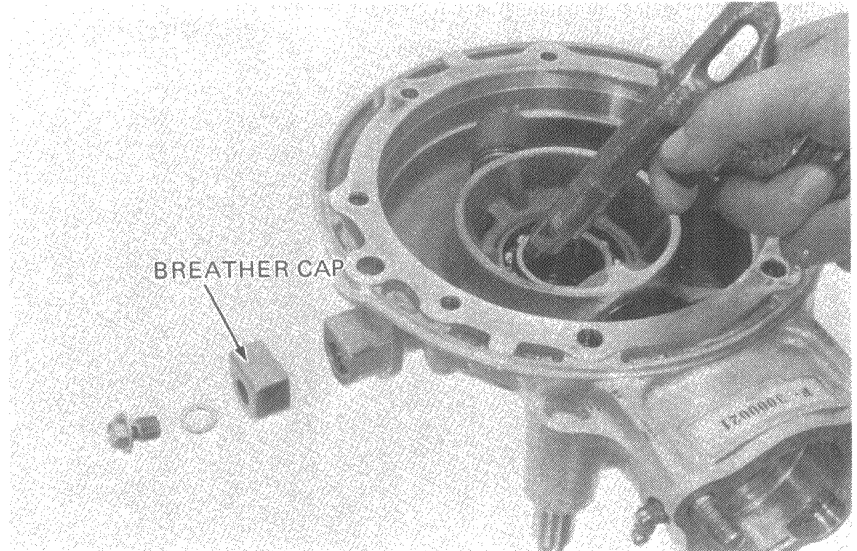

### • RING GEAR OIL SEAL REPLACEMENT (GEAR CASE SIDE)

Inspect the ring gear oil seal for leakage. Replace the oil seal if the lip is damaged or if the spring band is distorted. If replacement is necessary, it is necessary to remove the ring gear bearing.

#### NOTE

Drive the oil seal in squarely.

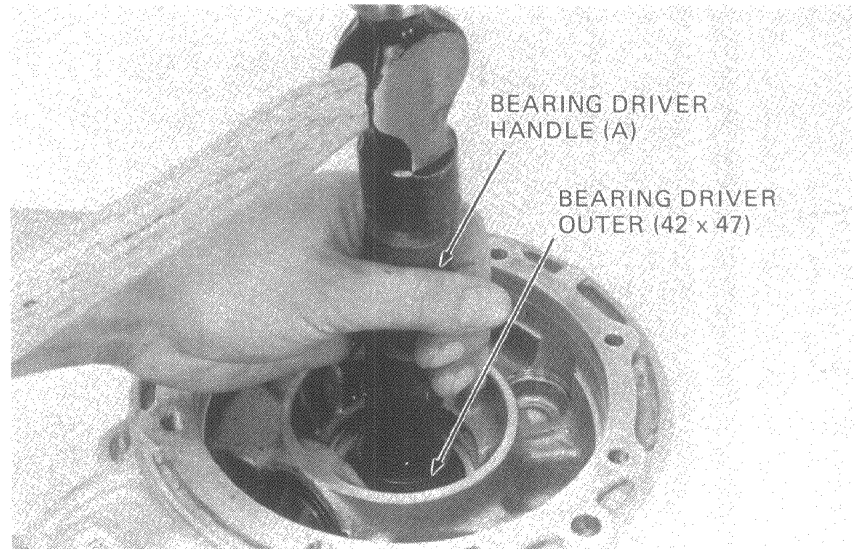

### • RING GEAR BEARING REPLACEMENT (GEAR CASE SIDE)

Inspect the bearing for smooth operation spinning it by hand. Replace the bearing with a new one if it is noisy or has excessive play.

#### NOTE

Drive the bearing in squarely.

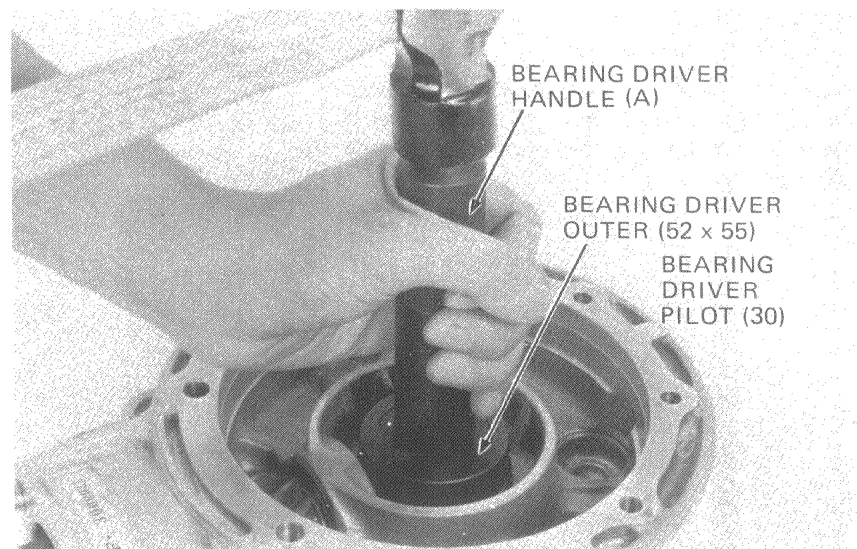



• BEARING RETAINER B REMOVAL

Remove the bearing retainer B lock washer.

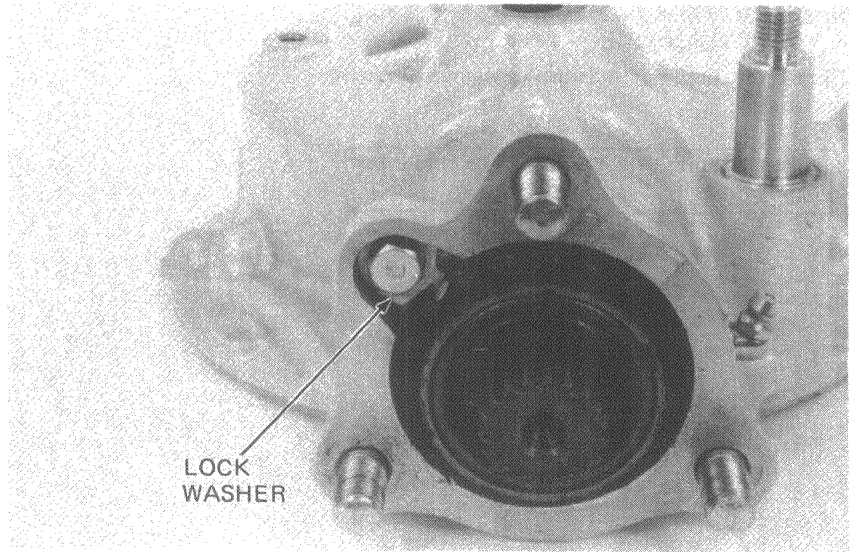

Remove the bearing retainer B.

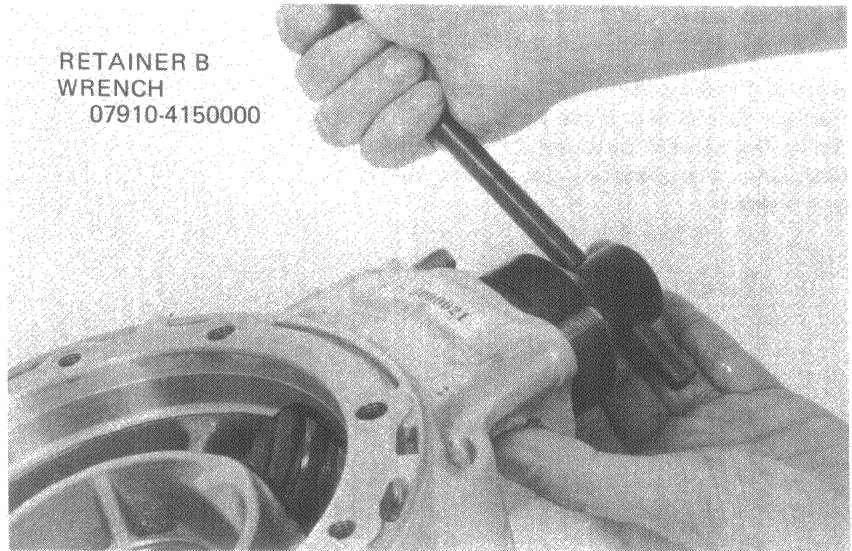

• BEARING RETAINER B OIL SEAL,  
O-RING REPLACEMENT

Inspect the bearing retainer B oil seal. Replace the oil seal if the lip is worn or damaged, or if the spring band is distorted. Replace the O-ring with a new one.

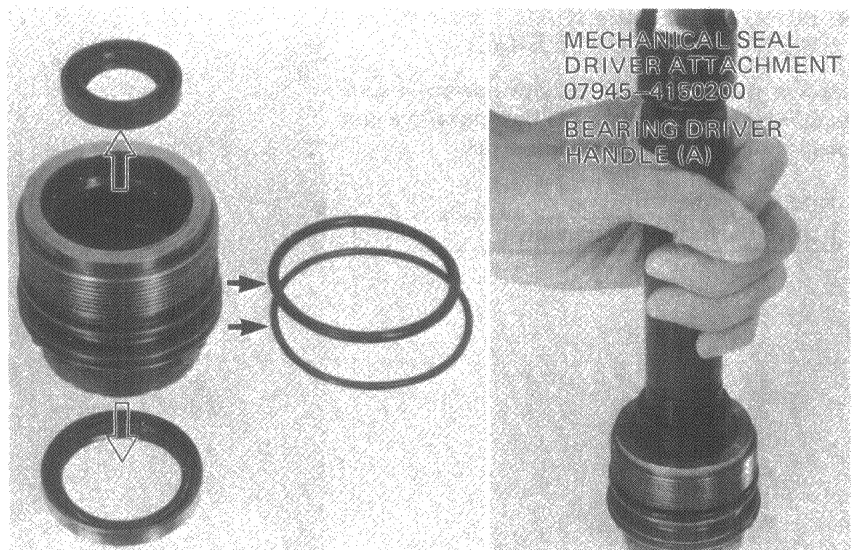





• BEARING RETAINER B  
INSTALLATION

Apply a thin coating of lithium-based multi-purpose grease to the inside of the gear case to prevent damage to the bearing retainer B O-ring during installation.

Lubricate the lip of the oil seal with lithium-based multipurpose grease.

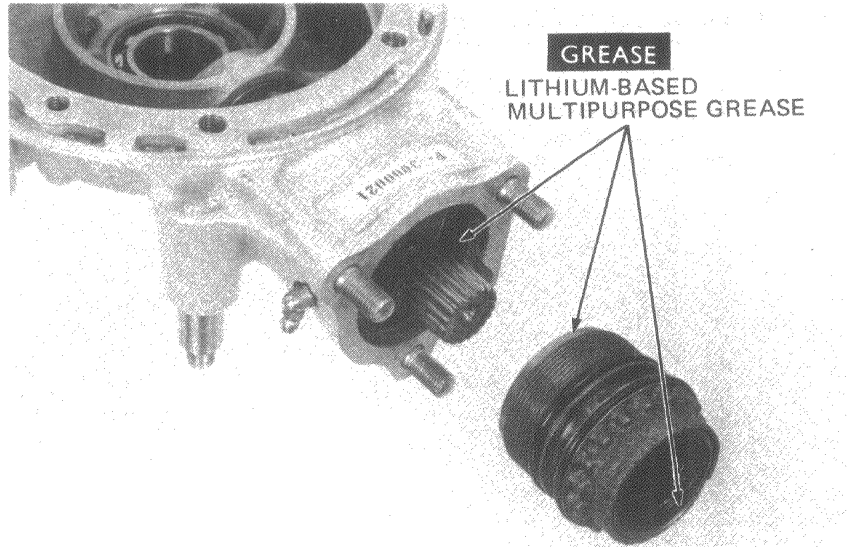

Torque the bearing retainer B.

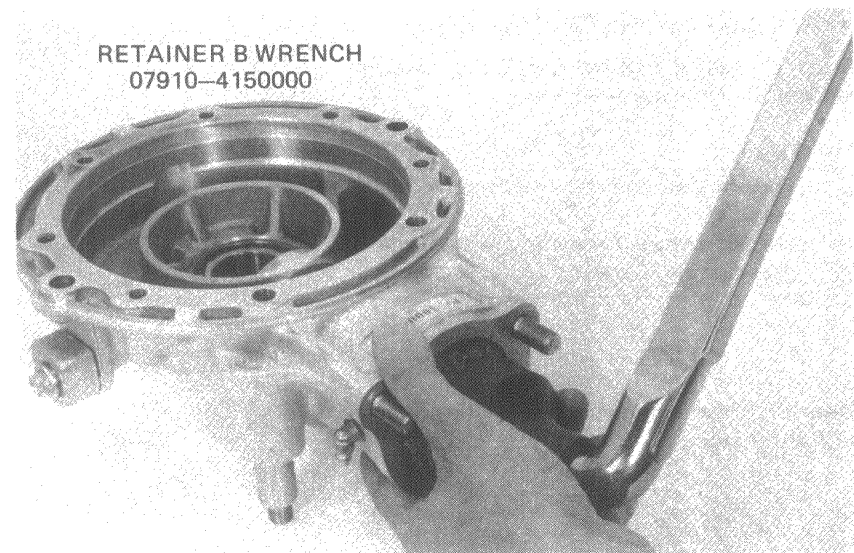

Inspect the pinion preload.

Run a string through a bolt hole in the pinion gear holder and wind it around the outside of the groove.

Attach a spring scale to the string and measure the force needed to turn the holder at one revolution per second.

**NOTE**

Torque required to begin pinion movement may exceed preload limits.

**PINION PRELOAD:** 800–1,000 g  
(1.76–2.2 lbs)

[4.0–5.0 kg-cm (3.48–4.32 in-lbs)]

If the pinion preload is out of specifications, reinstall the bearing retainer B and recheck the preload.

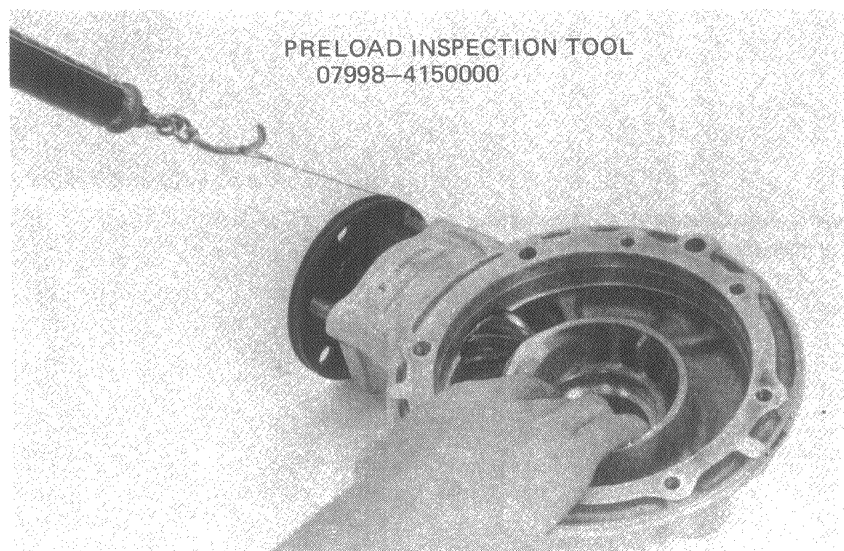



Install the preload retainer B lock tab.

**NOTE**

The lock tabs are available in two types.  
Be sure to use the proper type lock tab.

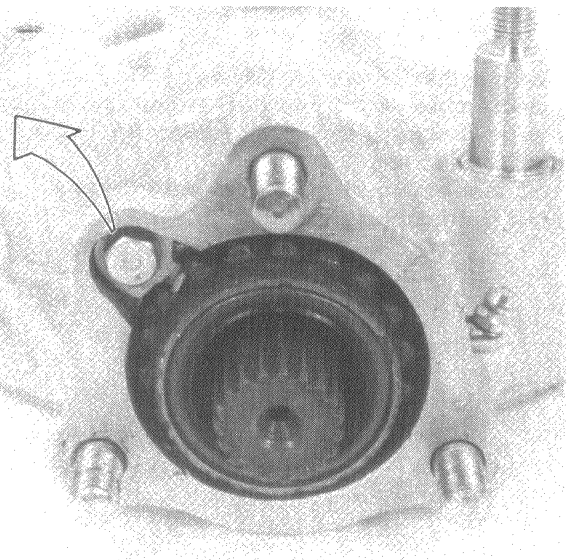
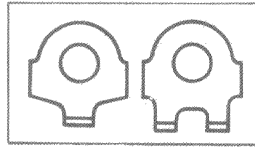

● **RING GEAR INSTALLATION**

Clean all sealing material off the mating surfaces of the gear case and cover.

**NOTE**

- Prevent dust and dirt entering the gear case.
- Do not damage the mating faces of the gear case and cover.

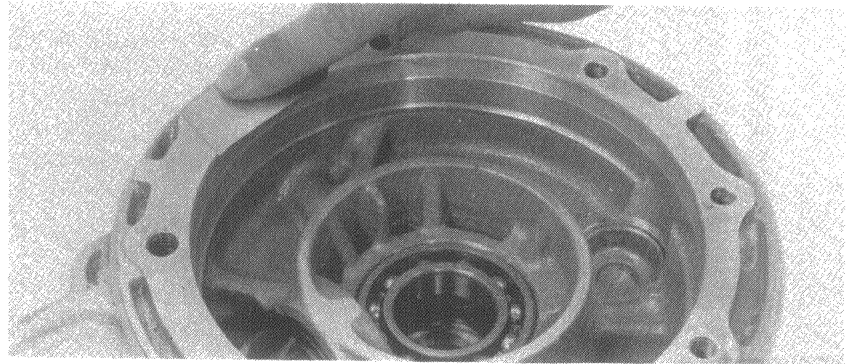

Clean the cover mating surface of the gear case with an oil stone.

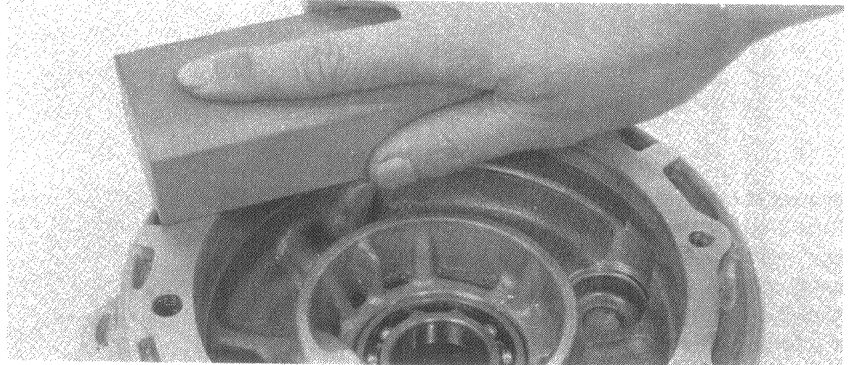

Apply liquid sealant to the mating surfaces of the gear case and cover.

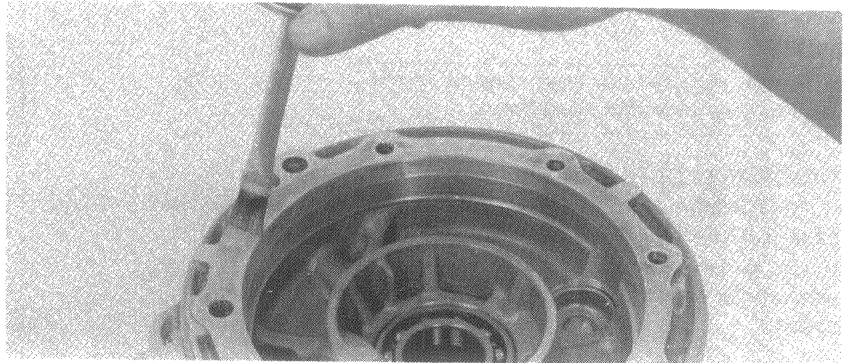





Apply a thin coating of Prussian Blue to the pinion gear teeth for gear tooth contact pattern check, prior to installing the ring gear.  
Assemble the ring gear shim and ring gear in the gear case. Install the left gear case cover.

**NOTE**

Do not allow the left gear case cover to tilt during installing.

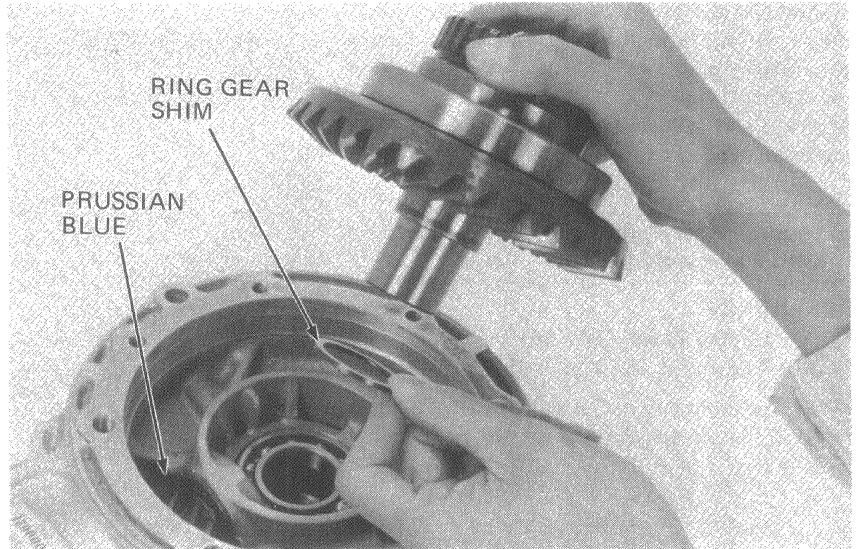

Tighten the three cover bolts showing the sign  $\uparrow$  in 2-3 steps until the left gear case cover touches the gear case. Torque to the specified tension in a cross pattern in two or more steps.

**TORQUE SPECIFICATION:**

- 8 mm bolt: 2.3–2.8 kg-m (17–20 ft-lbs)
- 10 mm bolt: 3.5–4.5 kg-m (25–33 ft-lbs)

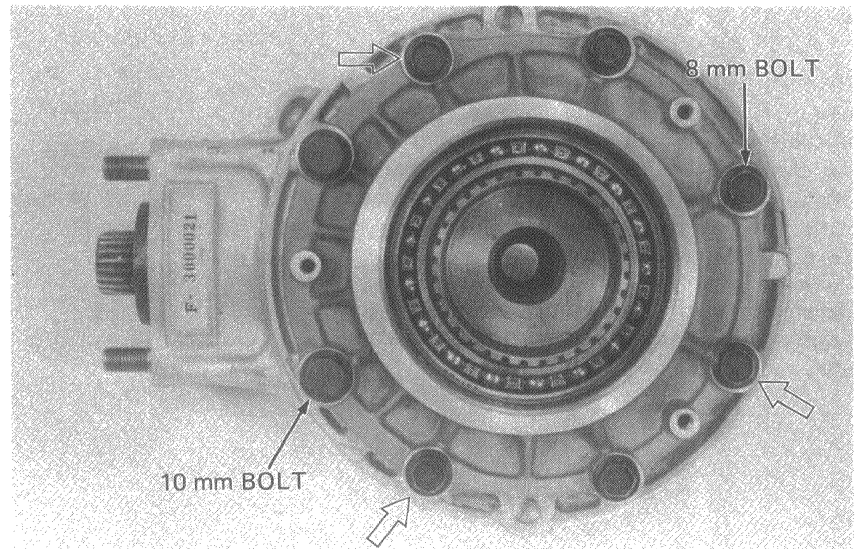

Install the preload retainer A with the oil seal and O-ring assembled in the retainer. Before the retainer bottoms against the bearing, measure the torque T to overcome the friction caused by the O-ring. Tighten the retainer to T + 4.0 kg-m (T + 29 ft-lbs) back-off, and retorque to T + 1.0 kg-m (T + 7 ft-lbs).

**NOTE**

- After assembling the final gear case, perform the following operations:
- Backlash inspection
  - Final gear preload check
  - Final gear tooth contact pattern check

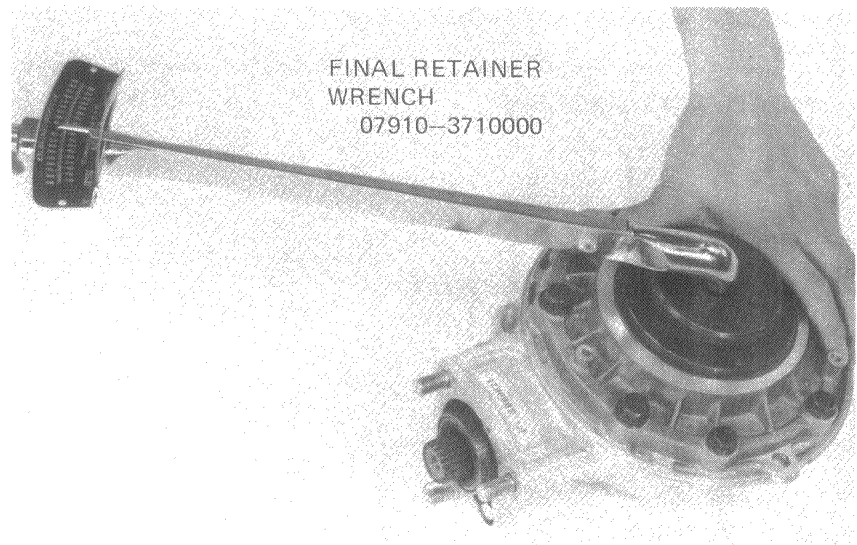



Inspect the assembly preload.

Run a string through a bolt hole in the pinion gear holder and wind it around the outside of the groove.

Attach a spring scale to the string and measure the force needed to turn the holder.

**NOTE**

Torque required to begin pinion movement may exceed preload limits.

**REFERENCE**

1,200–1,800 g (2.65–3.97 lbs)

[6.0–9.0 kg-cm (5.16–7.80 in-lbs)]

If the assembly preload is out of specifications, reinstall the pinion and recheck the preload.

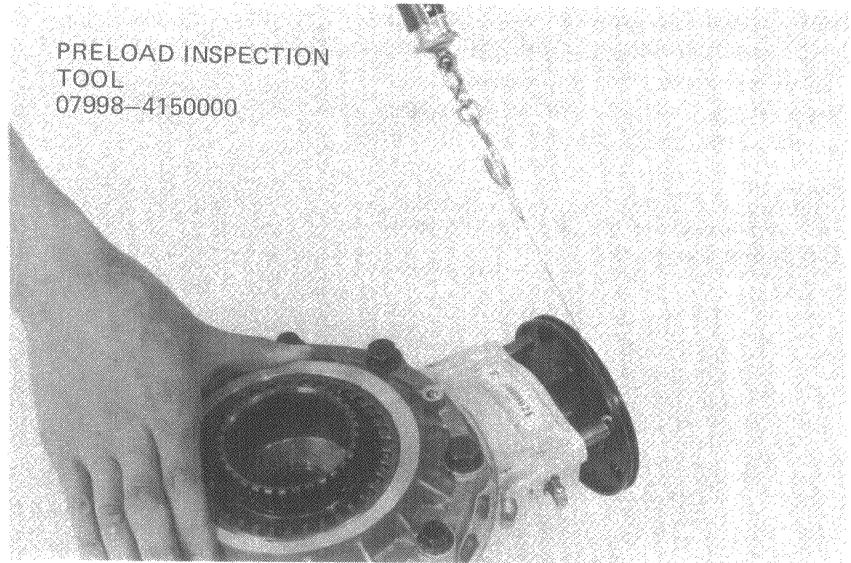

• **GEAR TOOTH CONTACT PATTERN CHECK**

Remove the oil filler cap from the final gear case.

Check the gear tooth contact pattern by rotating the ring gear several times in the normal direction of rotation. The gear tooth contact pattern is indicated by Prussian Blue applied to the pinion before assembly.

Contact is normal if the Prussian Blue is transferred to the approximate center of each tooth flank slightly extending toward the toe side.

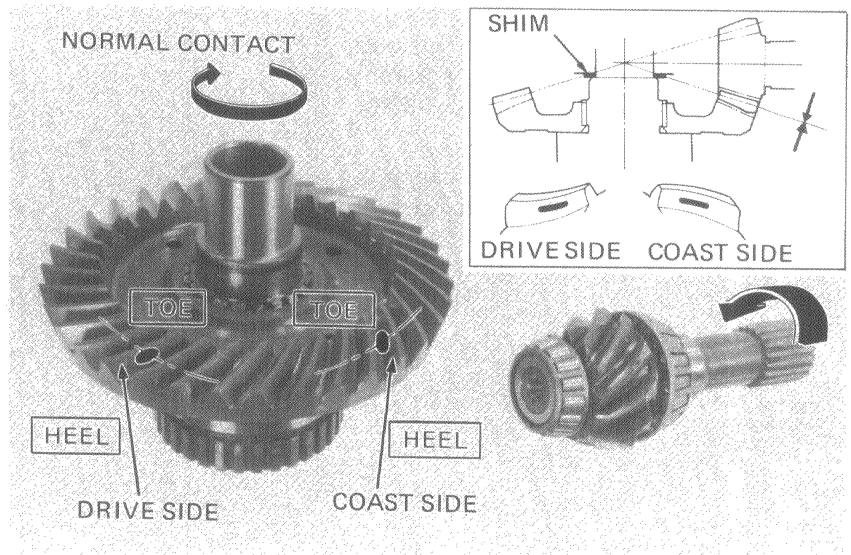

Replace the ring gear shim, if the patterns are not correct.

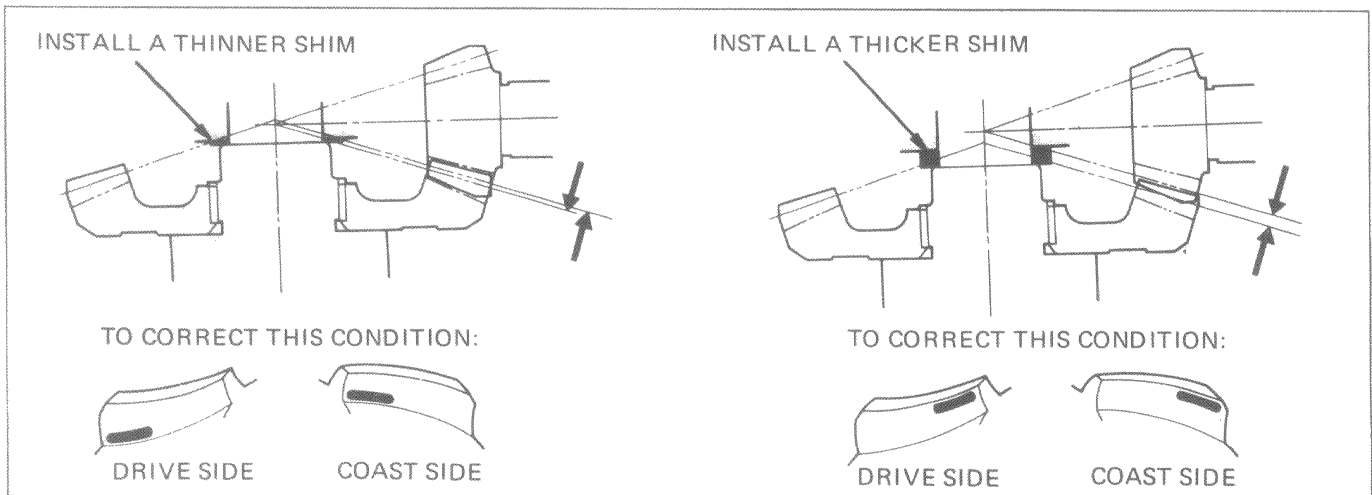





Install the dust plate and torque the bolts.  
Bend the tabs of the lock plates up to prevent the bolts from being turned out during operation.  
Bend one of the four bearing retainer A lock tabs.

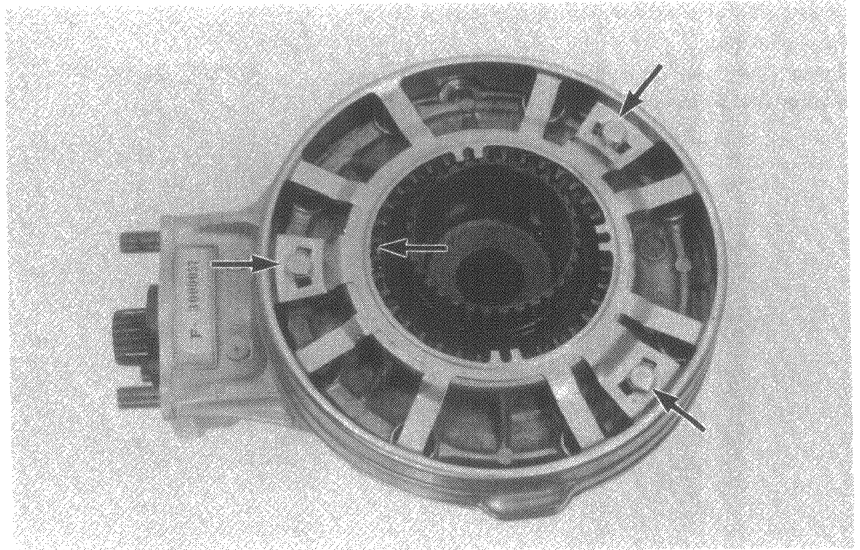

### ● FINAL GEAR CASE INSTALLATION

Lubricate the splines of the propeller shaft and pinion gear shaft with lithium-based multipurpose grease, and engage.

Temporarily install the gear case on the swing arm and rear shock absorber.

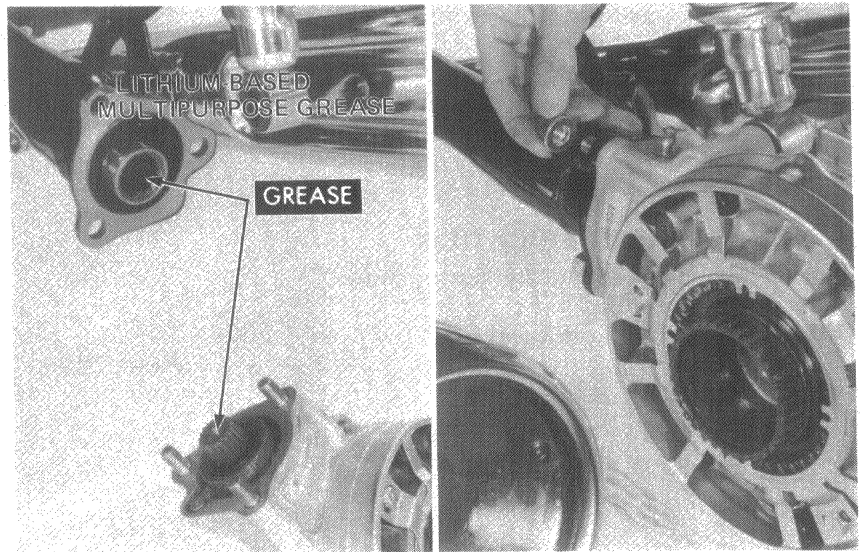

Apply lithium-based multipurpose grease to the splines of the rear wheel and ring gear shaft.  
Insert the distance collar into the ring gear shaft in the direction shown.

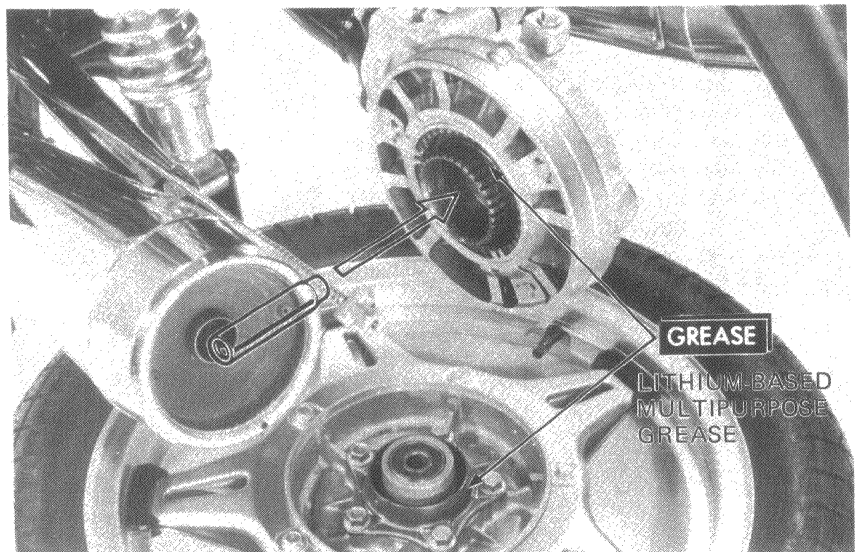



Install the rear wheel and brake panel on the final gear case.

Insert the rear axle through the swing arm, washer, brake panel and rear wheel.

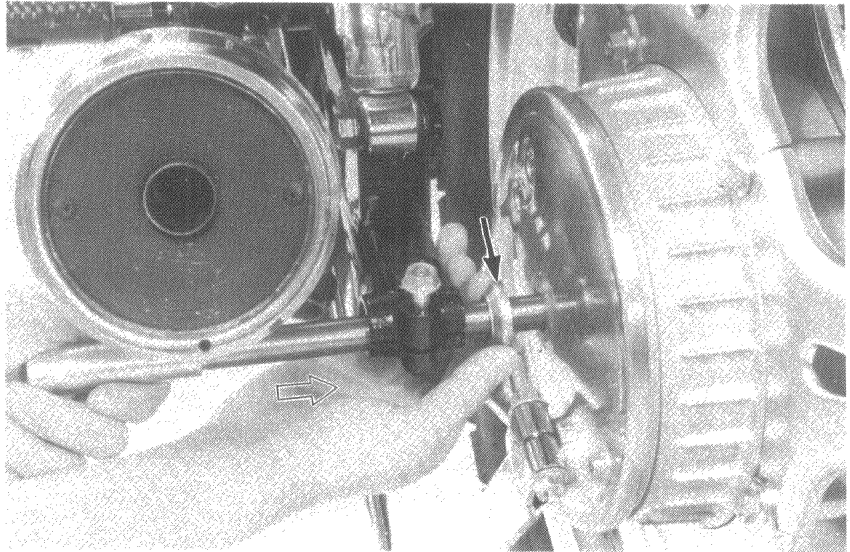

Torque the final gear case to the swing arm and shock absorber mounting nut.

**TORQUE SPECIFICATION:**

**REAR FORK: 4.5–6.0 kg-m (33–44 ft-lbs)**

**REAR SHOCK: 3.0– 4.0 kg-m  
(22– 29 ft-lbs)**

Install the rear wheel. (Page 14–8)

● **PINION GEAR LUBRICATION**

Pump lithium-based multipurpose grease through the grease fitting.

**GREASE QUANTITY: 45 cc approx.**

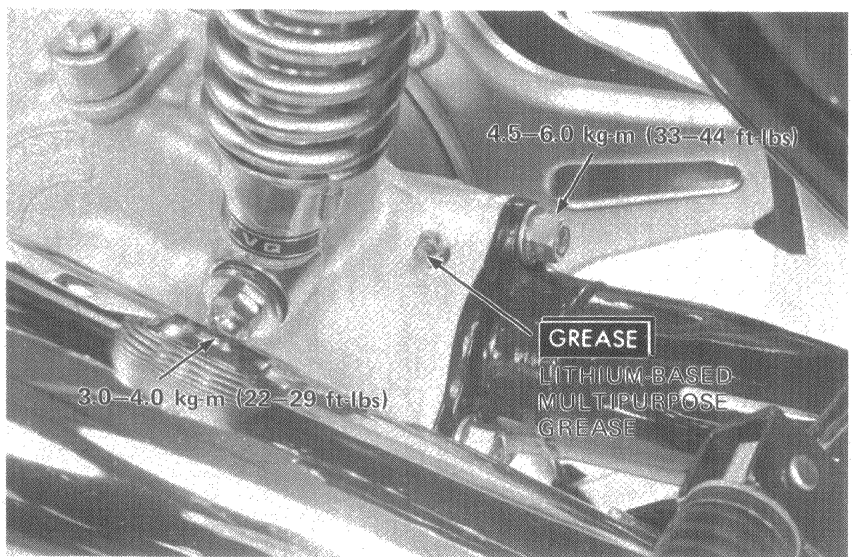

● **FILLING FINAL GEAR CASE**

Place the motorcycle on its center stand.

Make sure that the drain bolt is tightened.

Remove the oil filler cap.

Pour the specified amount of recommended oil up to the filler neck.

**RECOMMENDED OIL: HYPOID GEAR OIL**

Over 5°C: SAE 90

Below 5°C: SAE 80

**OIL CAPACITY: 160–180 cc**

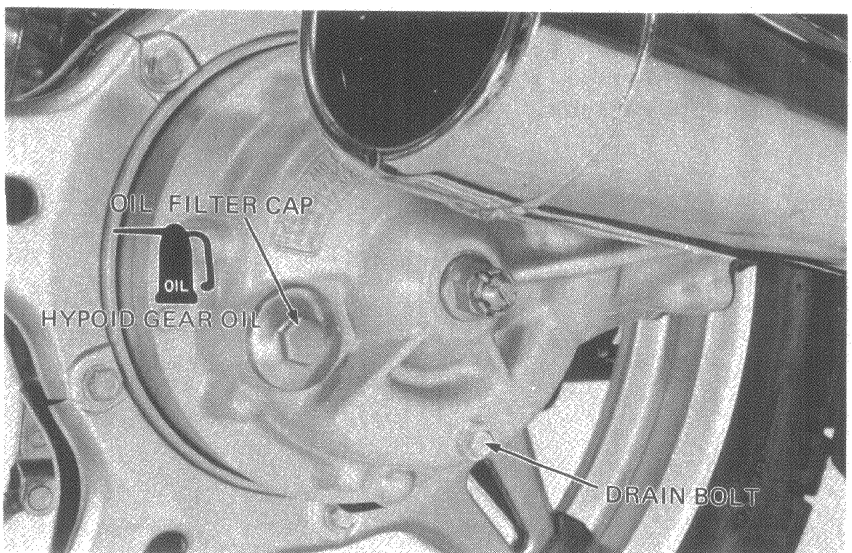





**REAR FORK / PROPELLER SHAFT**

● **SWING ARM/PROPELLER SHAFT  
REMOVAL**

Remove the rear wheel. (Page 14-3)  
Remove the final gear case. (Page 14-12)  
Slide the boot backward and remove the propeller shaft joint bolt.  
Remove the propeller shaft from the engine.  
Remove the left shock absorber.

**CAUTION**

*Pump grease into the final gear case through the grease nipple whenever the propeller shaft is removed from the engine.*

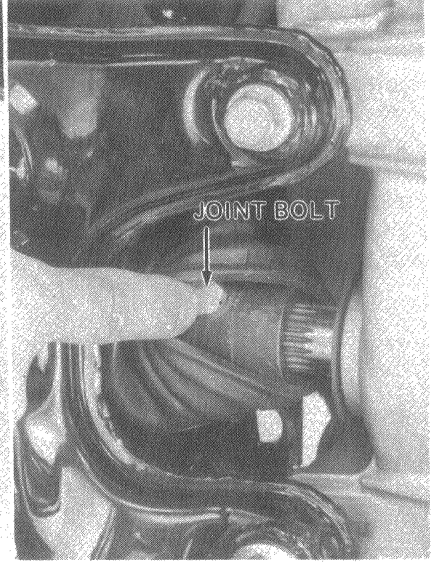
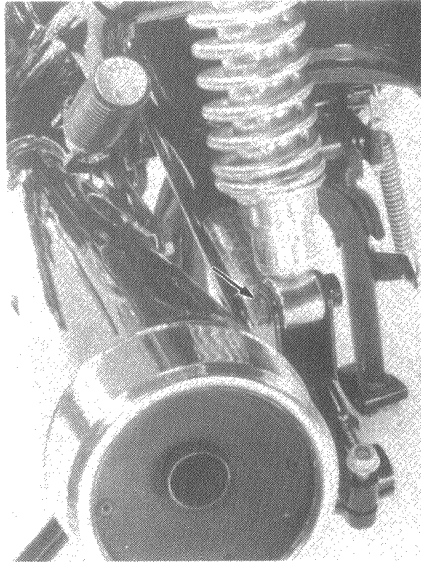

Remove the swing arm pivot bolt from the left.

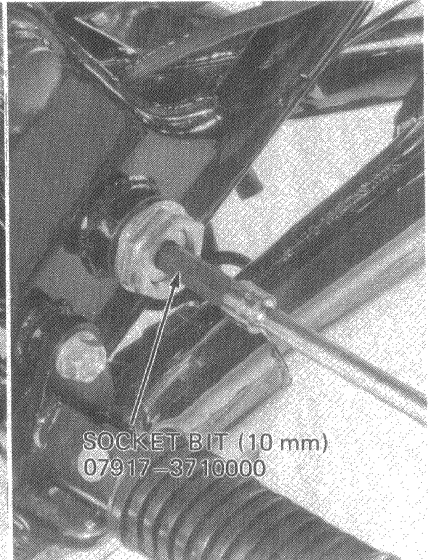
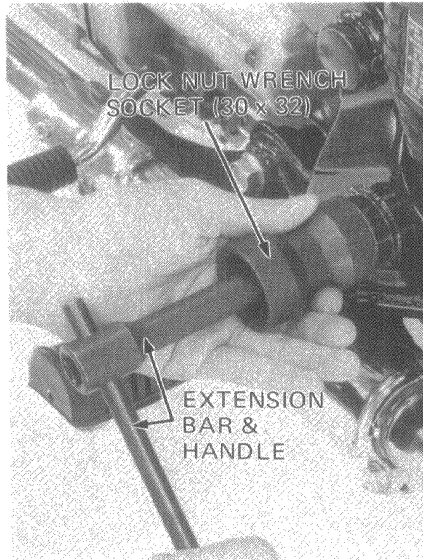

Free the drain tube, etc. from the clamps.  
Remove the right pivot.  
Remove the swing arm and propeller shaft.

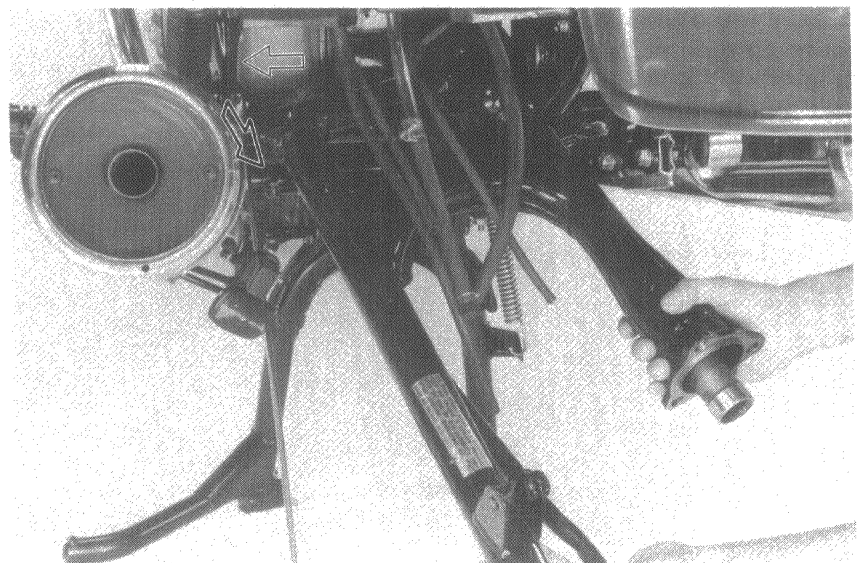



● PROPELLER SHAFT INSPECTION

Remove the boot from the swing arm.  
Remove the drive shaft from the swing arm and inspect the universal joint splines.

Inspect the universal joint. There should be no play in the universal joint bearings.  
Rotate the shaft and joint in opposite directions. If there is any evidence of side play, the shaft must be replaced.

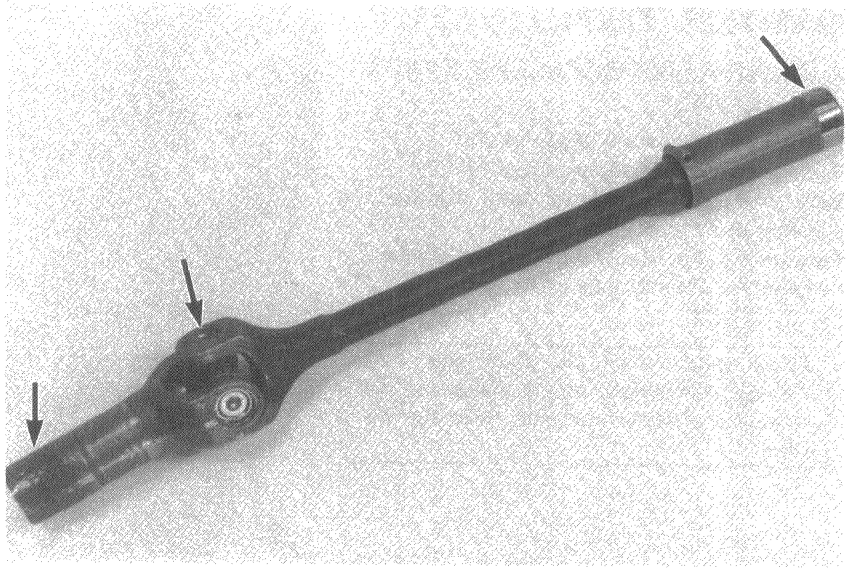

Drive out the spring pin.  
Separate the drive shaft joint from the drive shaft.

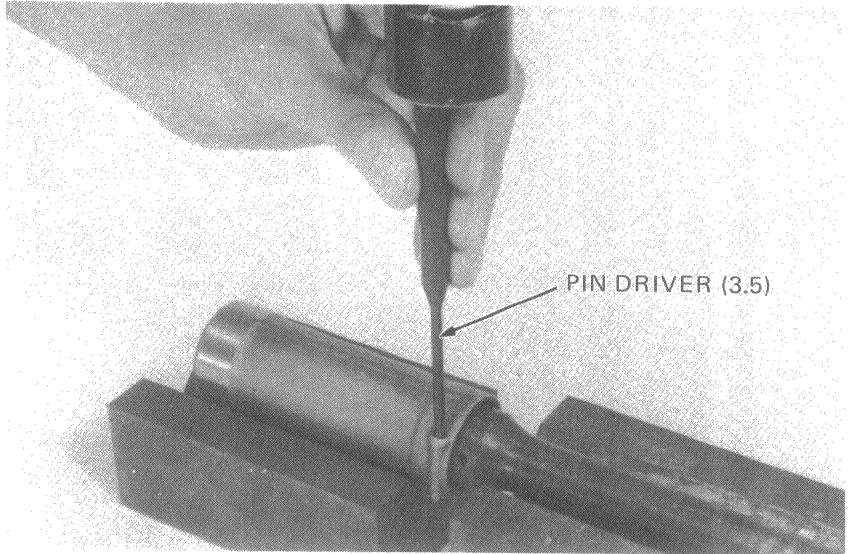

Inspect the drive shaft and drive shaft joint splines for wear and damage.  
Lubricate the splines with lithium-based multipurpose grease.  
Assemble the drive shaft and drive shaft joint and drive in the spring pin.

NOTE

The spring pin should be below the drive shaft joint.

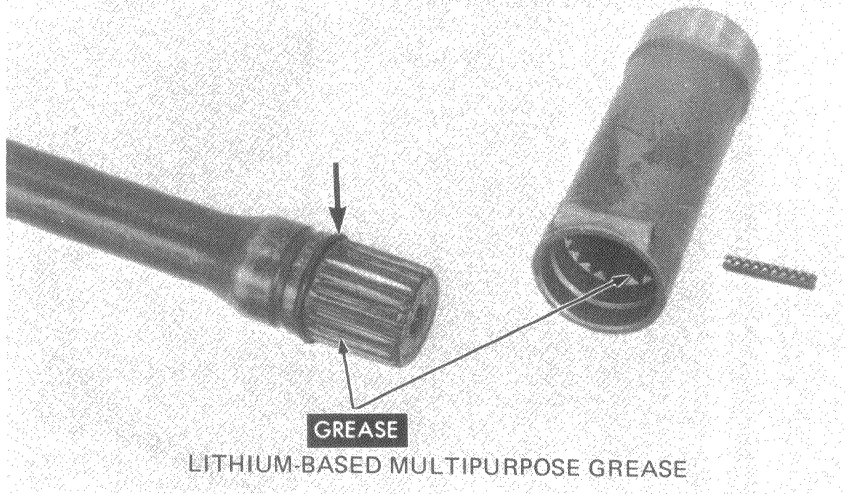





● **PIVOT BEARING INSPECTION  
(LEFT SIDE)**

Cut away the sealing plate using a 12 mm (1/2 in.) drill bit.  
Set the special tool as shown.

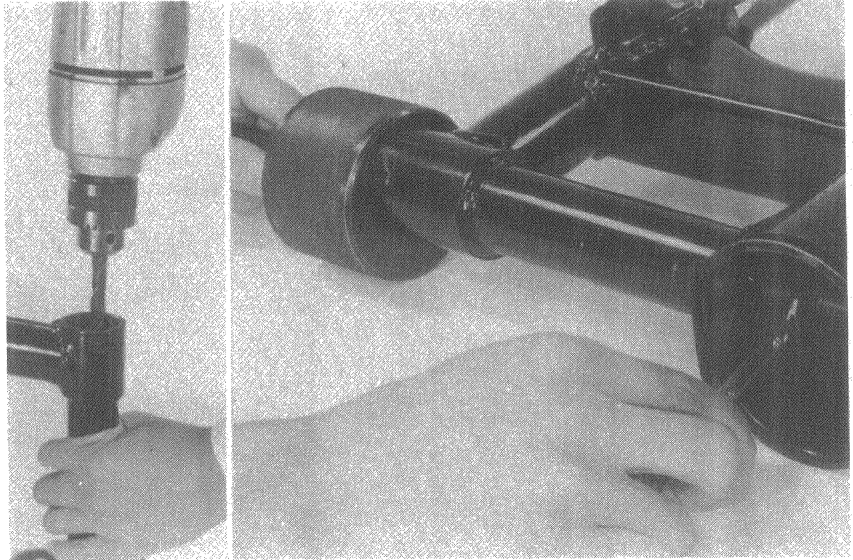

Remove the bearing outer.

**NOTE**

Do not allow the handle to tilt when removing the bearing outer.

Remove the remaining sealing plate and metal saw dust.

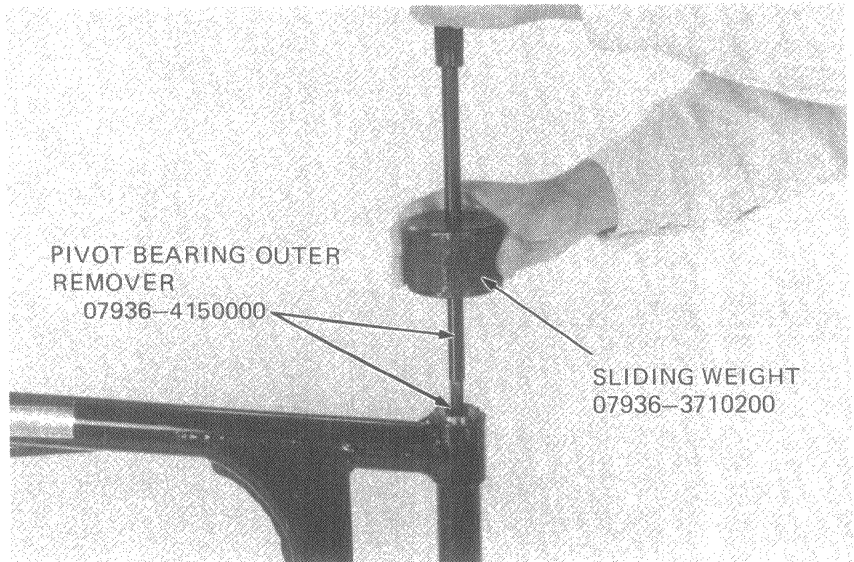

Install a new sealing plate.

**CAUTION**

Install the plate with the dished end facing up.

Install a new bearing outer.

**CAUTION**

Install the bearing outer squarely.

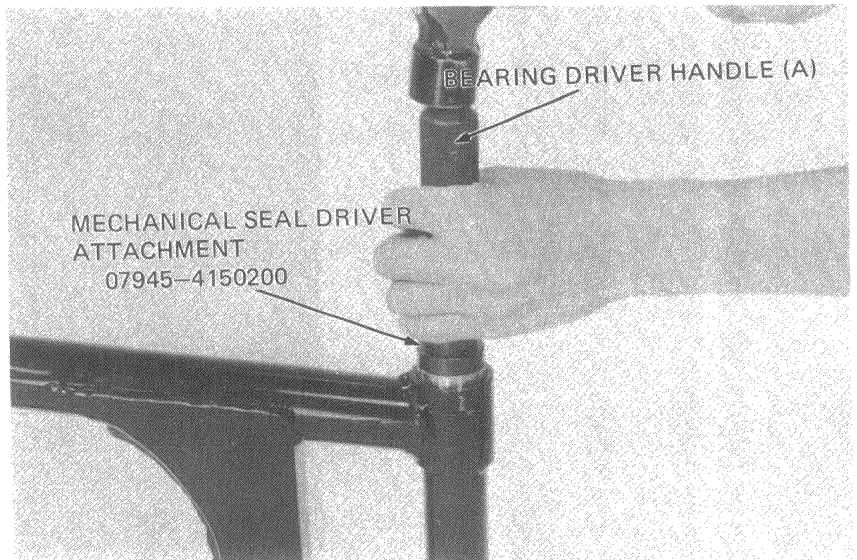



• PIVOT BEARING REPLACEMENT  
(RIGHT SIDE)

Remove the cap and drive the pivot bearing holder out.

**CAUTION**

*Lightly tap the holder with a hammer.*

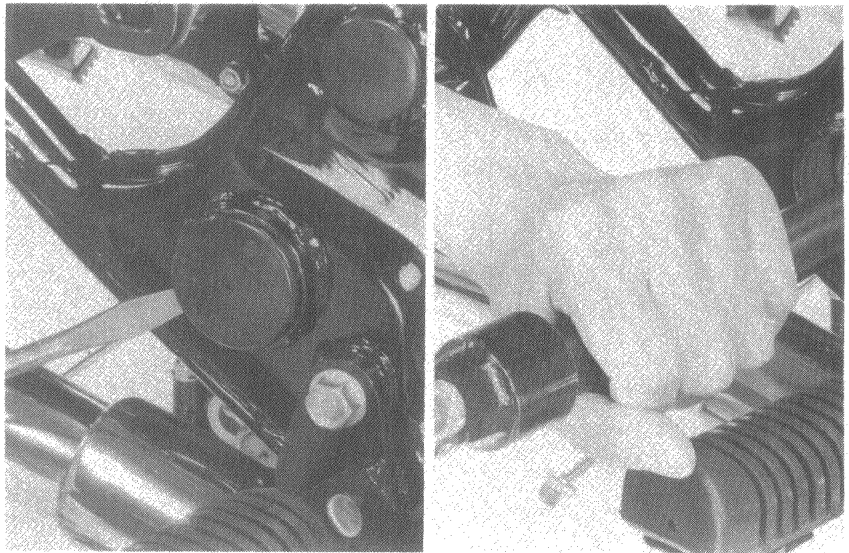

If the bearing outer or inner is damaged, replace it with a new one.

**NOTE**

The bearing inner and outer must be replaced as a set.

Drive the bearing outer into the bearing holder.

**NOTE**

Drive the bearing outer squarely.

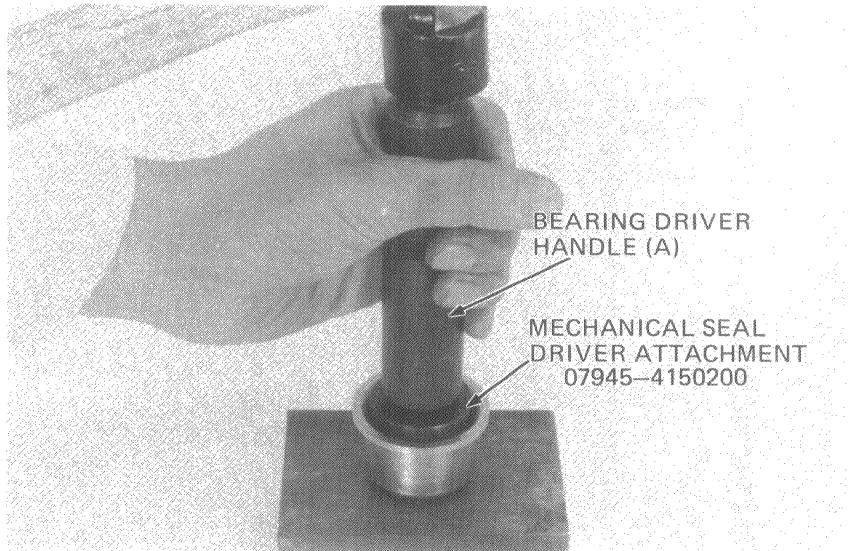

Install the bearing holder so that the flange is seated against the frame body.  
Pack all bearing cavities with grease; apply grease to the oil seal lip.  
Install the bearing and oil seal in the bearing holder.

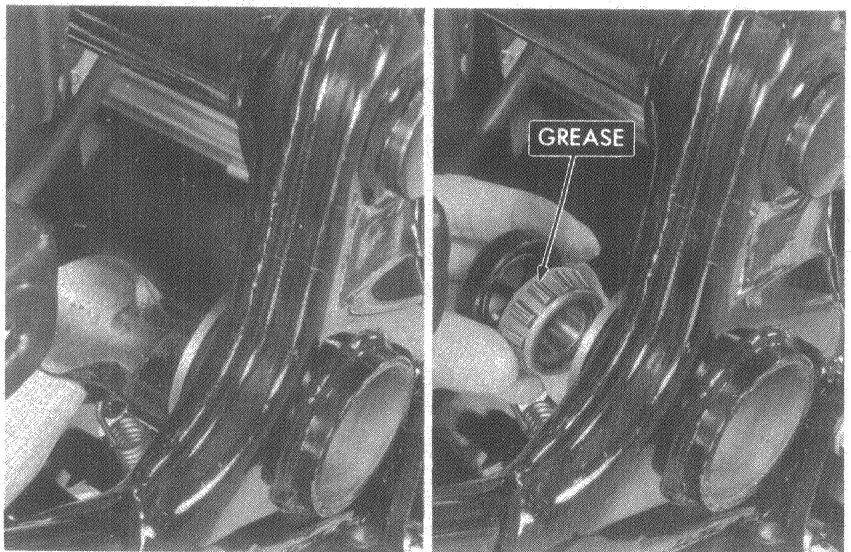





- **SWING ARM/PROPELLER SHAFT  
INSTALLATION**

Install the fork pivot nut from the inside.

**NOTE**

Align with the tab of the fork pivot nut.

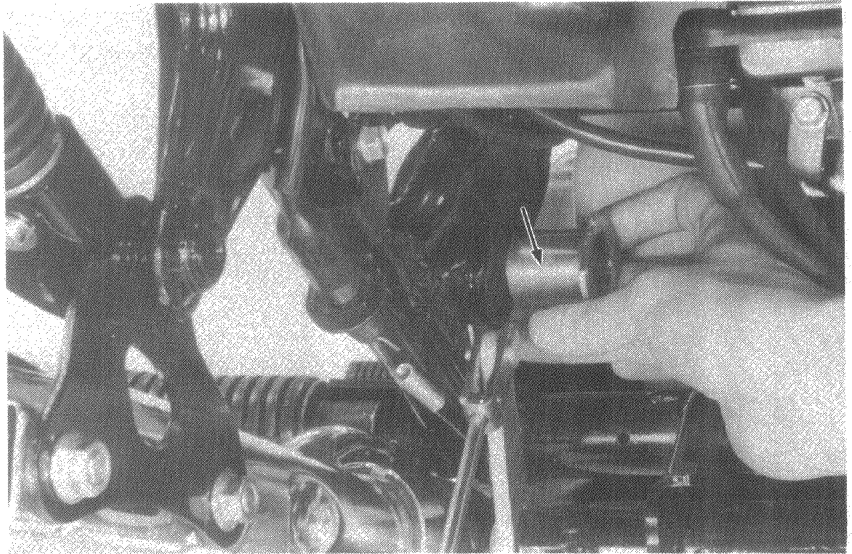

Install the brake torque link on the swing arm.  
Insert the propeller shaft through the swing arm  
and install the boot.

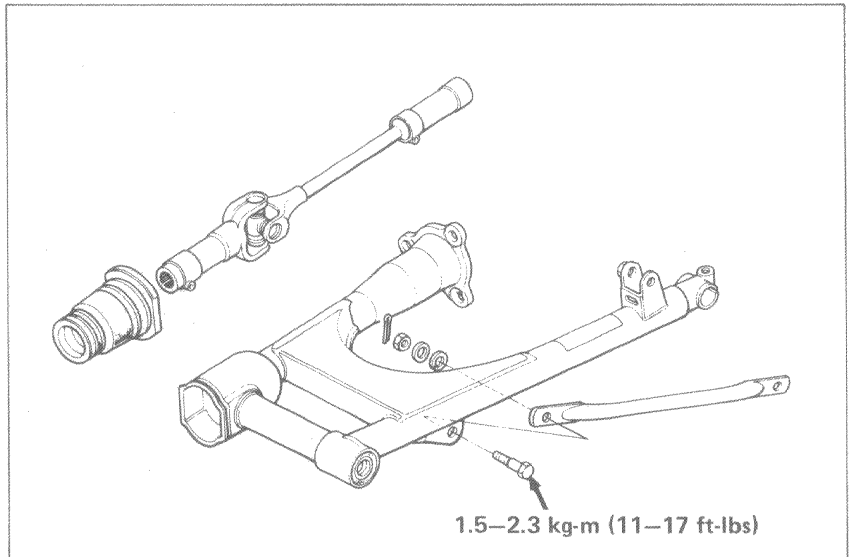

Install the right pivot in the bearing inner.

**NOTE**

Make sure that the right pivot oil seal is  
installed properly.

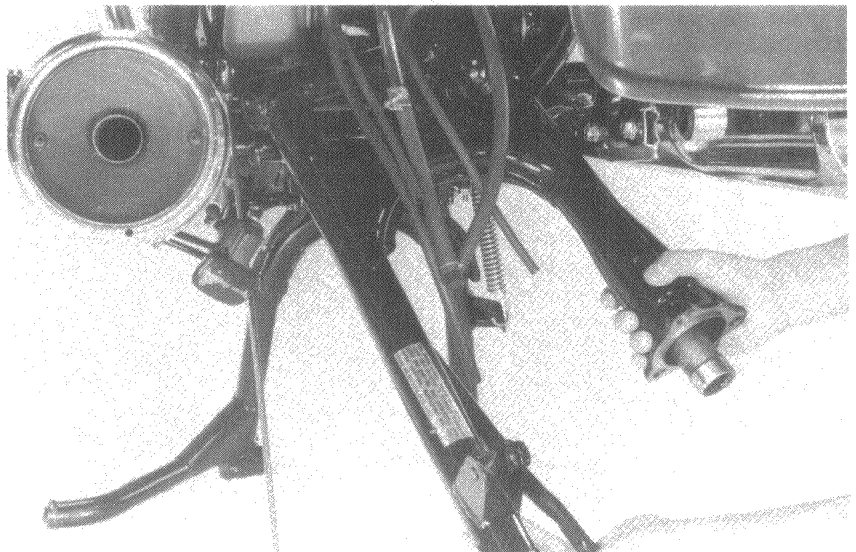



Install the swing arm on the pivot bearing holder from the right side.

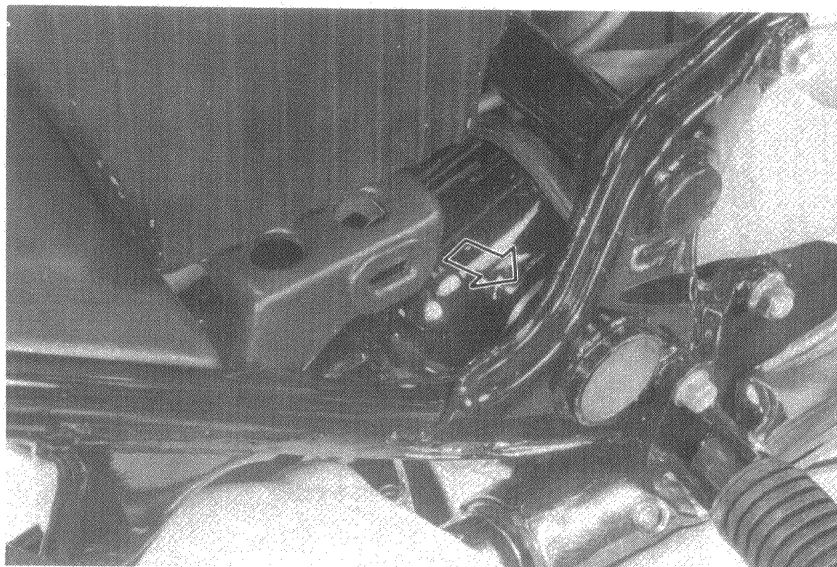

Tighten the pivot bolt gradually.

**NOTE**

Make sure that the end of the pivot bolt is inserted into the bearing inner.

Torque the swing arm pivot bolt.

**TORQUE SPECIFICATION:**  
0.8–1.2 kg-m (6–9 ft-lbs)

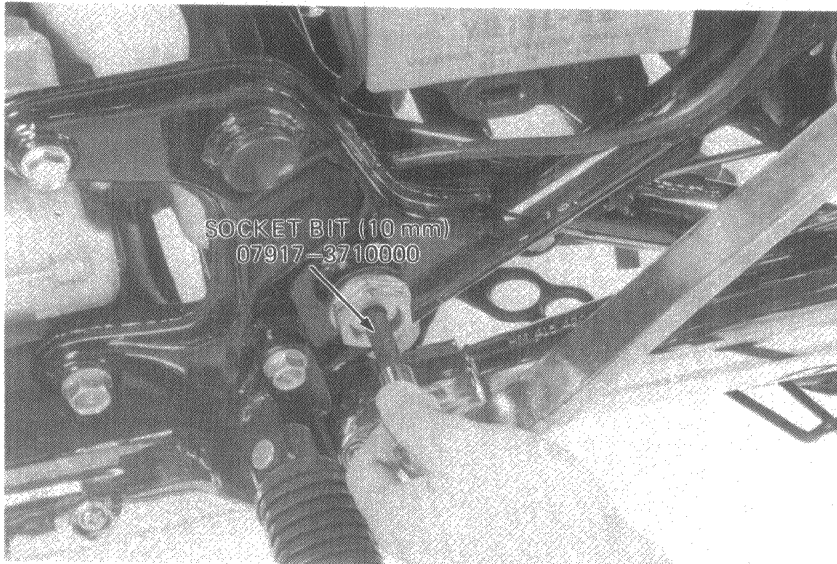

Tighten the lock nut.

**TORQUE SPECIFICATION:**  
8.0–12.0 kg-m (58–87 ft-lbs)

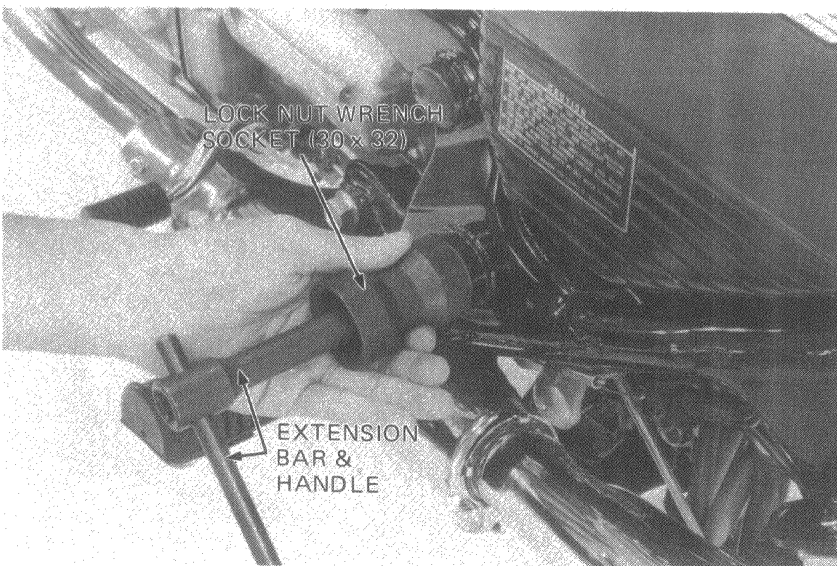





Install the dust cover.

**NOTE**

Align the left dust cover with the lock nut.

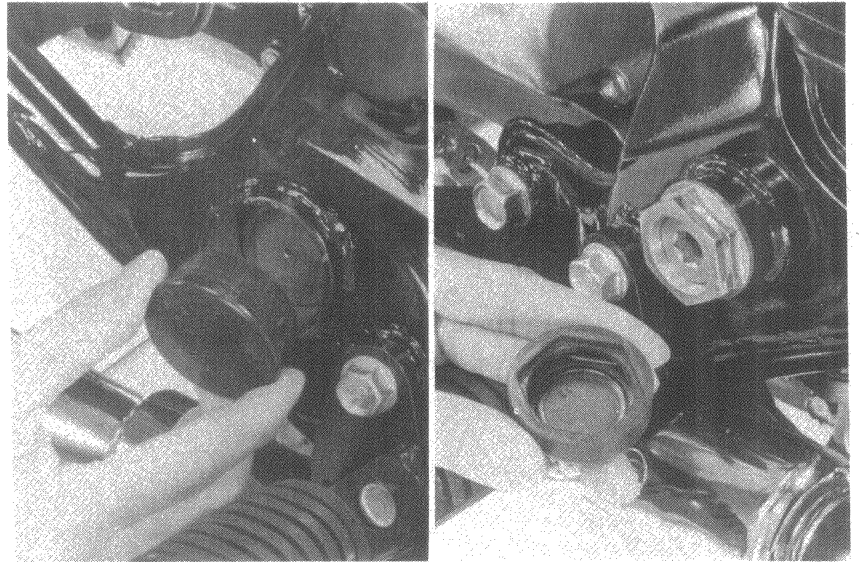

Route the drain tube etc. through the clamps.

**CAUTION**

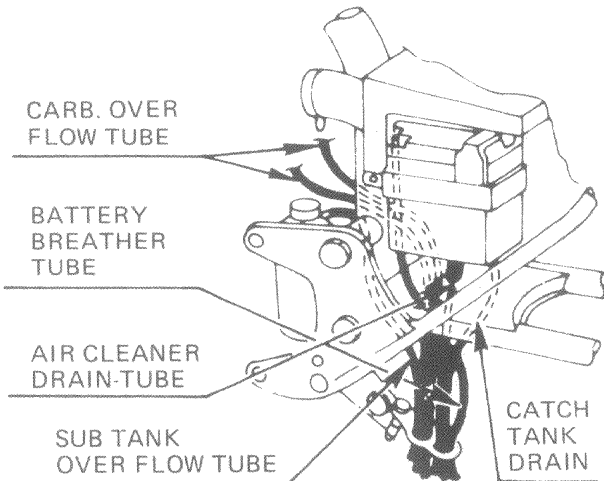

Install the shock absorber.  
Lubricate the final shaft spline with lithium-based multipurpose grease.  
Join the drive shaft and install the boot securely.

**WARNING**

Check that the final shaft does not appear more than 10 mm.

Install the final drive gear case. (Page 14-21)  
Install the rear wheel. (Page 14-8)

**CAUTION**

After installing the final drive case, pump 45 cc of lithium-based multipurpose grease through the grease fitting.

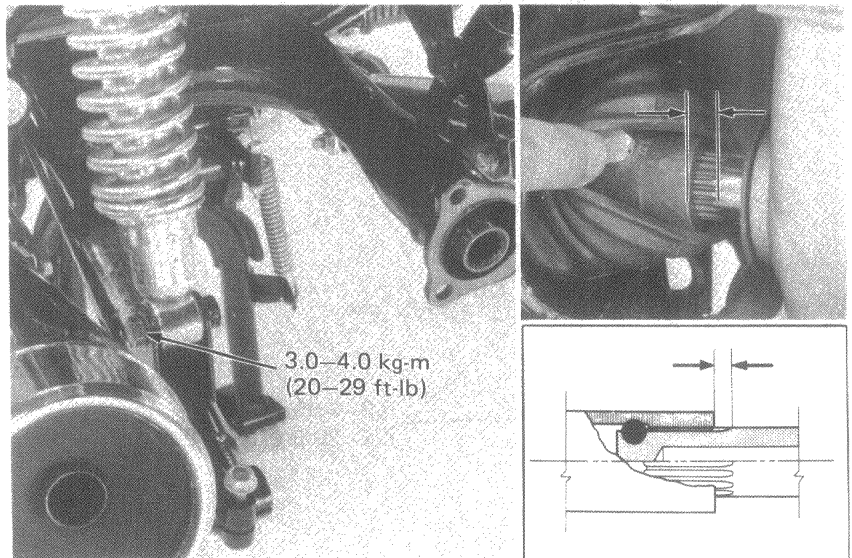



HYDRAULIC DISC BRAKE

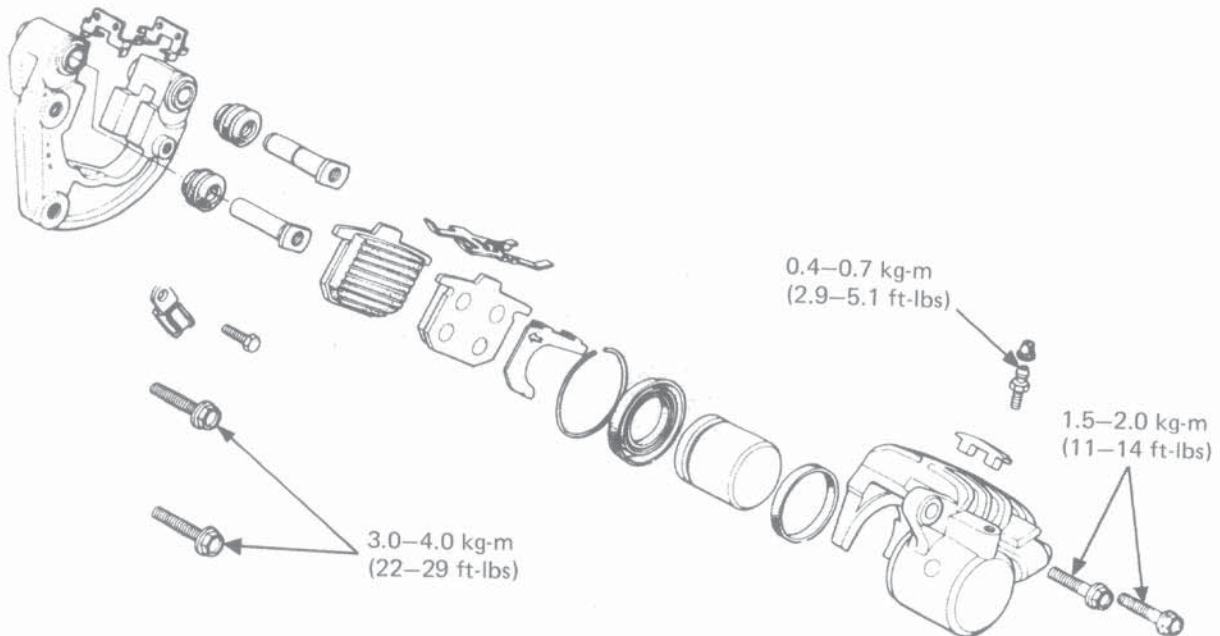
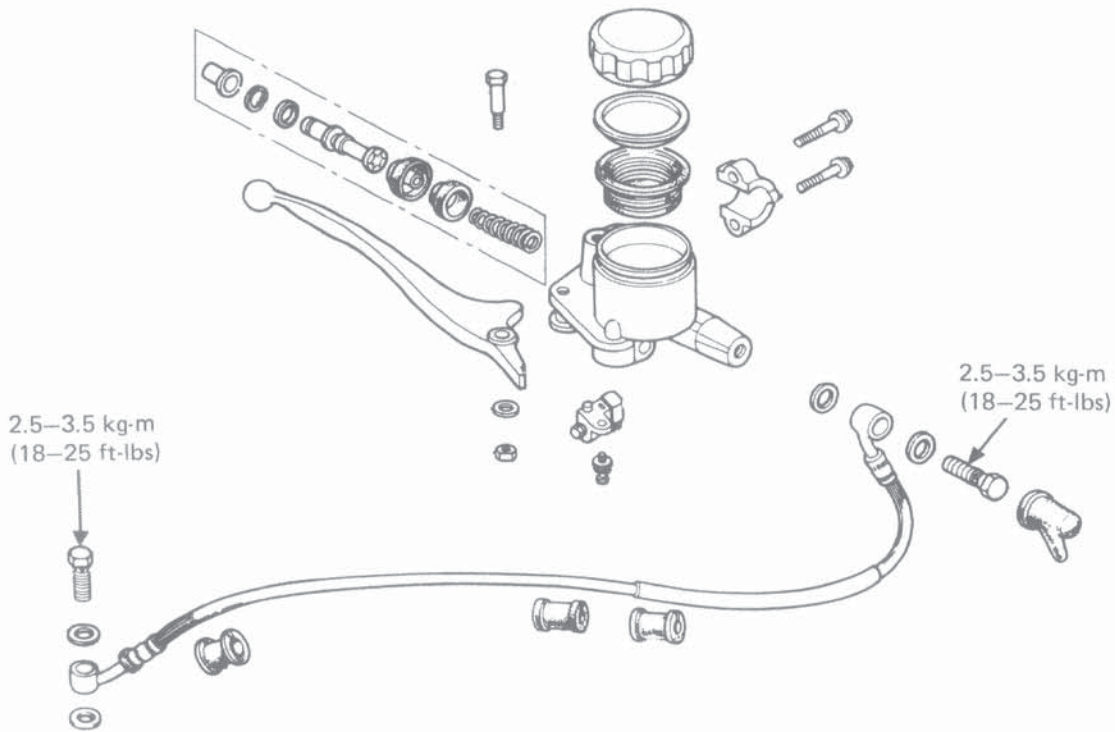





SERVICE INFORMATION	15-1	BRAKE MASTER CYLINDER	15-4
TROUBLESHOOTING	15-1	BRAKE CALIPER	15-6
BRAKE PADS/DISC PLATE	15-2		

## SERVICE INFORMATION

- SPECIAL TOOL  
SNAP RING PLIERS 07914-3230001

- SPECIFICATIONS

	STANDARDS		SERVICE LIMIT	
	mm	in.	mm	in.
Disc thickness	6.8 – 7.2	(0.27 – 0.28)	6.0	(0.24)
Disc runout	—		0.3	(0.012)
Master cylinder I.D.	14.000 – 14.043	(0.5512 – 0.5529)	14.055	(0.5533)
Master piston O.D.	13.957 – 13.984	(0.5495 – 0.5506)	13.940	(0.5488)
Caliper piston O.D.	42.772 – 42.822	(1.6839 – 1.6859)	42.765	(1.6837)
Caliper cylinder I.D.	42.850 – 42.900	(1.6870 – 1.6890)	42.915	(1.6896)

## TROUBLESHOOTING

### Poor Brake Performance

1. Air bubbles in hydraulic system
2. Worn brake pads
3. Pads fouled or glazed
4. Hydraulic system leaking



## BRAKE PADS/DISC PLATE

- BRAKE PAD WEAR CHECK

The front brake pads require replacement if the red line on the top of the pads reaches the edges of the brake disc.

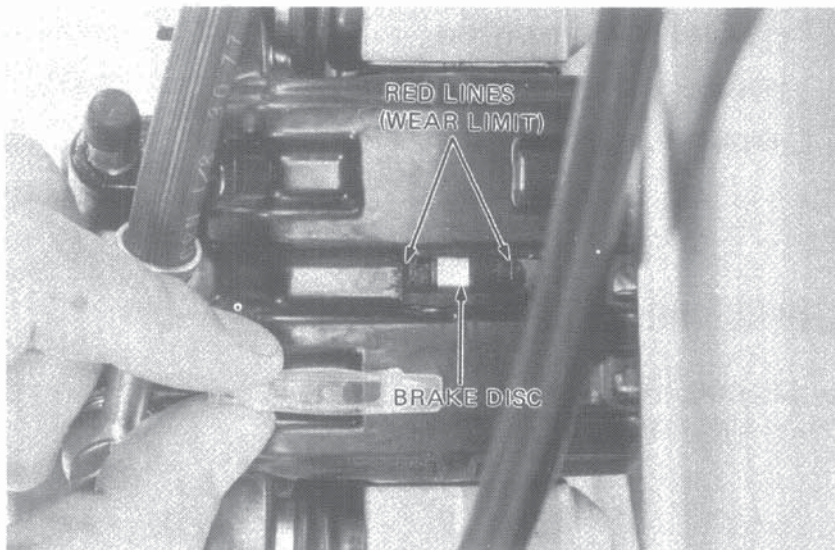

- BRAKE PAD REPLACEMENT

Remove the two brake caliper bolts and remove the caliper.

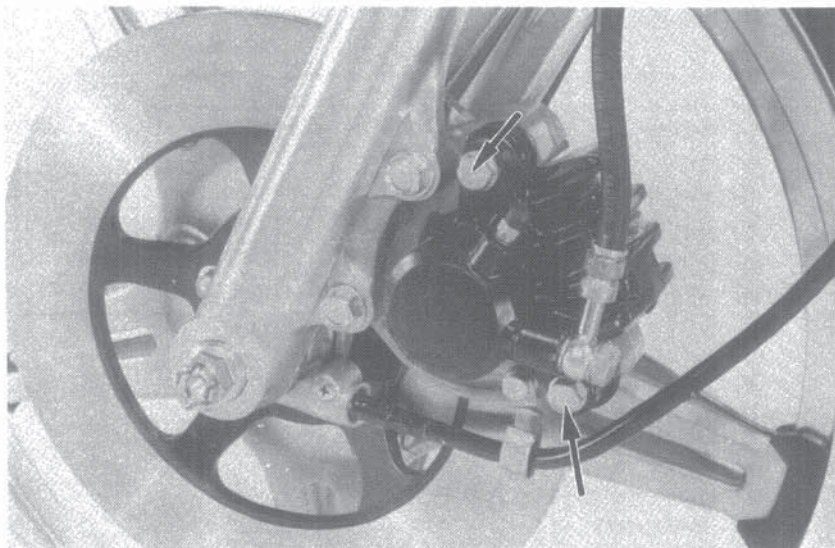

**NOTE**

Always replace the brake pads in pairs to assure even disc pressure.

Install the shim on the piston side pad with the arrow "↖" in the normal direction of disc rotation.

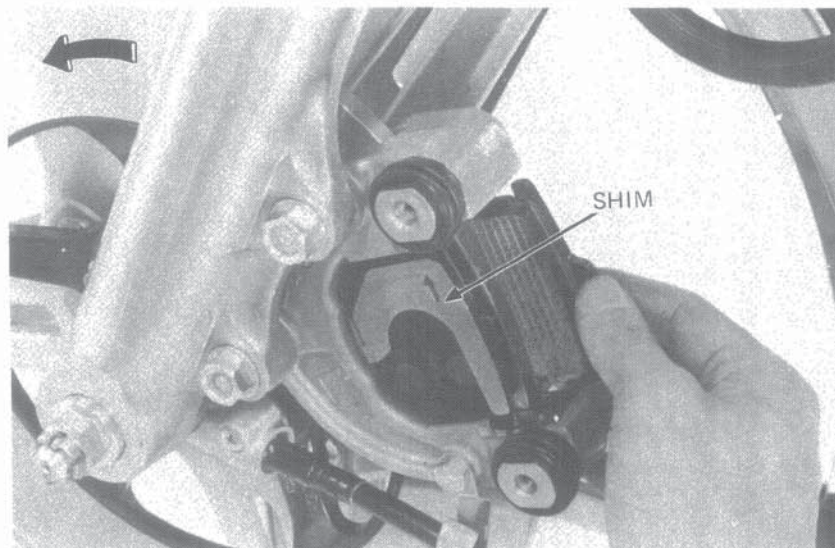





Push the piston all the way in to allow installation of new brake pads.

### NOTE

Check the brake fluid level in the brake master cylinder reservoir as such operation causes the level to rise.

Inspect the piston boot for damage or brittleness.



Insert the pin through the caliper bracket with the chamfered end facing as shown. Inspect the condition of the dust covers. Reinstall the brake caliper.

### NOTE

Tighten the bolts, noting the mating faces of the caliper and pin.

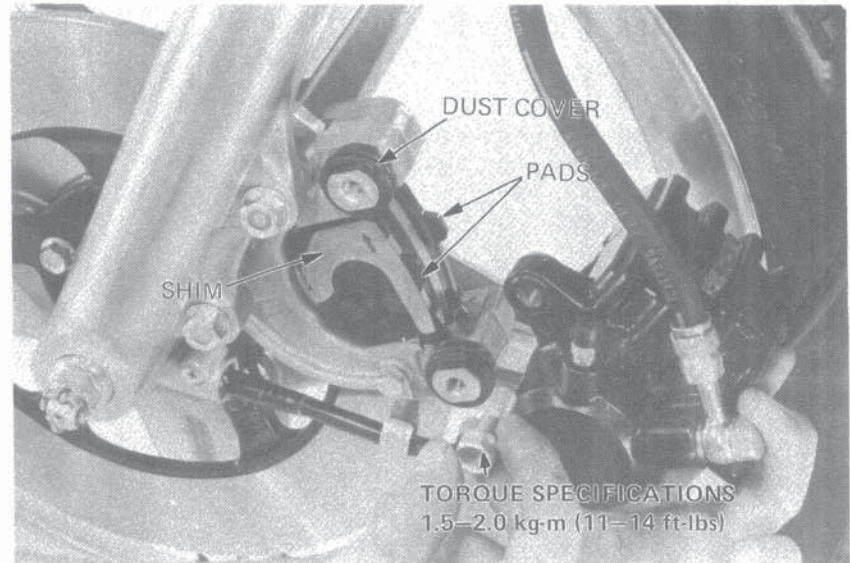

### ● BRAKE DISC THICKNESS

Measure the brake disc thickness.

**SERVICE LIMIT: 6.0 mm (0.24 in.)**

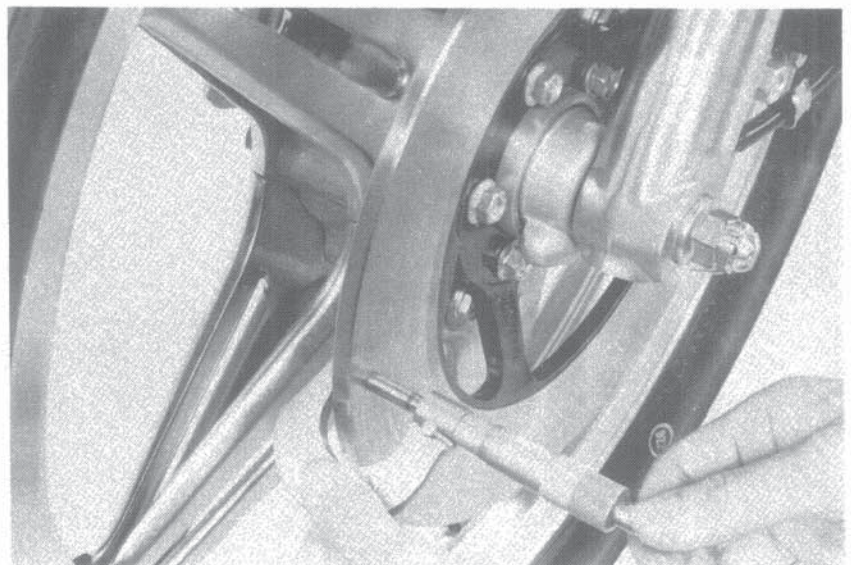





**HYDRAULIC DISC BRAKE**

• **BRAKE DISC WARPAGE**

Measure the brake disc warpage.  
**SERVICE LIMIT: 0.3mm (0.012 in.)**

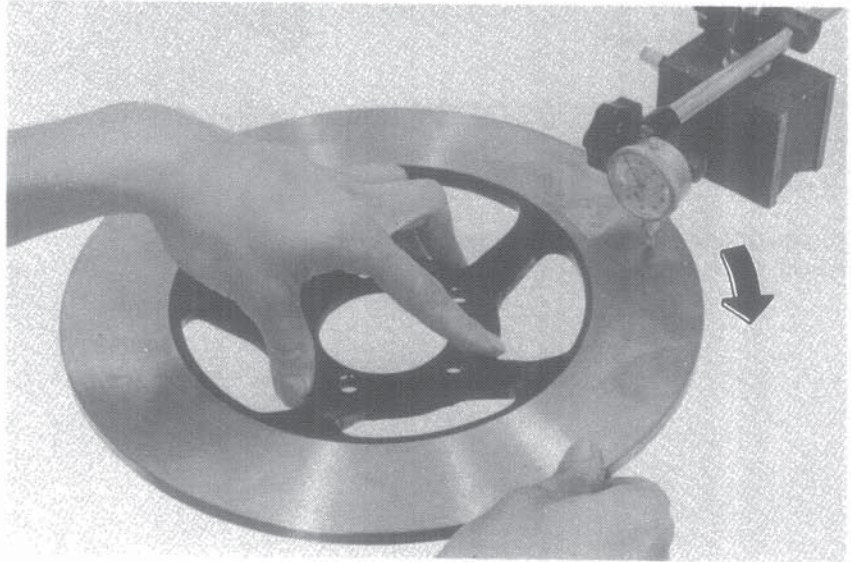

**BRAKE MASTER CYLINDER**

• **MASTER CYLINDER DISASSEMBLY**

Drain brake fluid from the hydraulic system.  
Remove the brake lever from the master cylinder.  
Disconnect the brake hose.

**CAUTION**

*Avoid spilling brake fluid on painted surfaces.  
Place a rag over the fuel tank and instrument whenever the brake system is serviced.*

Remove the master cylinder.

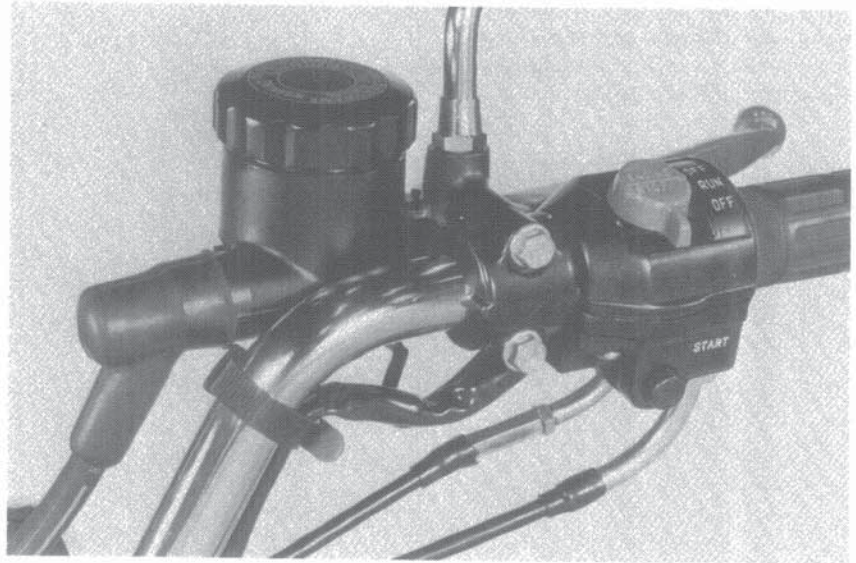

Remove the snap ring.  
Clean the interior of the master cylinder and reservoir with brake fluid.

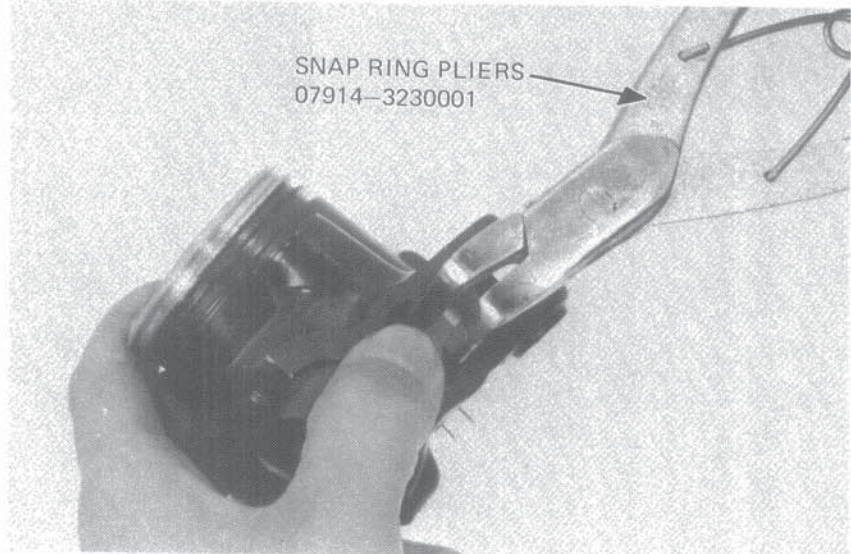





- MASTER CYLINDER I.D. INSPECTION

Measure the master piston bore I.D.

**SERVICE LIMIT: 14.055 mm (0.5533 in.)**

Check for scores, scratches, nicks or other damage.

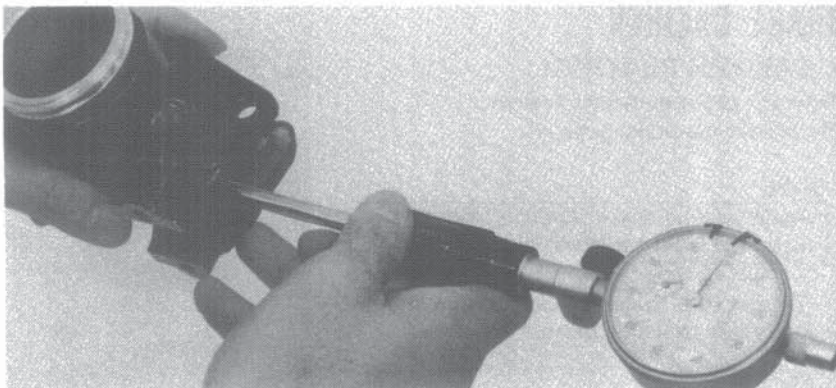

- MASTER PISTON O.D. INSPECTION

Measure the master piston O.D.

**SERVICE LIMIT: 13.940 mm (0.5488 in.)**

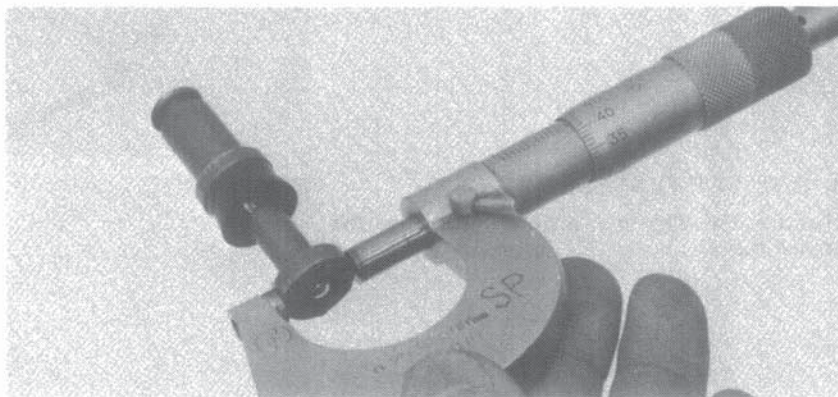

- MASTER CYLINDER ASSEMBLY

**CAUTION**

*Replace the master cylinder piston, cylinder and spring as a set.*

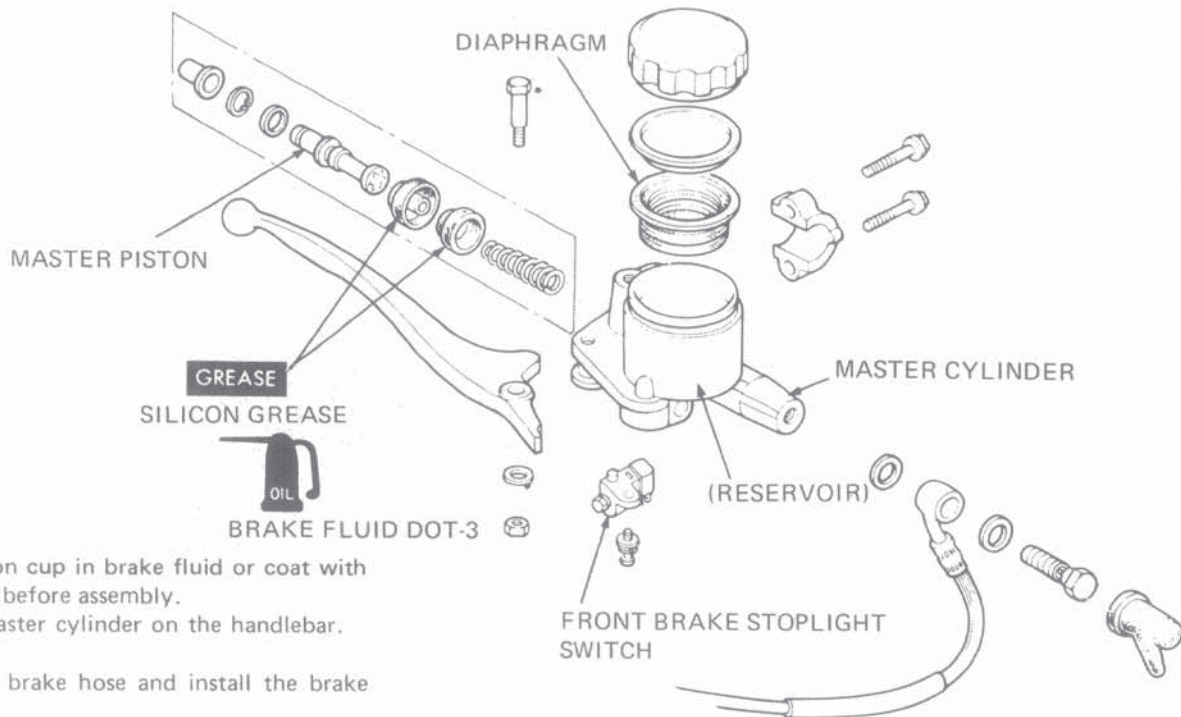

Dip the piston cup in brake fluid or coat with silicon grease before assembly.

Install the master cylinder on the handlebar. (Page 13-4).

Connect the brake hose and install the brake lever.

Bleed the front brake system. (Page 3-10)





**HYDRAULIC DISC BRAKE**

**BRAKE CALIPER**

• **CALIPER REMOVAL**

Drain the brake hydraulic system.  
Disconnect the brake hose.

**NOTE**

Avoid spilling brake fluid on painted surfaces, the front forks and disc plate.

To remove the brake caliper, loosen the two brake caliper attaching bolts.

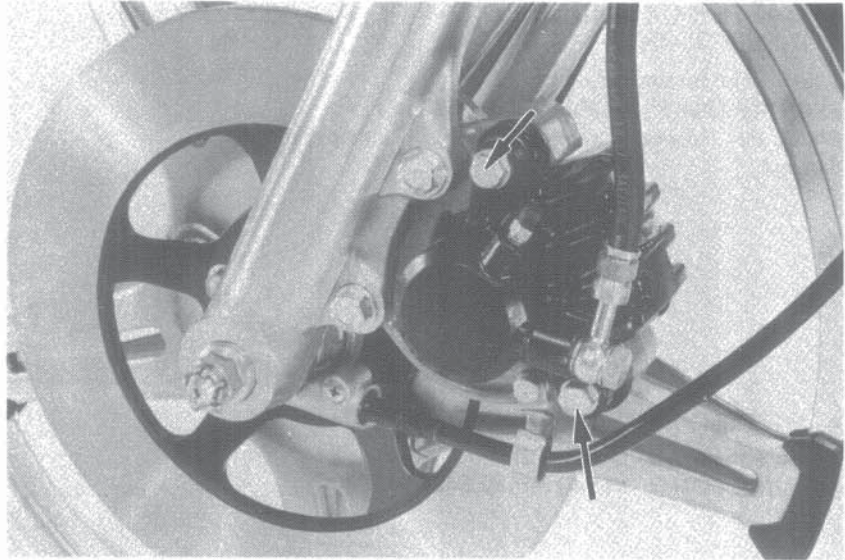

• **CALIPER DISASSEMBLY**

Remove the clip and piston boot from the caliper piston.

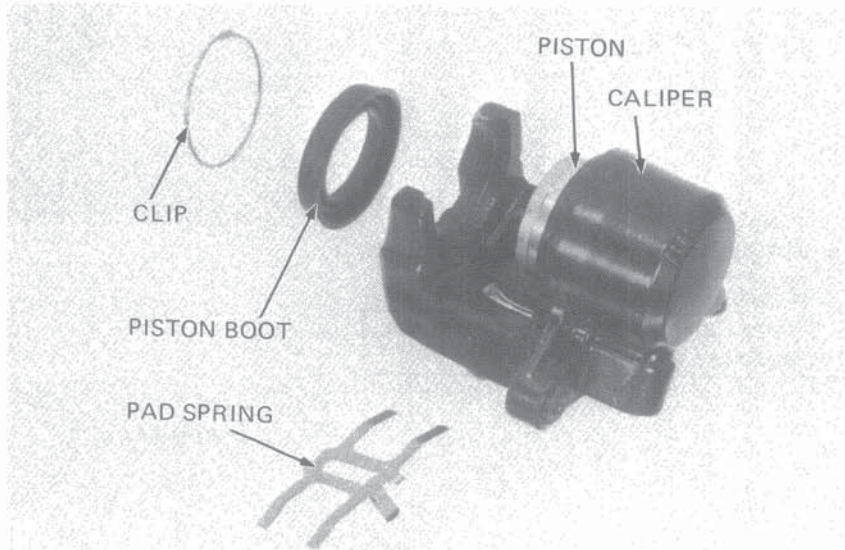

Place a shop towel or rag over the piston to prevent the piston from coming out, and position the caliper with the piston down.

Apply a small amount of air pressure to the fluid inlet.

**WARNING**

*Do not use high pressure air or bring the nozzle too close to the inlet.*

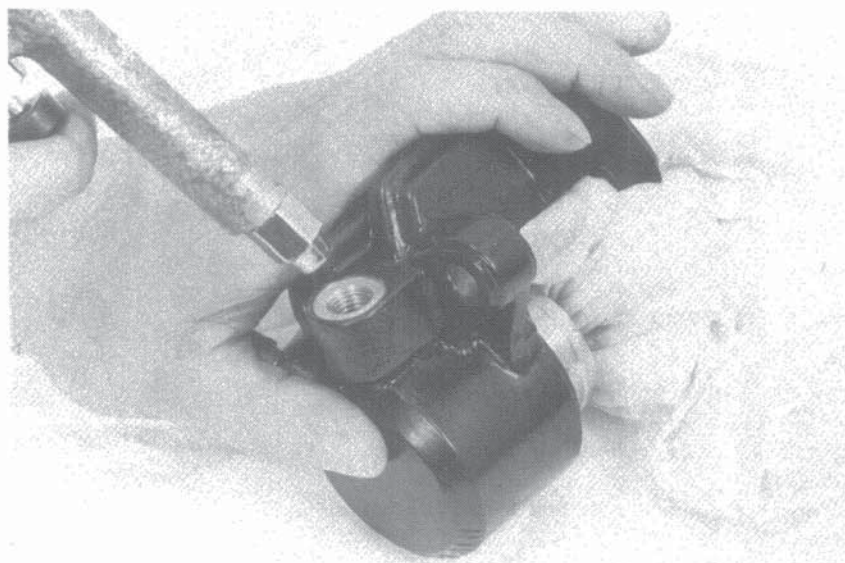





Lift out the oil seal by pushing it into the cylinder as shown.

Clean the caliper grooves with brake fluid.

Replace the oil seal whenever the caliper is disassembled.

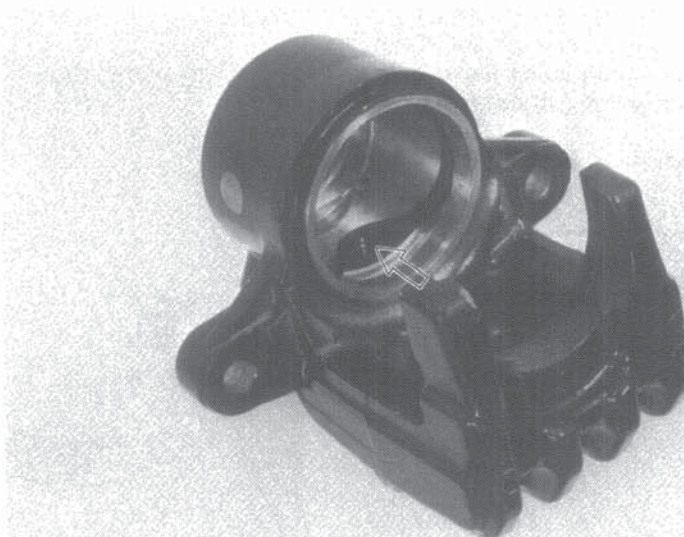

• **CALIPER CYLINDER I.D. INSPECTION**

Check the caliper cylinder for scoring, scratches or other damage. Measure the caliper cylinder bore I.D..

**SERVICE LIMIT: 42.915 mm (1.6896 in.)**

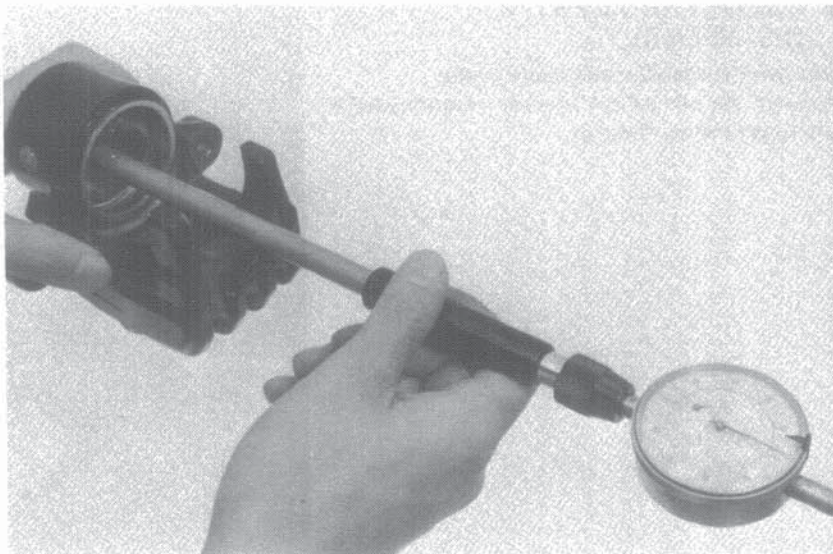

• **CALIPER PISTON O.D. INSPECTION**

Check the piston for scoring, scratches or other damage. Measure the caliper piston diameter.

**SERVICE LIMIT: 42.765 mm (1.6837 in.)**

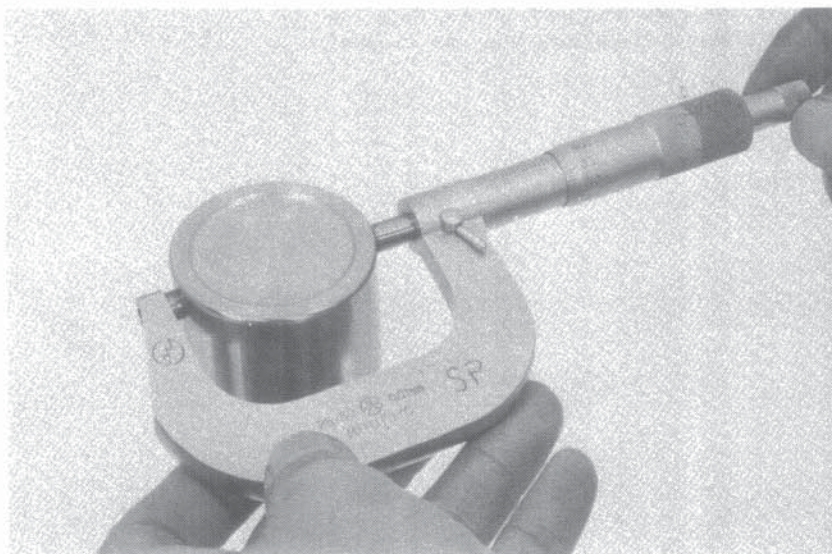





**HYDRAULIC DISC BRAKE**

• **BRAKE CALIPER ASSEMBLY**

Wash the parts with brake fluid. Coat the O-rings with silicon grease or brake fluid and install the piston with the dished end facing the brake pad.

Install the piston boot and clip on the piston.

**NOTE**

Make sure that the clip is installed securely.

Install the pad spring as indicated.

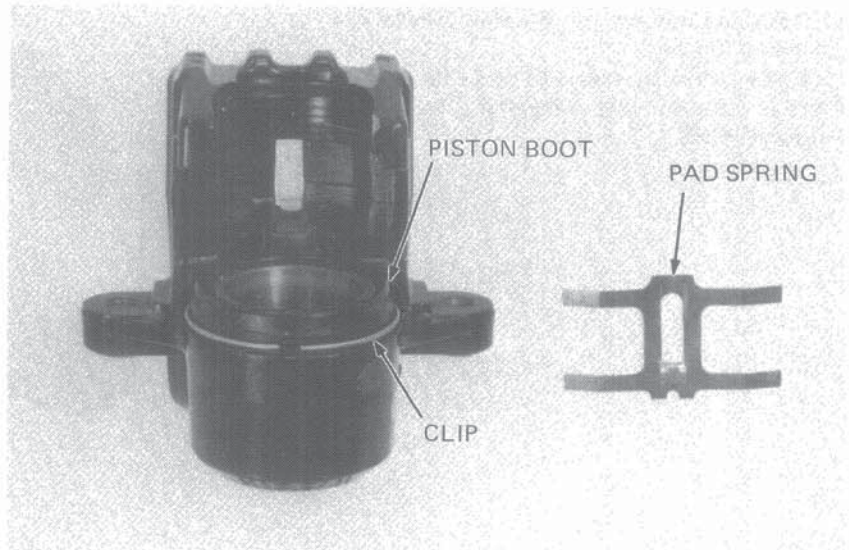

• **CALIPER BRACKET DISASSEMBLY**

Remove the speedometer cable clamp.  
Remove the two caliper bracket mounting bolts and brake caliper bracket.

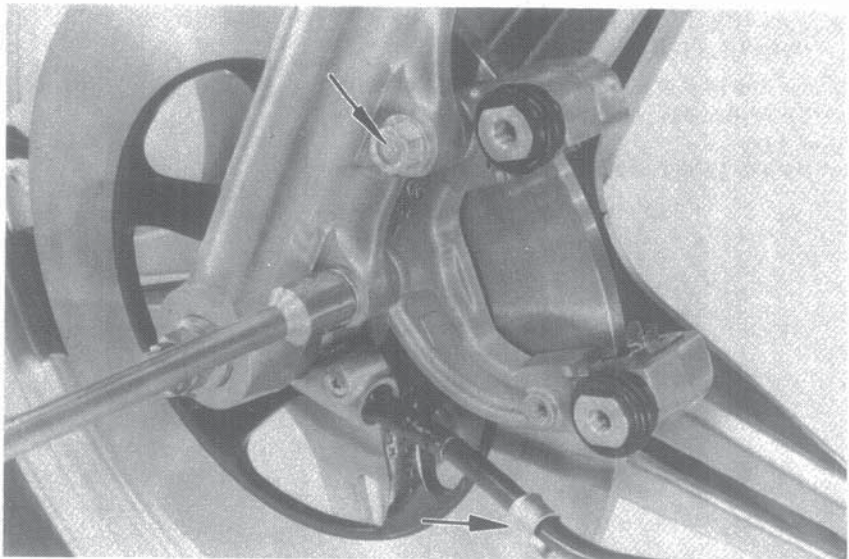

Remove the pins and dust covers from the caliper bracket. Make sure they are in good condition.

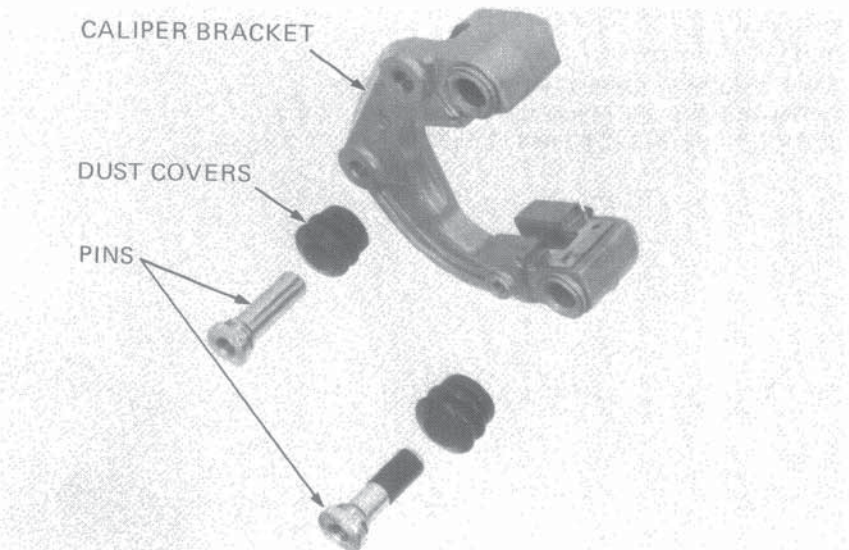





• CALIPER BRACKET ASSEMBLY

Wash all the removed parts. Coat the pins with silicon grease or brake fluid.

Put the dust covers over the pins and install the pins in the caliper bracket.

NOTE

Make sure the dust covers are seated properly.

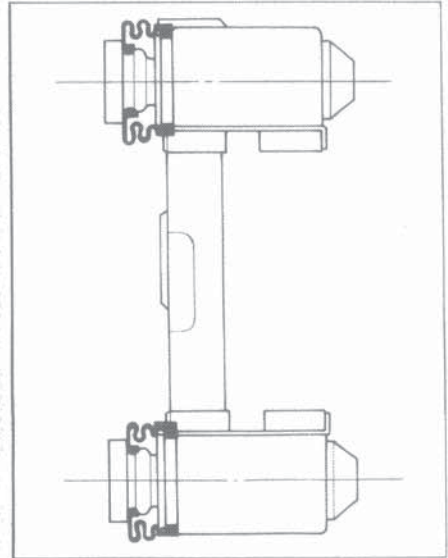
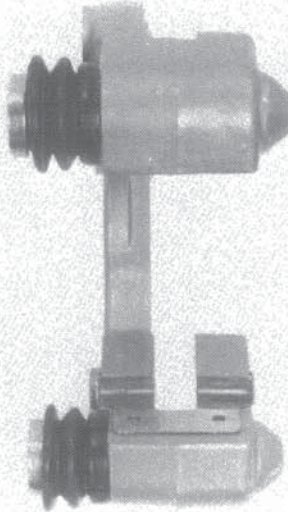

Install the caliper bracket on the front fork. Position the pins with the flats positioned as shown.

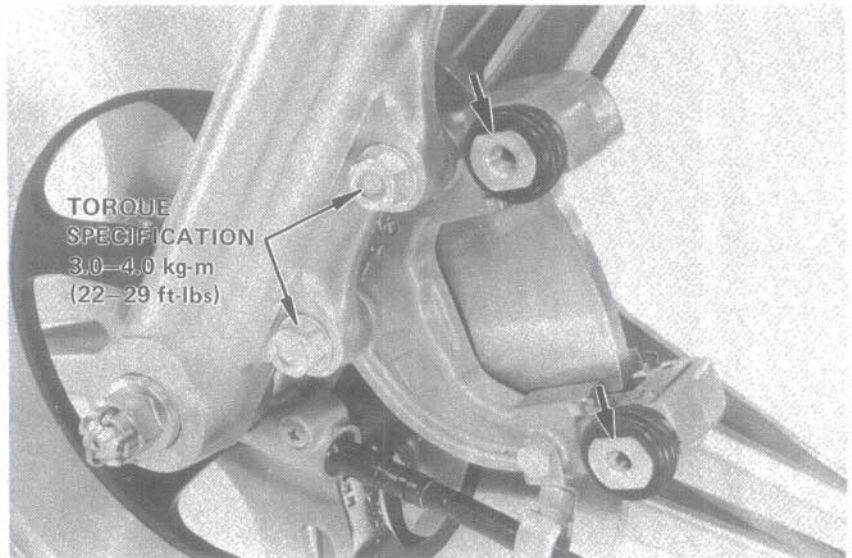

TORQUE SPECIFICATION  
3.0-4.0 kg-m  
(22-29 ft-lbs)

• BRAKE CALIPER INSTALLATION

Connect the brake hose to the brake caliper and install the bleeder screw.

Install the brake caliper.

NOTE

Tighten the shafts carefully, aligning the mating faces of the calipers.

Bleed the brake system (Page 3-10).

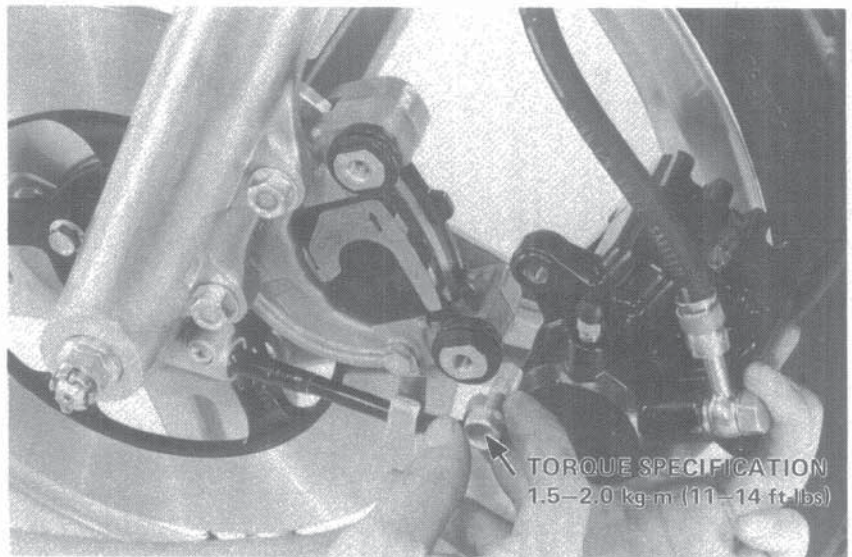

TORQUE SPECIFICATION  
1.5-2.0 kg-m (11-14 ft-lbs)



SERVICE INFORMATION	16-1
TROUBLESHOOTING	16-2
BATTERY	16-3
CHARGING SYSTEM	16-4
A.C. GENERATOR REMOVAL/ INSTALLATION	16-6

## SERVICE INFORMATION

- WORKING PRACTICE

Battery acid level should be checked regularly, add distilled water when necessary.  
 Quick-charging the battery should only be done in an emergency; slow-charging is preferred.  
 Remove the battery from the motorcycle for charging.  
 Keep fire or sparks away from a charging battery because it produces hydrogen.  
 All charging system components can be tested on the motorcycle.

- SPECIFICATIONS

Battery	Capacity	12V, 14 ampere-hours
	Specific gravity	1.28/20°C (68°F)
	Charging rate	1.4 amperes maximum
AC generator	Capacity	High beam: 5 amperes minimum/5,000 rpm (14.5 volts)
Voltage regulator	Type	Transistorized non-adjustable



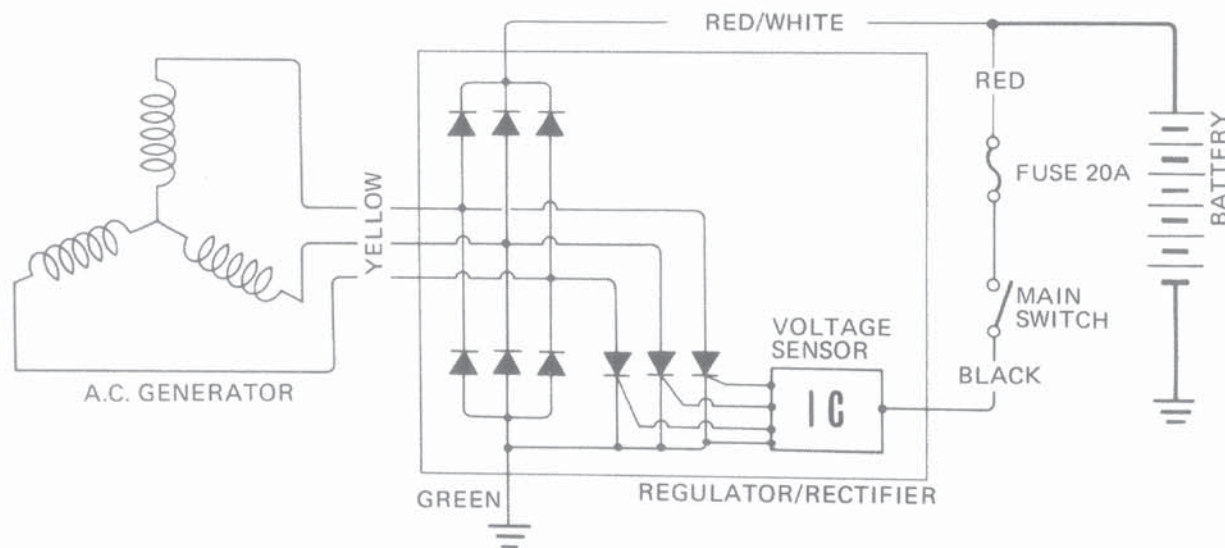

## TROUBLESHOOTING

### No Power — Key Turned On:

1. Dead battery
  - Battery not charged
  - Battery electrolyte evaporated
  - Battery specific gravity low
  - Charging system failure
2. Disconnected battery cable
3. Main fuse burned out
4. Faulty ignition switch

### Low Power — Key Turned On:

1. Weak battery
  - Low battery electrolyte level
  - Battery specific gravity low
  - Charging system failure
2. Loose battery connection

### Low Power — Engine Running

1. Battery undercharged
  - Low battery electrolyte level
  - One or more dead cells
2. Charging system failure

### Intermittent Power:

1. Loose battery connection
2. Loose charging system connection
3. Loose starting system connection
4. Loose connection or short circuit in ignition system
5. Loose connection or short circuit in lighting system

### Charging System Failure:

1. Loose, broken, or shorted wire or connection
2. Faulty voltage regulator
3. Faulty silicon rectifier
4. Faulty A.C. generator



### BATTERY

#### ● REMOVAL

Disconnect the ground cable.  
 Remove the battery holder.  
 Disconnect the positive (+) cable at the battery.  
 Disconnect the battery breather tube, and remove the battery.

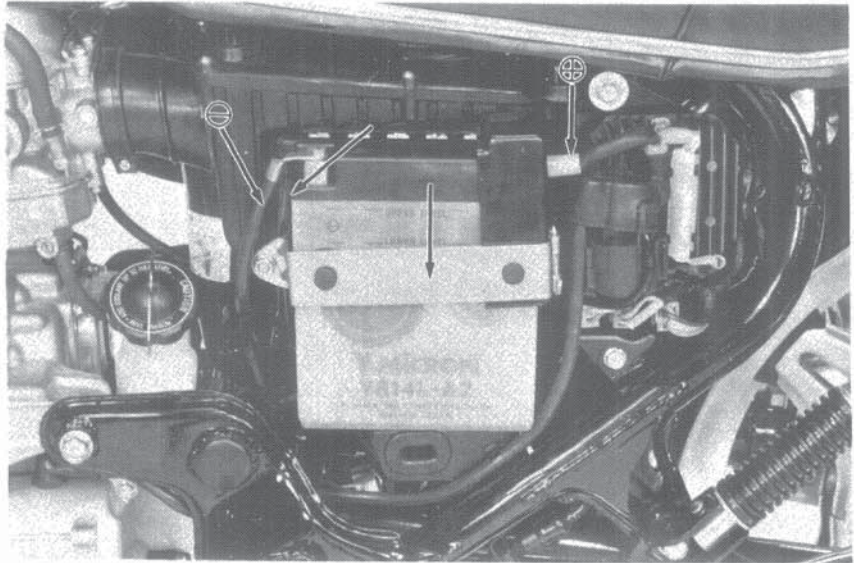

#### ● TESTING SPECIFIC GRAVITY

Test each cell by drawing electrolyte into the hydrometer.

SPECIFIC GRAVITY (20°C, 68°F)

Fully charged: 1.27–1.29

Undercharged: Below 1.26

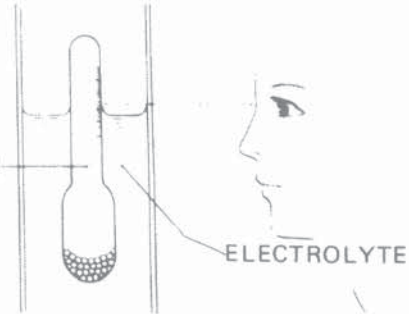

#### NOTE

- The battery must be recharged if the specific gravity is below 1.23.
- The specific gravity varies with the temperature as shown in the accompanying table.
- Replace the battery if sulfation is evident.
- The battery must be replaced if pastes have settled on the bottom of each cell.

#### WARNING

- *The battery electrolyte contains sulfuric acid. Protect your eyes, skin, and clothing.*
- *In case of contact, flush thoroughly with water and call a doctor if your eyes were exposed.*

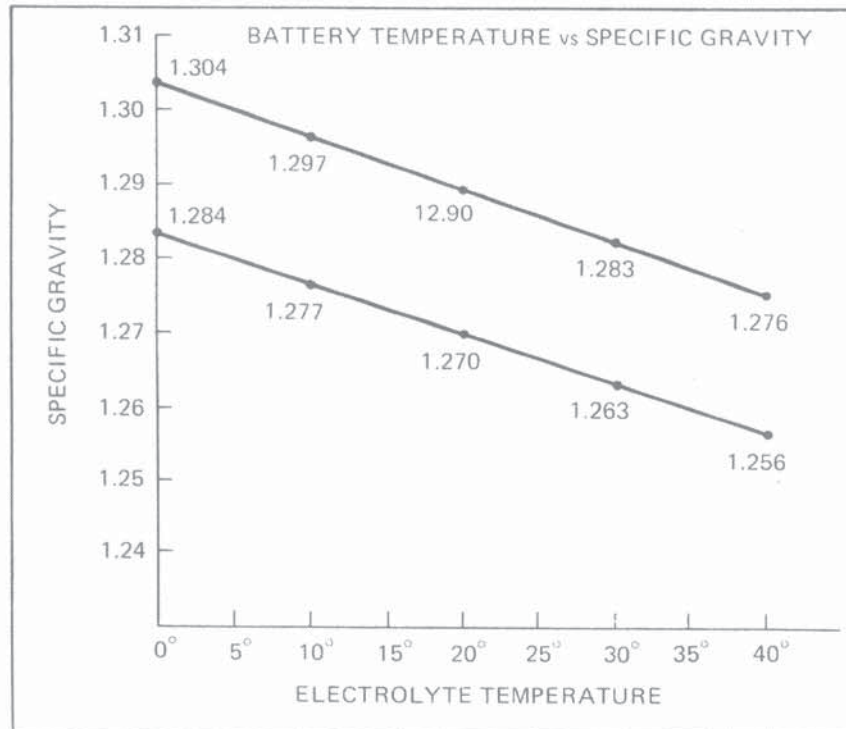

Specific gravity changes by 0.007 for every 10°C





● BATTERY CHARGING

Hookup instruction:

- Connect the charger positive (+) cable to the battery positive (+) terminal.
- Connect the charger negative (-) cable to the battery negative (-) terminal.

Charging current:

1.4 amperes maximum

Charging:

Charge the battery until specific gravity is 1.27 ~ 1.29 at 20°C (68°F)

**WARNING**

- Before charging a battery, remove the cap from each cell.
- Keep fire and sparks away from a charging battery.
- Turn power ON/OFF at the charger, not at the battery terminals.
- Discontinue charging if the electrolyte temperature exceeds 45°C (117°F).

**CAUTION**

Quick-charging should only be done in an emergency; slow-charging is preferred.

After installing the battery, apply an anti-corrosive coating to the terminals.

**CAUTION**

Route the breather tube as shown on the battery caution label.

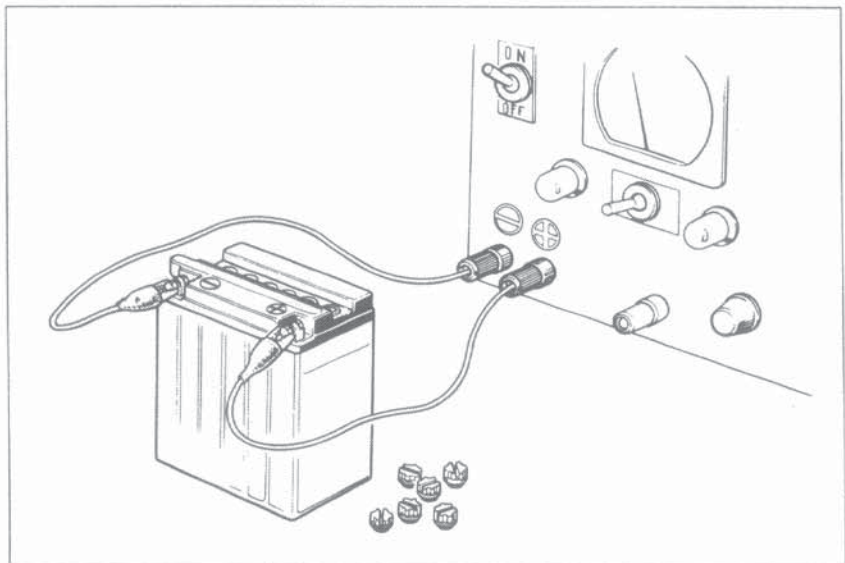

**CAUTION**

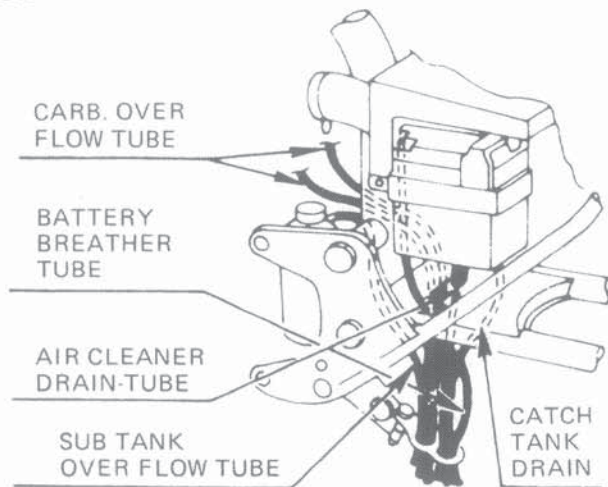

**CHARGING SYSTEM**

● CHARGING OUTPUT TEST

Warm up the engine before taking readings. Disconnect the black lead from the regulator/rectifier to bypass the voltage regulator. Connect a voltmeter and ammeter.

**NOTE**

Use a fully charged battery to check the charging system output.

**TECHNICAL DATA:**

MAIN SWITCH	LIGHTING SWITCH	CHARGING RPM	5,000 rpm
ON	ON (High beam)	1,100 rpm	(5 amperes minimum/ 14.5 volts)

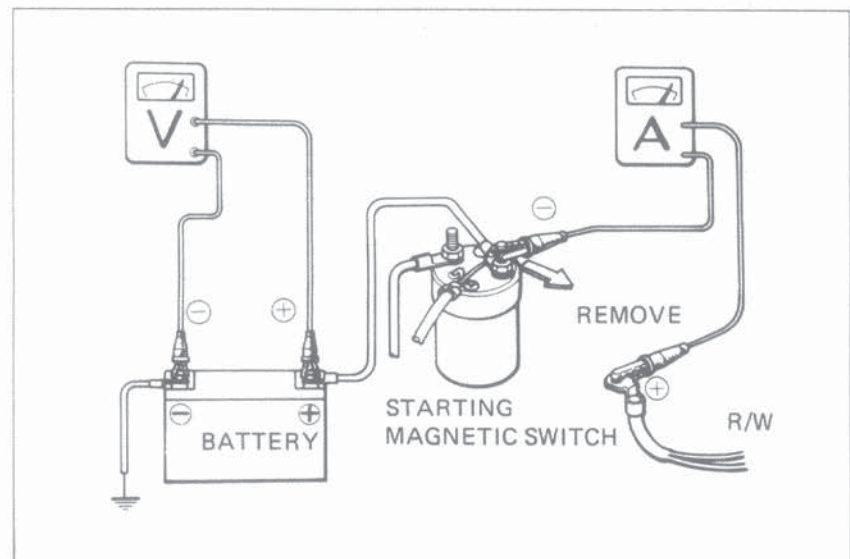



### • STATOR COIL CONTINUITY TEST

#### NOTE

It is not necessary to remove the stator to make this test.

Check the yellow leads to the AC generator stator for continuity with each other. Replace the stator if any yellow lead is not continuous with the others, or if any lead has continuity to ground.

REMOVAL (Page 8-3)

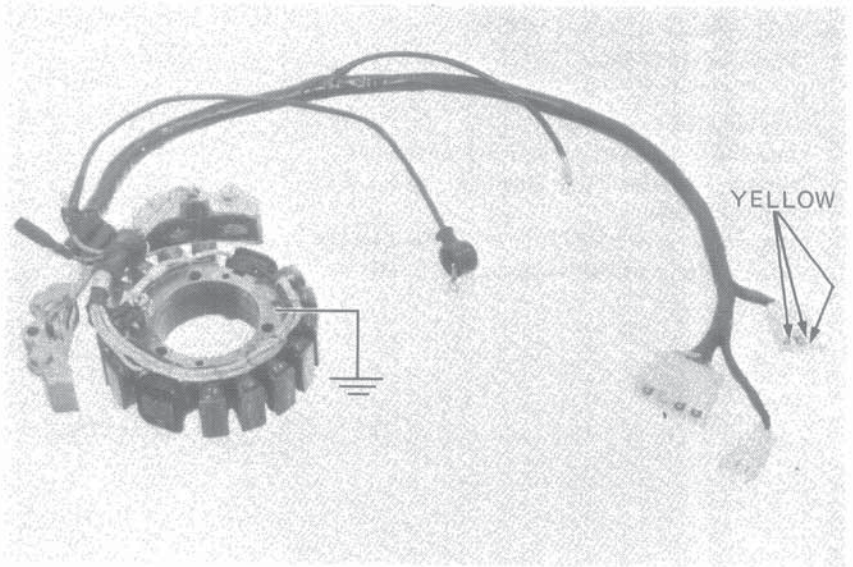

### • VOLTAGE REGULATOR/RECTIFIER TEST

Check the resistances between the leads with an ohmmeter.

#### WARNING

*Do not use a high voltage source such as insulation resistance tester since it may damage the rectifier and give you a shock.*

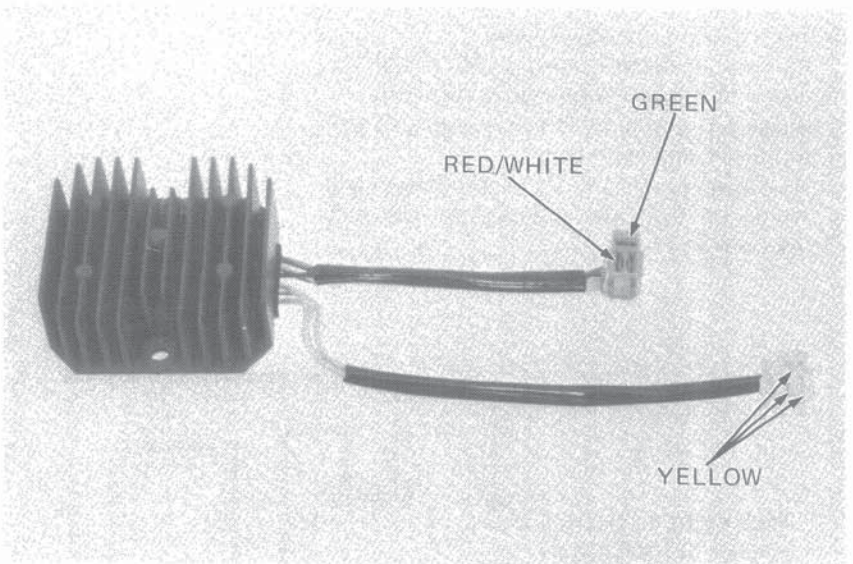

#### NORMAL DIRECTION: CONTINUITY

	⊕ probe	⊖ probe
I	YELLOW	GREEN
II	RED/WHITE	YELLOW

#### REVERSE DIRECTION: NO CONTINUITY

	⊕ probe	⊖ probe
I	GREEN	YELLOW
II	YELLOW	RED/WHITE

#### NOTE

The test results shown are for a positive ground ohmmeter and the opposite results will be obtained when a negative ground ohmmeter is used.

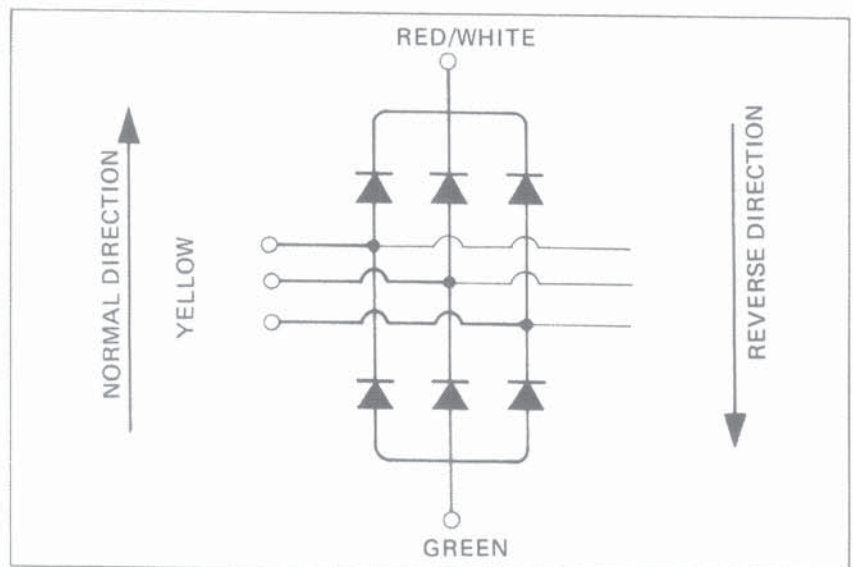





**BATTERY/CHARGING SYSTEM**

• **VOLTAGE REGULATOR PERFORMANCE TEST**

- a. Testing with a voltmeter  
Connect a voltmeter across the battery.  
Check regulator performance with the engine running.  
Regulator must divert current to ground when battery voltage reaches 14.0 ~ 15.0 V.

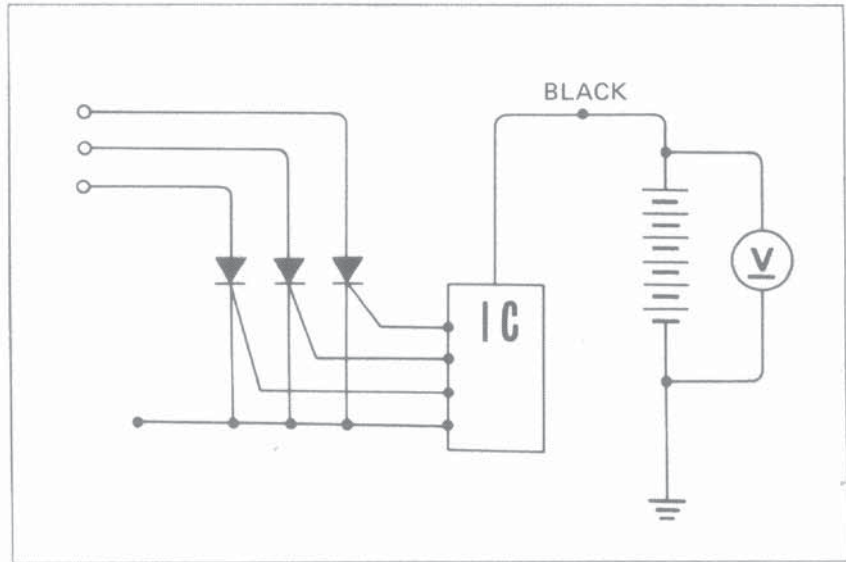

- b. Testing with a variable resistor  
Connect a variable resistor (0 ~ 100 Ω) across the battery with a 50 Ω resistance.  
Check for continuity between green and each of three yellow terminals.  
Test lamp must come on when voltage reads 14 to 15 V on the voltmeter by adjusting the variable resistor.

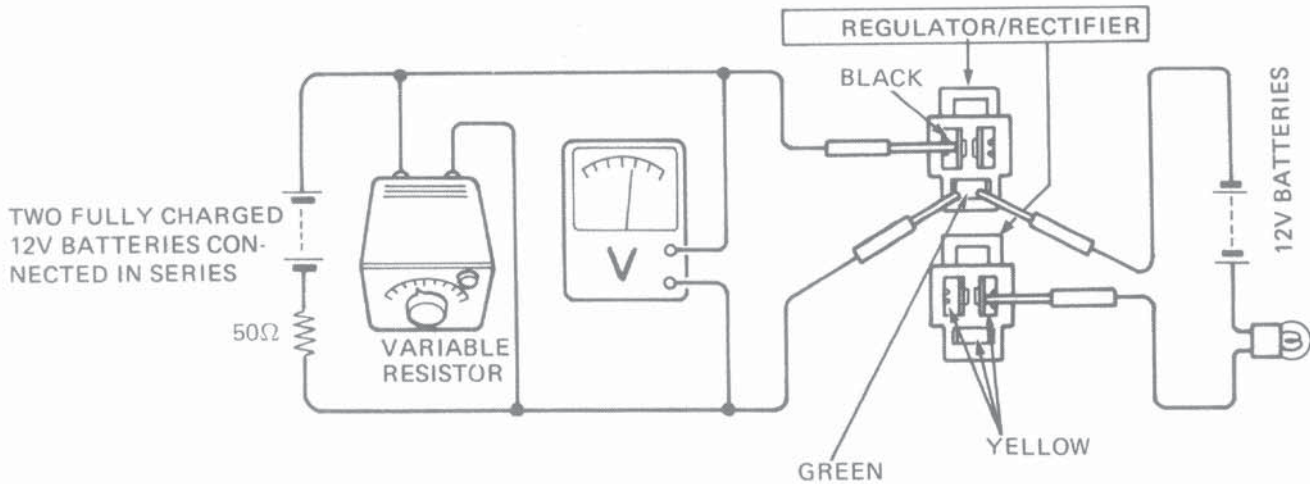

**A.C. GENERATOR REMOVAL/  
INSTALLATION**

Removal and installation procedure Section 8.



# 17. IGNITION SYSTEM

SERVICE INFORMATION	17-1
TROUBLESHOOTING	17-2
SPARK PLUG	17-3
IGNITION COIL	17-3
C.D.I. UNIT	17-4
A.C. GENERATOR	17-5
ADVANCE PULSER	17-6
IGNITION TIMING CHECK	17-6

## SERVICE INFORMATION

### • WORKING PRACTICE

Ignition timing cannot be adjusted since the C.D.I. (Capacitive Discharge Ignition) unit is non-adjustable. If ignition timing is incorrect, check the C.D.I. unit and AC generator and replace any defective part.

### • SPECIFICATIONS

Spark plug		X24ES-U (ND), D8EA (NGK)
Spark plug gap		0.6-0.7 mm (0.024-0.028 in.)
Ignition timing	Initial	15°
	Full advance	37°
	Engine speed (initial)	1,750-2,250 rpm
	Engine speed (full advance)	5,500-6,000 rpm
Ignition coil	3-point spark test	6 mm (0.24 in.) minimum





**IGNITION SYSTEM**

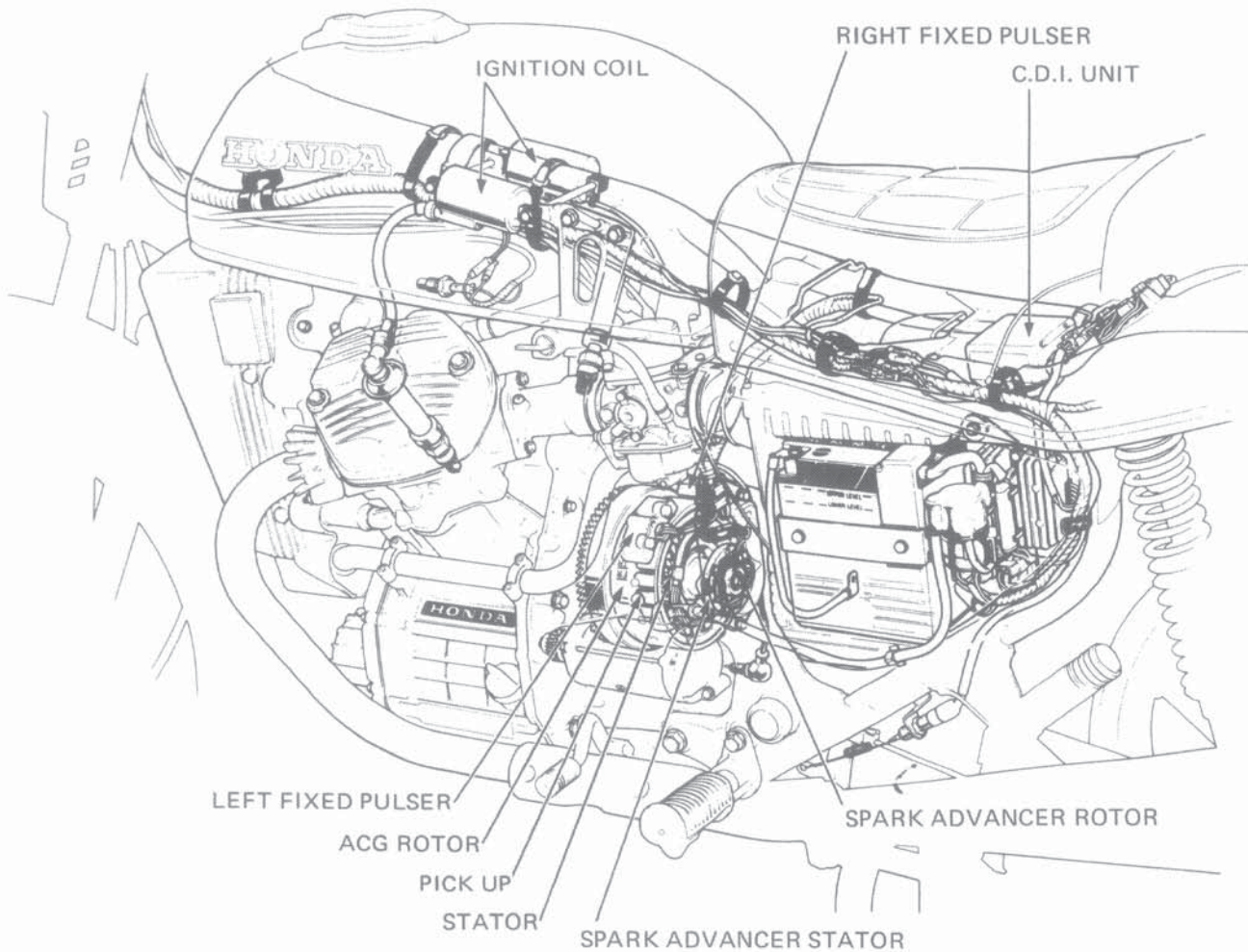

**TROUBLESHOOTING**

**Engine Cranks but Will Not Start:**

1. Engine stop switch OFF
2. No spark at plugs
3. Faulty C.D.I. unit
4. AC generator faulty

**No Spark at Plugs**

1. Engine stop switch OFF
2. Poor connection broken or shorted wires
  - Between AC generator and ignition coil
  - Between C.D.I. unit and engine stop switch
  - Between C.D.I. unit and ignition coil
  - Between C.D.I. unit and ignition switch
  - Between ignition coil and plug
3. Faulty ignition switch
4. Faulty ignition coil
5. C.D.I. Unit faulty
6. Faulty A.C. generator

**Engine Starts but Runs Poorly**

1. Ignition primary circuit
  - Faulty ignition coil
  - Loose or bare wire
  - Intermittent short-circuit in a switch
2. Secondary circuit
  - Faulty plug
  - Faulty high tension cord
3. Ignition timing
  - Faulty A.C. generator
  - Faulty C.D.I. unit

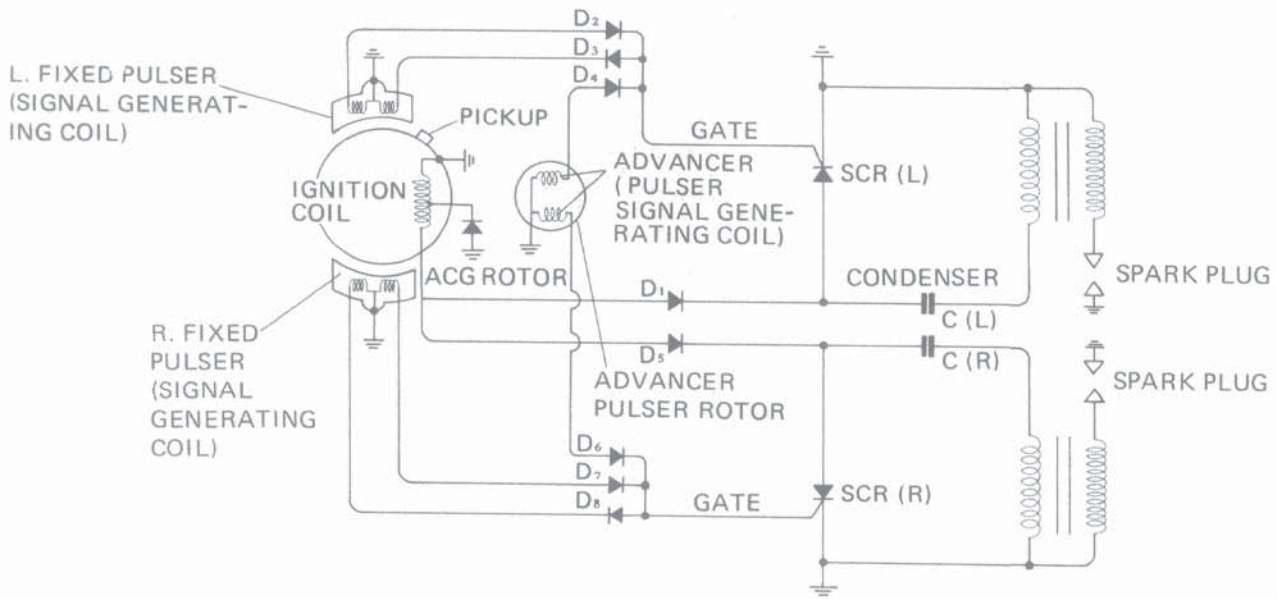

### SPARK PLUG

Spark plug gap inspection and adjustment procedure (Page 3-3).

### IGNITION COIL

#### • REMOVAL/INSTALLATION

Remove the fuel tank.  
Disconnect the wire leads.  
Remove the coil by removing the attaching bolts.

#### NOTE

Connect the right and left cables properly.

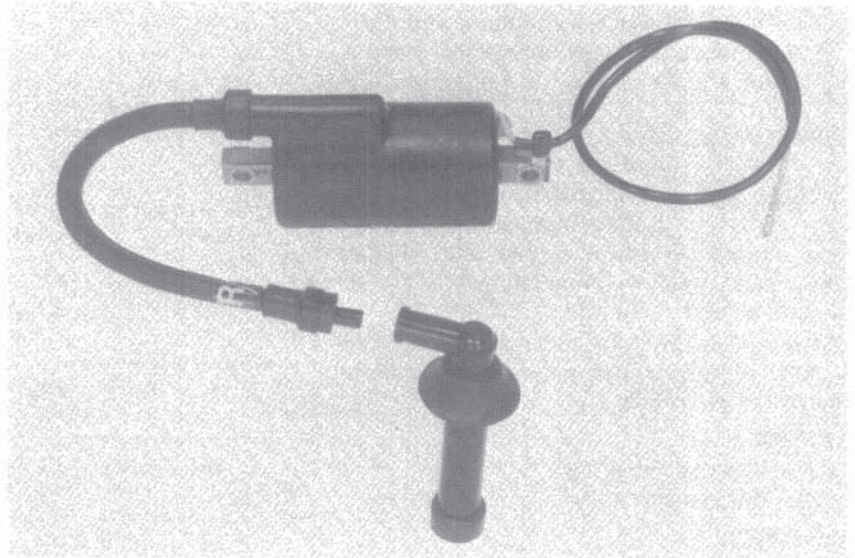

#### • PERFORMANCE TEST

Perform a 3-point spark test with a coil tester.

#### NOTE

Follow the instructions supplied with the coil tester.

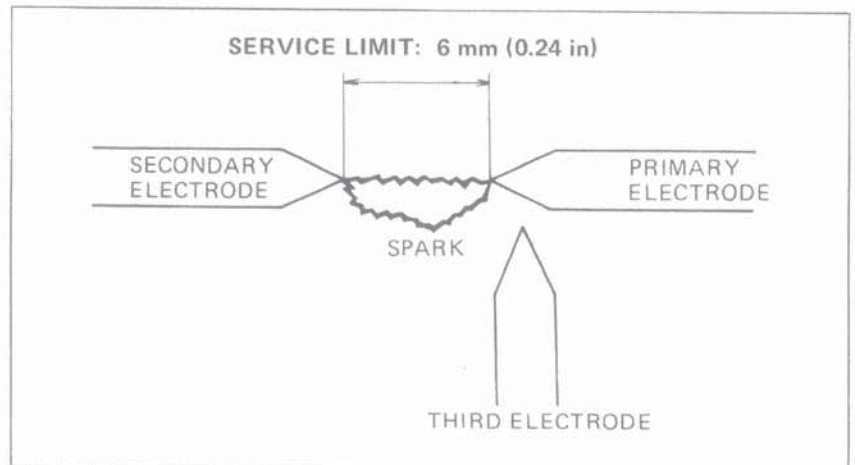





### C.D.I. UNIT

#### • INSPECTION

Disconnect wiring. Set the tester at  $xk\Omega$  or  $x100\Omega$  and check continuity of C.D.I. terminals. Replace the C.D.I. unit if the readings do not fall within the limits shown in the table.

#### NOTE

- The C.D.I. unit is fully transistorized. For accurate testing, it is necessary to use a specified electrical tester. Use of an improper tester or measurements in improper range may give false readings.
- Use SANWA ELECTRICAL TESTER (SP-10D) P/N 07308-0020000 or KOWA ELECTRICAL TESTER (TH-5H).
- Discharge the capacitor before testing.
- Needle swinging and going back to  $\infty$  in the table indicates that a capacitor is being charged with the tester. The tester needle will stay at infinity in subsequent tests unless the capacitor is discharged.

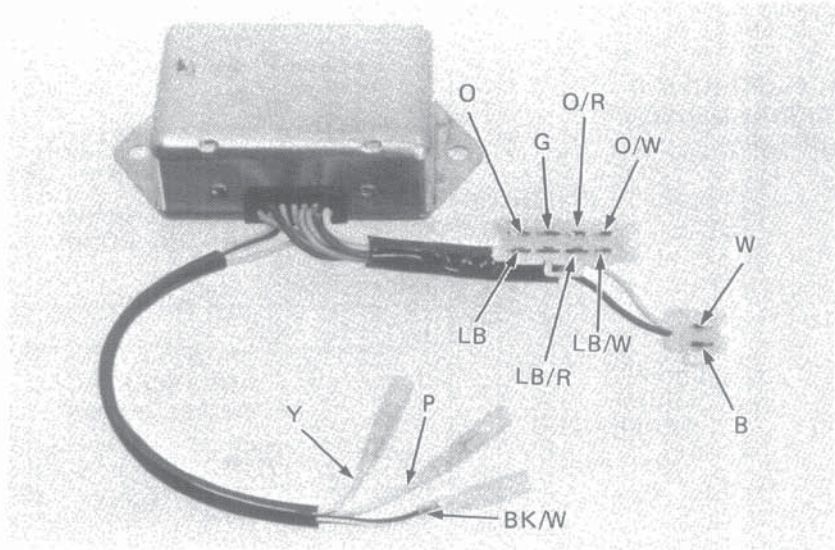

<Fig. 1>

- probe	W	B	LB	O	LB/R	O/R	G	LB/W	O/W	P	Y	BK/W
+ probe												
W		500 ~∞	10 ~ 20 20 ~ 60	10 ~ 20 20 ~ 60	500 ~∞	500 ~∞	3 ~ 8	10 ~ 20 20 ~ 60	10 ~ 20 20 ~ 60	500 ~∞	500 ~∞	500 ~∞
B	500 ~∞		500 ~∞	-	-	-	-	-	-	-	-	-
LB	500 ~∞	-		500 ~∞	-	-	-	-	-	-	-	-
O	500 ~∞	-	-		500 ~∞	-	-	-	-	-	-	-
LB/R	500 ~∞	500 ~∞	10 ~ 20 20 ~ 60	10 ~ 20 20 ~ 60		500 ~∞	3 ~ 8 5 ~ 20	10 ~ 20 20 ~ 100	10 ~ 20 20 ~ 100	500 ~∞	-	-
O/R	500 ~∞	500 ~∞	10 ~ 20 20 ~ 60	10 ~ 20 20 ~ 60	500 ~∞		3 ~ 8 5 ~ 20	10 ~ 20 20 ~ 100	10 ~ 20 20 ~ 100	500 ~∞	-	-
G	500 ~∞	500 ~∞	3 ~ 8 5 ~ 20	3 ~ 8 5 ~ 20	500 ~∞	500 ~∞		3 ~ 8 5 ~ 20	3 ~ 8 5 ~ 20	500 ~∞	-	-
LB/W	500 ~∞	-	-	-	-	-	-		500 ~∞	-	-	-
O/W	500 ~∞	-	-	-	-	-	-	-		500 ~∞	-	-
P	500 ~∞		-	-	500 ~∞	500 ~∞		-	-			
Y	500 ~∞		-	-	500 ~∞	500 ~∞		-	-	500 ~∞		
BK/W	500 ~∞	10 ~ 20 20 ~ 60	500 ~∞	-	-	-	-	-	-	-	-	

UPPER ROW: MEASURING RANGE (SANWA TESTER)  $xk\Omega$   
 LOWER ROW: MEASURING RANGE (KOWA TESTER)  $x100\Omega$

The resistances shown in the table indicate those to be read on the tester, not of specific circuits or parts.

The specifications in Fig. 1 are applicable to the C.D.I. unit (Galvanized on the cover) used on the following models;

<CX500>

F. No. ~CX500-2051739

F. No. CX500-21XXXXX

<CX500C>

F. No. PC01-20XXXXX

F. No. ~PC01-2111953

<CX500D>

F. No. PC01-40XXXXX

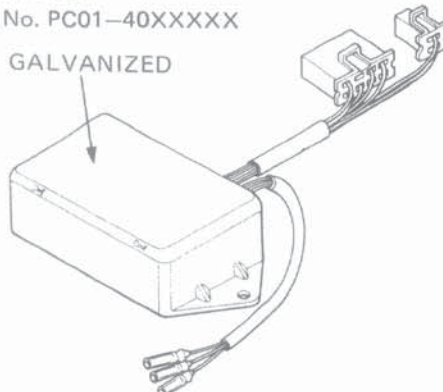





Specifications in Fig. 2 are applicable to the C.D.I. unit (Cover painted with black) used on following models;

<CX500>

F. No. CX500-2051740~

F. No. CX500-2200013~

<CX500C>

F. No. CX500C-2111954~

F. No. PC01-2114149~

<CX500D>

F. No. PC01-4100012~

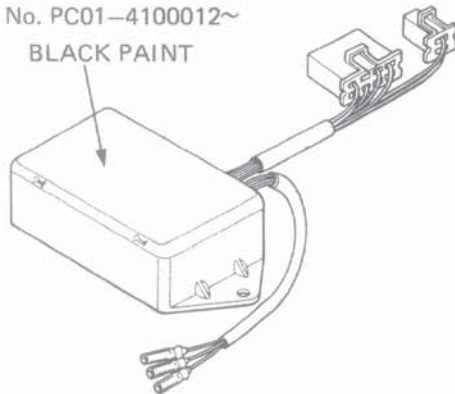

<Fig. 2>

Probe (-)	W	B	LB	O	LB/R	O/R	G	LB/W	O/W	P	Y	BK/W
Probe (+)												
W		500 ~	10~20 20~60	10~20 20~60	500 ~	500 ~	3~8 3~20	10~20 20~60	10~20 20~60	500 ~	500 ~	500 ~
B	500 ~		500 ~	500 ~	500 ~	500 ~	500 ~	500 ~	500 ~	500 ~	500 ~	500 ~
LB	500 ~	500 ~		500 ~	500 ~	500 ~	500 ~	500 ~	500 ~	500 ~	500 ~	500 ~
O	500 ~	500 ~	500 ~		500 ~	500 ~	500 ~	500 ~	500 ~	500 ~	500 ~	500 ~
LB/R	500 ~	500 ~	10~20 20~60	10~20 20~60		500 ~	3~8 5~20	10~20 20~100	10~20 20~100	500 ~	500 ~	500 ~
O/R	500 ~	500 ~	10~20 20~60	10~20 20~60	500 ~		3~8 5~20	10~20 20~100	10~20 20~100	500 ~	500 ~	500 ~
G	500 ~	500 ~	3~8 5~20	3~8 5~20	500 ~	500 ~		3~8 5~20	3~8 5~20	500 ~	500 ~	500 ~
LB/W	500 ~	500 ~	500 ~	500 ~	500 ~	500 ~	500 ~		500 ~	500 ~	500 ~	500 ~
O/W	500 ~	500 ~	500 ~	500 ~	500 ~	500 ~	500 ~	500 ~		500 ~	500 ~	500 ~
P	500 ~	∞	∞	∞	500 ~	500 ~	∞	∞	∞		∞	500 ~
Y	500 ~	∞	∞	∞	500 ~	500 ~	∞	∞	∞	500 ~		500 ~
BK/W	500 ~	20~100 100~500	500 ~	500 ~	500 ~	500 ~	500 ~	500 ~	500 ~	∞	∞	500 ~

### A.C. GENERATOR

#### • INSPECTION

Disconnect the stator wires at their connections.

Measure resistances between the terminals:

WHITE-BLUE: 77-95 Ohms

GREEN-WHITE: 387-473 Ohms  
(315-385 Ohms)

ORANGE-GREEN: 95-116 Ohms

LIGHT BLUE-GREEN: 95-116 Ohms

ORANGE/RED-GREEN: 81-99 Ohms

LIGHT BLUE/RED-GREEN: 81-99 Ohms

#### NOTE

- TESTER MEASURING RANGE:  $\times 10\Omega$
- Use the HONDA SERVICE TESTER (07308-0020000) to perform this test.
- The specifications in parentheses are applicable to the A.C. generator used on the following models;
  - <CX500>  
E. No. CX500E-2049947~  
E. No. CX500E-2200013~
  - <CX500C>  
E. No. PC01E-2002941~  
E. No. PC01E-2114151~
  - <CX500D>  
E. No. PC01E-4001273~

A.C. Generator removal and installation procedures (Section 8).

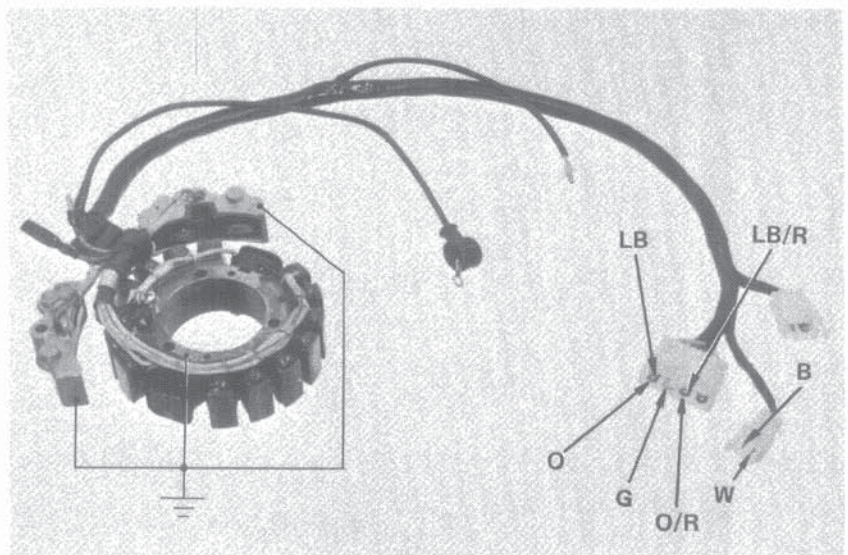





**IGNITION SYSTEM**

**ADVANCE PULSER**

● **INSPECTION**

Disconnect the advance pulser coupler.

Measure the resistance of stator coil.

ORANGE/WHITE-GREEN: 185-225Ω

LIGHT BLUE/WHITE-GREEN: 185-225Ω

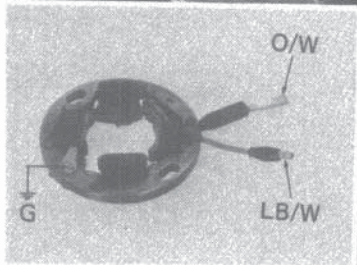
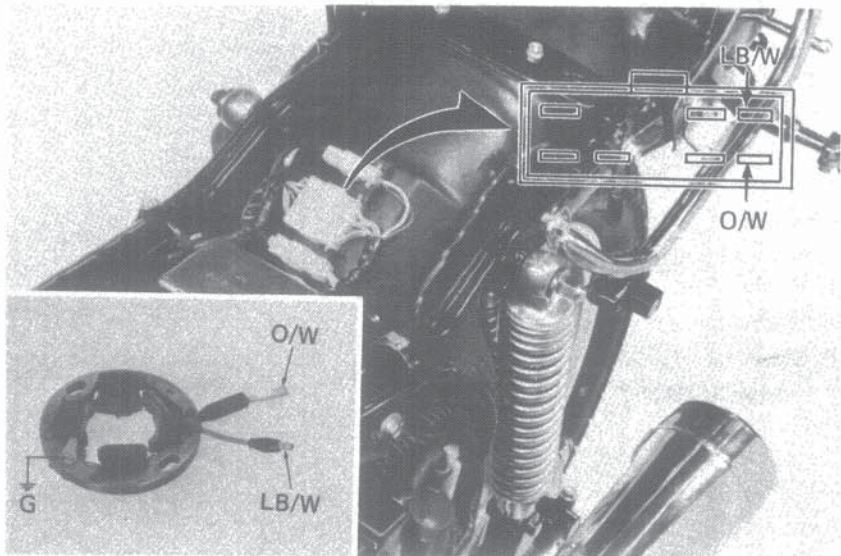

**IGNITION TIMING CHECK**

**NOTE**

The C.D.I. (capacitive discharge ignition) ignition timing is not adjustable. If the ignition timing is incorrect, check the C.D.I. unit and A.C. Generator.

Remove the timing hole inspection cap from the engine case rear cover.

Connect a stroboscopic timing light to the right cylinder. Connect a tachometer.

Check that the flywheel "FR" mark and pulser index mark align at idle.

Check that the index mark is between the advance marks at 5,500-6,000 rpm.

Repeat for the left cylinder using the "FL" reference mark.

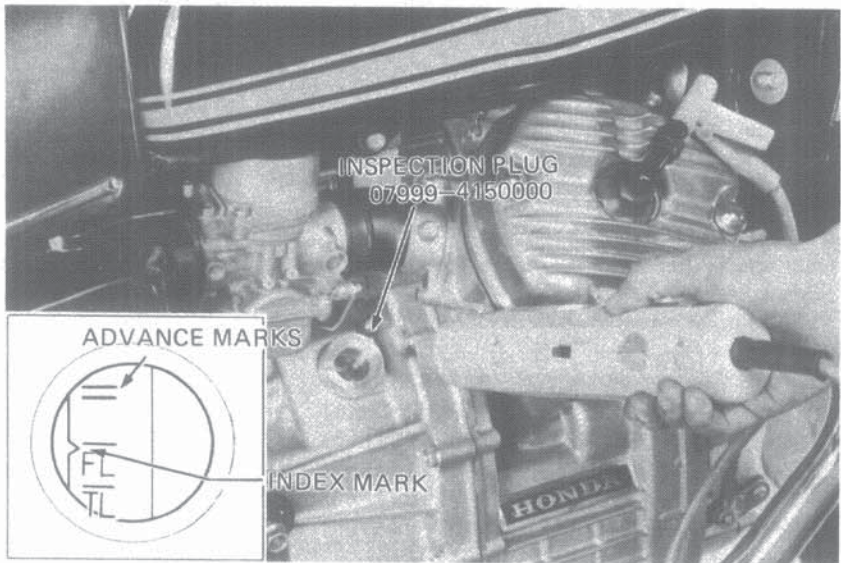



# 18. STARTER MOTOR

SERVICE INFORMATION	18-1
TROUBLESHOOTING	18-2
STARTER MOTOR	18-3
MAGNETIC SWITCH	18-5
DIODE	18-5
NEUTRAL SWITCH	18-5 (8-3)
STARTER CLUTCH	18-5 (8-5)

## SERVICE INFORMATION

### • WORKING PRACTICE

The starter motor can be removed with the engine in the frame. Starter clutch repairs (Page 8-3).

### • SPECIFICATIONS

		STANDARD	SERVICE LIMIT
Starter motor	Brush spring tension	0.495-0.605 kg	400 g
	Brush length	11.0-12.5 mm (0.43-0.49 in.)	5.5 mm (0.21 in.)

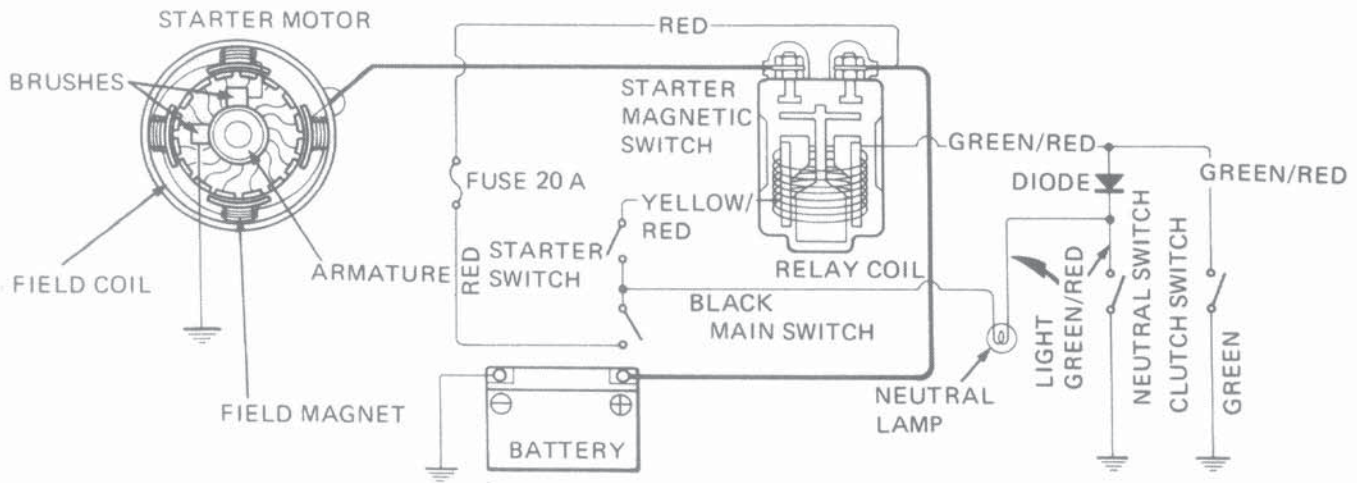





## **TROUBLESHOOTING**

### **Starter Motor Will Not Turn:**

1. Dead battery
2. Faulty ignition switch
3. Faulty start switch
4. Faulty neutral switch
5. Faulty starter magnetic switch
6. Loose or disconnected wire or cable
7. Neutral diode open
8. Faulty clutch switch

### **Starter Motor Turns Engine Slowly:**

1. Low battery
2. Excessive resistance in circuit
3. Binding in starter motor

### **Starter Motor Turns, But Engine Does Not Turn:**

1. Faulty starter clutch
2. Faulty starter motor gears
3. Faulty starter motor or idle gear

### **Starter Motor and Engine Turn, But Engine**

#### **Does Not Start:**

1. Faulty ignition system
2. Engine problems
3. Faulty engine stop switch



## STARTER MOTOR

### • REMOVAL

#### **WARNING**

*With the ignition switch OFF, remove the negative cable at the battery before servicing the starter motor.*

Remove the starter mounting bolts and pull the motor out of the engine case. Disconnect the starter cable.

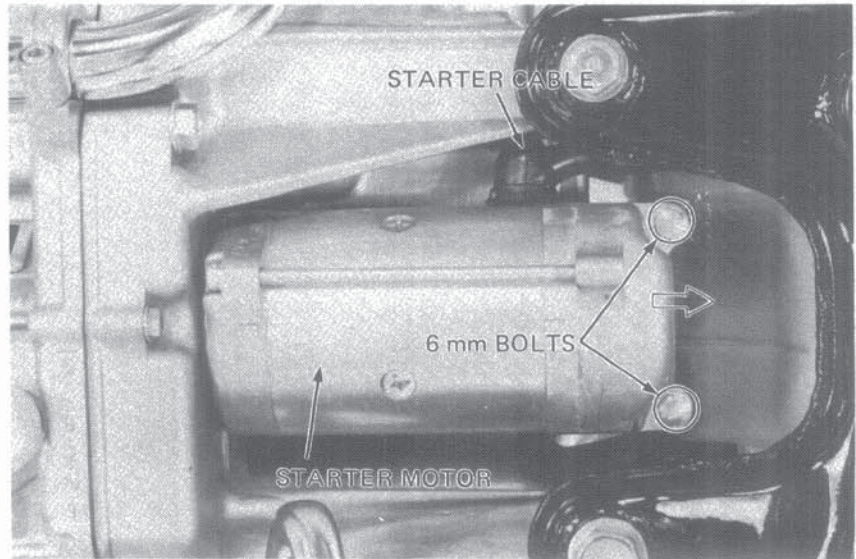

### • BRUSH INSPECTION

Remove the starter motor case screws. Inspect the brushes and measure brush length. Measure brush spring tension with a spring scale.

#### **SERVICE LIMITS:**

Brush length: 5.5 mm (0.21 in.)

Brush spring tension: 400 g

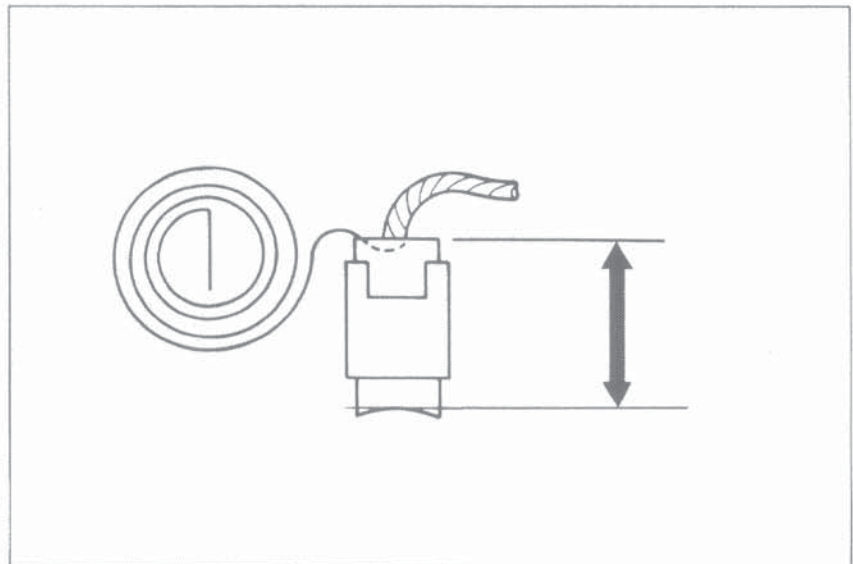

### • COMMUTATOR INSPECTION

Remove the case.

#### **NOTE**

Record the location and number of the thrust washers.

Inspect the commutator bars for discoloration.

Bars discolored in pairs indicate grounded armature coils.

#### **NOTE**

Do not use emery or sand paper on the commutator.

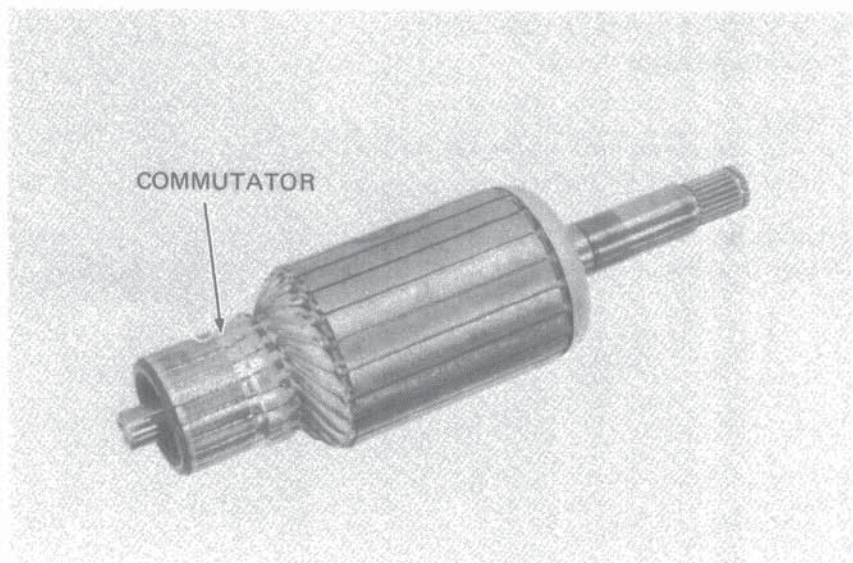





**STARTER MOTOR**

Check for continuity between pairs of commutator bars, and also between commutator bars and armature shaft.

Replace starter motor if armature coils are open, or shorted to armature shaft.

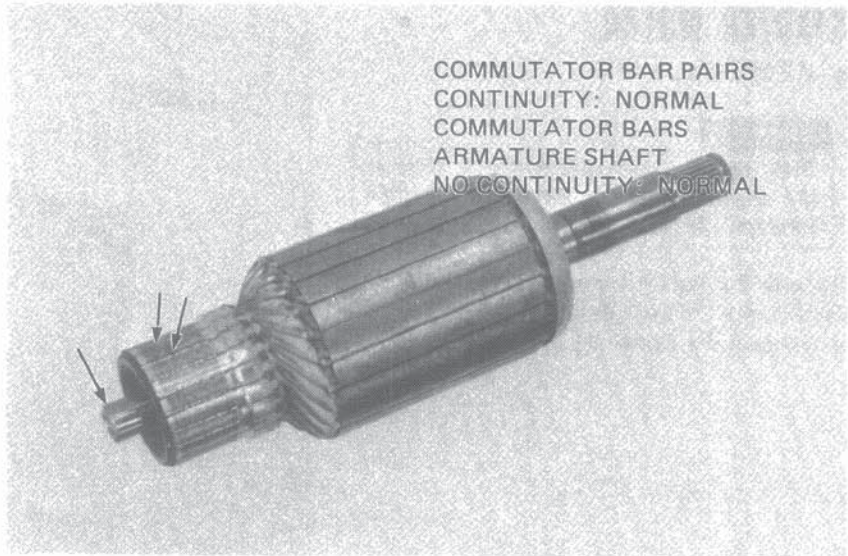

COMMUTATOR BAR PAIRS  
CONTINUITY: NORMAL  
COMMUTATOR BARS  
ARMATURE SHAFT  
NO CONTINUITY: NORMAL

**• FIELD COIL INSPECTION**

Check for continuity from the cable terminal to the motor case and from the cable terminal to the brush wire.

Replace the starter motor if the field coil is not continuous or if it is shorted to the motor case.

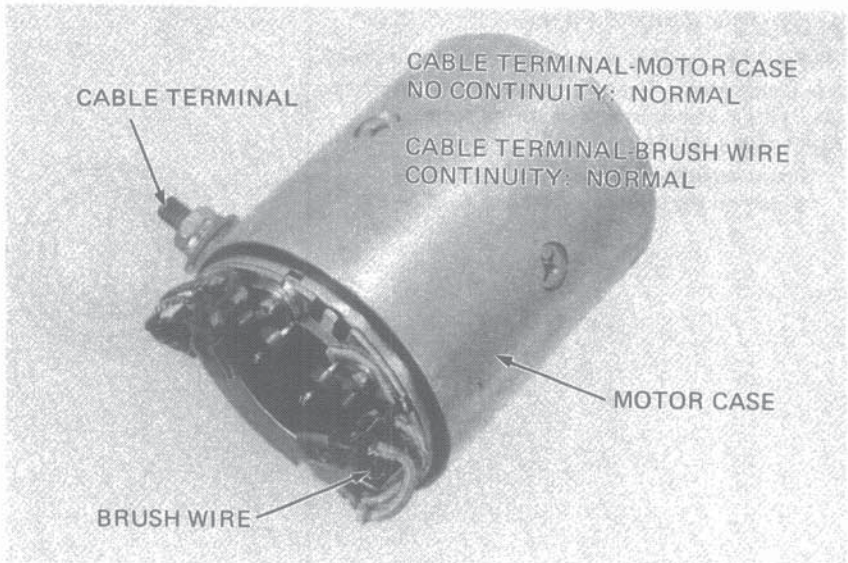

CABLE TERMINAL

CABLE TERMINAL-MOTOR CASE  
NO CONTINUITY: NORMAL

CABLE TERMINAL-BRUSH WIRE  
CONTINUITY: NORMAL

MOTOR CASE

BRUSH WIRE

**• ASSEMBLY/INSTALLATION**

Assemble the starter motor.

**NOTE**

Align the punch mark on the case to the punch mark on the cover.

Connect the starter motor cable.  
Install the starter motor on the engine.

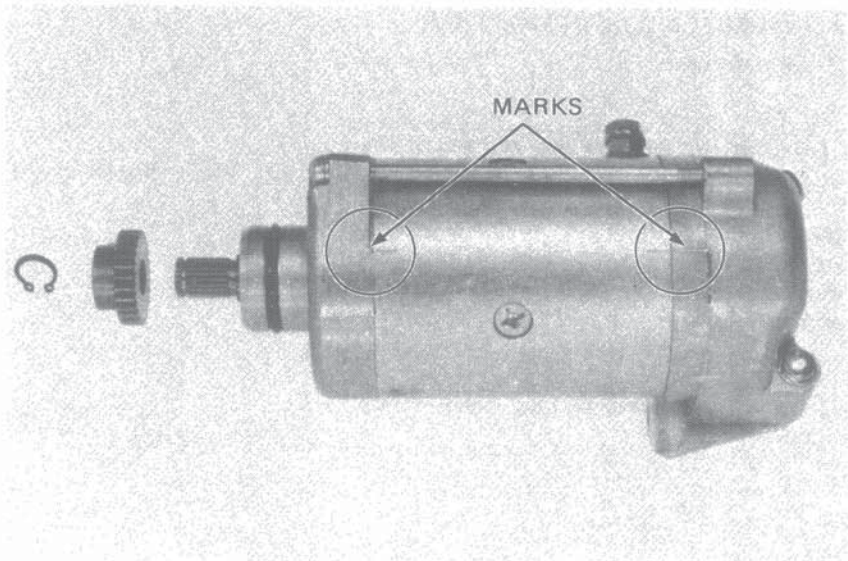

MARKS



### MAGNETIC SWITCH

• INSPECTION

To test if the switch primary coil is normal, depress the switch button. The coil is normal if the switch clicks into position.

Connect an ohmmeter to the switch terminals. Connect a 12 V battery to the switch cable terminals.

The switch is normal if there is continuity.

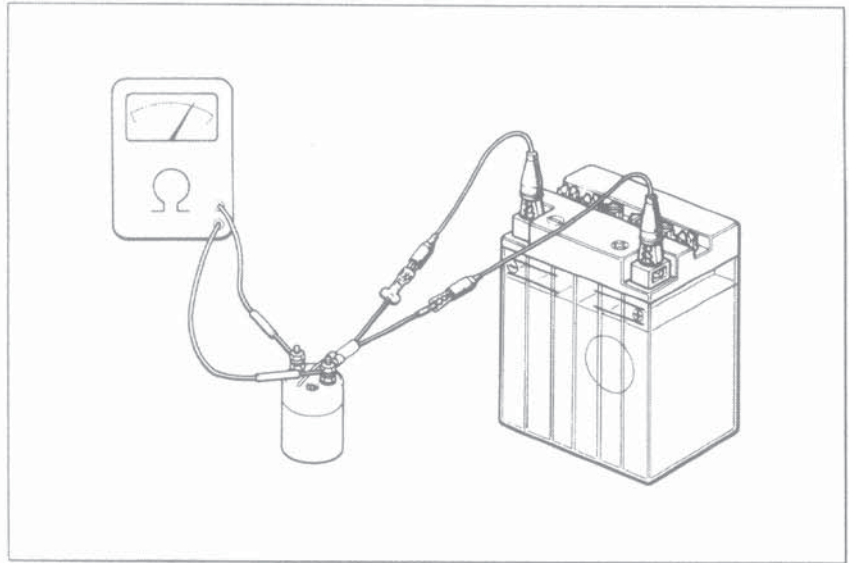

### DIODE

• INSPECTION

Remove the fuse cover.

Connect an ohmmeter to the diode leads.

**NORMAL DIRECTION: CONTINUITY**

⊕ probe : Light green/Red

⊖ probe : Green/Red

**REVERSE DIRECTION: NO CONTINUITY**

⊕ probe : Green/Red

⊖ probe : Light green/Red

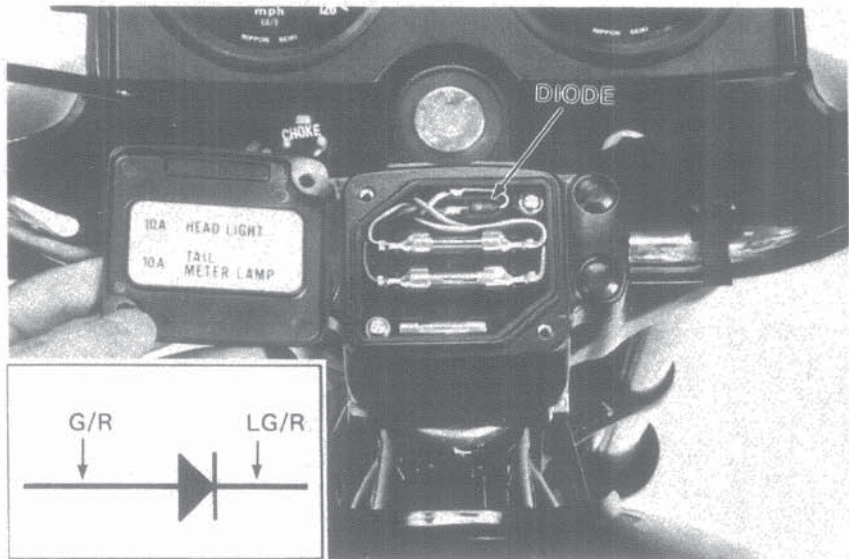

### NEUTRAL SWITCH

• INSPECTION (Page 8-3)

### STARTER CLUTCH

• REMOVAL (Page 8-5)





**WATER COOLED  
V-TWIN ENGINE**

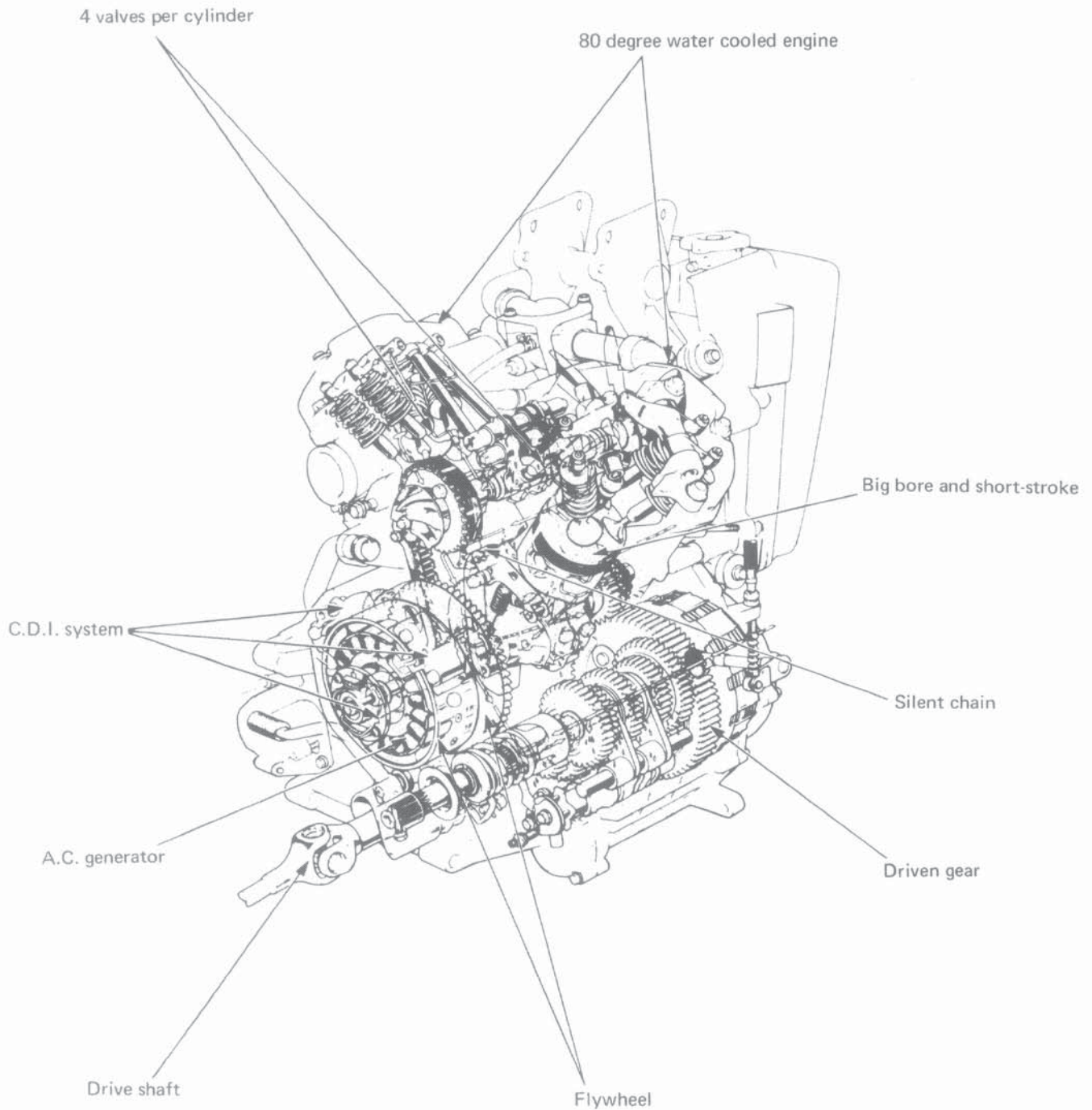



## COOLING SYSTEM

The cooling system consists of the radiator, reserve tank, thermostat, fan, water pump and water jackets that surround the cylinders and cylinder heads. The water pump is driven by the camshaft and draws cool water from the bottom of the radiator and pumps it through the water passage at the rear of the engine case into the water jacket of each cylinder. The coolant circulates around the cylinder bores and is directed upward into the cylinder heads where it cools the combustion chambers, valves, and valve seats. After cooling the cylinder heads, the coolant flows through the thermostat, if it is open, into the top of the radiator. In the radiator, the temperature of the coolant is reduced as it dissipates heat to the fan's air stream.

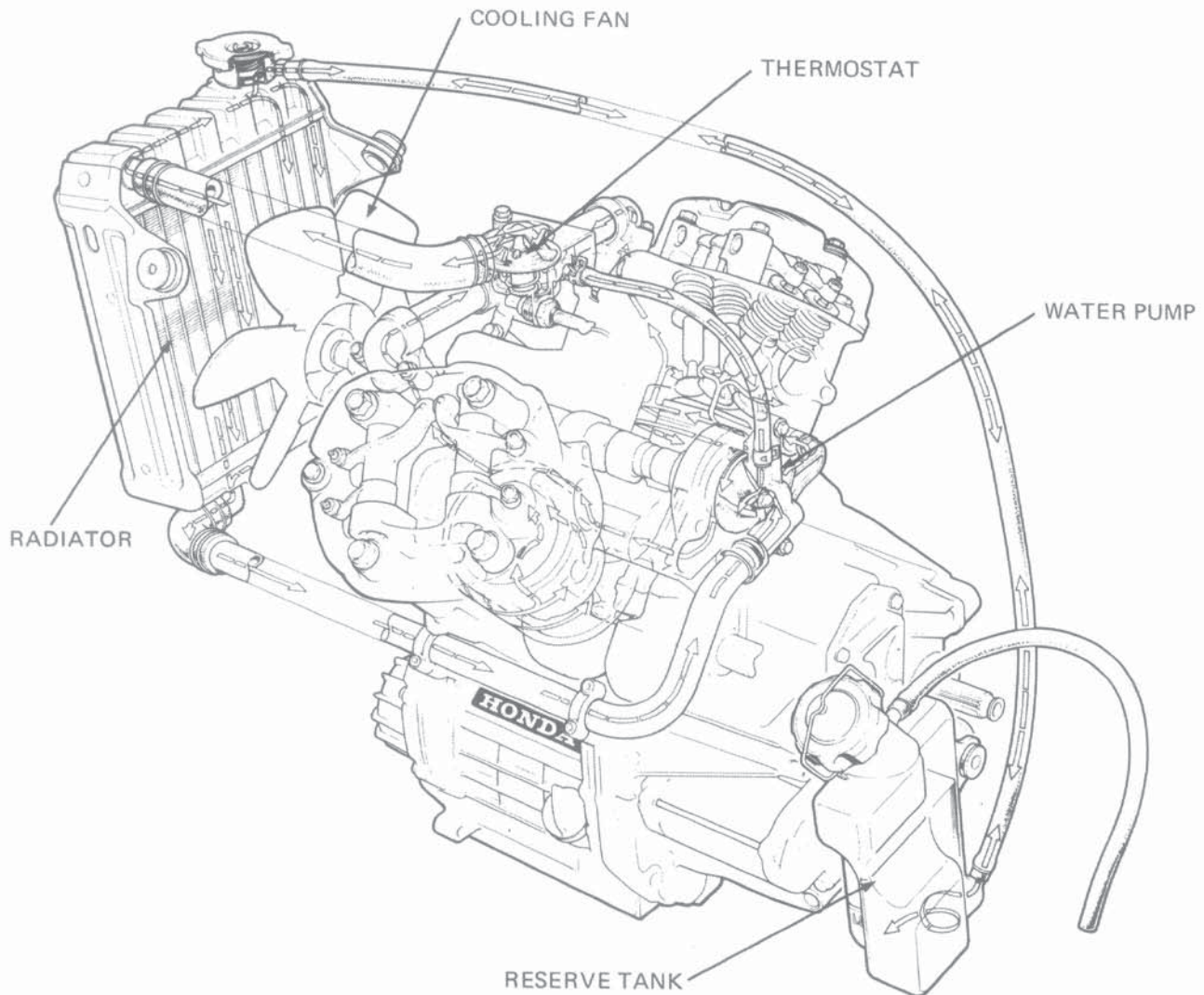

### • COOLANT FLOW

- When the engine is cold, the thermostat bellow contracts and closes the valve. This causes the coolant to circulate only in the engine water jackets. Only a small amount of coolant is returned through the by-pass hose into the radiator, causing the engine to warm up quickly.
- As the coolant warms, the bellow expands and the valve opens. This allows the coolant to flow to the radiator where it is maintained at the desired operating temperature.
- The radiator cap incorporates two valves, the relief valve and vacuum valve. The valve allows air and vapor or coolant to escape into the reserve tank if pressure exceeds that for which the system is designed, thereby maintaining a safe pressure in the system. The vacuum valve prevents formation of vacuum in the system when the engine begins to cool after it has been shut off. A pressure drop in the radiator causes the valve to open, allowing coolant from the reserve tank into the radiator. The design prevents loss of coolant by evaporation except that through the breather in the reserve tank and eliminates frequent refilling of the system.





## VALVE TRAIN

### • PUSH ROD OPERATED 4 VALVE DESIGN

The engine is a V-2, 4-valve, dual rocker arm, OHV design. In the V-2 engine, the cylinders are arranged in two banks of one cylinder each, with the two banks set at 44 degrees to each other for rigid construction. Motion is transmitted from a single camshaft through four push rods to the rocker arms. A durable silent chain drives the camshaft. The rocker arm wave washers contribute to smooth quiet operation.

Four valves per cylinder, high compression ratio, short stroke crankshaft and other unique design features enable the CX500 to out perform other motorcycles of comparable size.

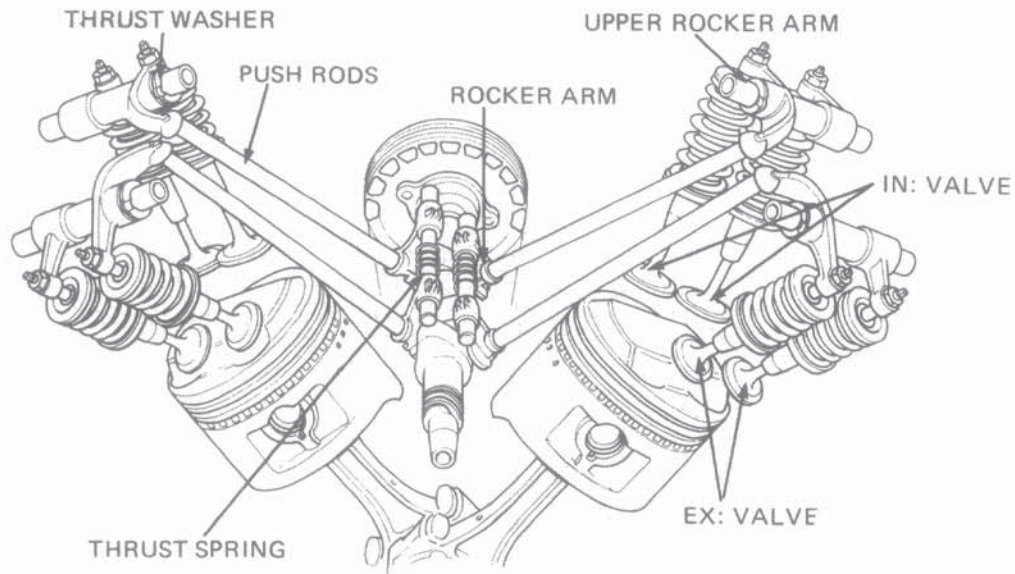

### • TWISTED CYLINDER HEAD

The cylinder heads are twisted at 44° to each other. This provides fuel-air passages that are short and practically straight from the carburetors to the exhaust pipes to ensure effective breathing.

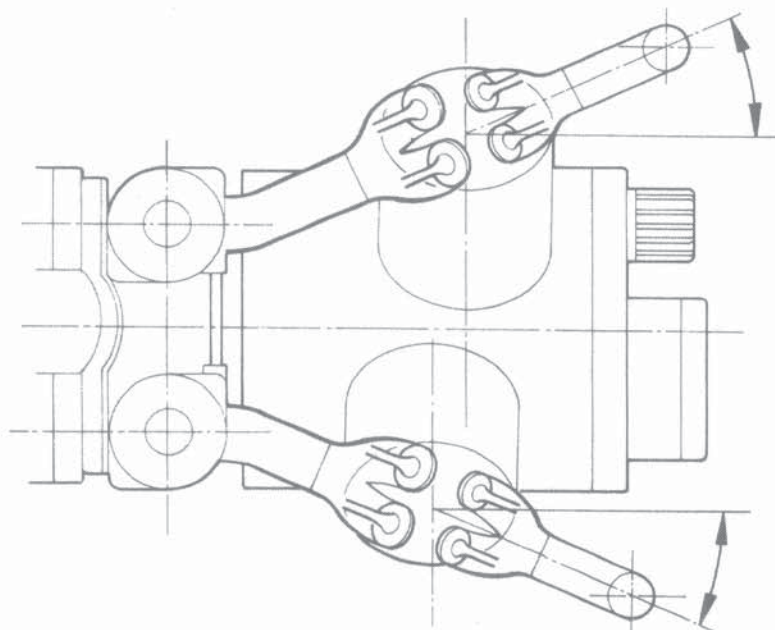



● **SHAFT DRIVE**

The power transmitting system uses a shaft drive in that power from the engine is transmitted by way of:

Final shaft — Universal joint — Propeller shaft — Propeller shaft joint — Pinion gear — Ring gear — Driven flange — Rear wheel.  
The pinion gear uses spherical splines to allow relative movement between the propeller shaft and this gear when the rear wheel moves up and down. The final gear case is filled with hypoid gear oil and is equipped with a breather. The pinion gear bearing retainer is packed with special grease.

● **TUBELESS TIRE**

The front and rear wheels incorporate a tubeless tire. It will carry nails and other puncturing objects for a considerable mileage without sudden puncture or blowout, thus providing added safety. Since the tubeless tire has no inner tube, heat caused by tire flexing is radiated to the air through the rim more effectively.

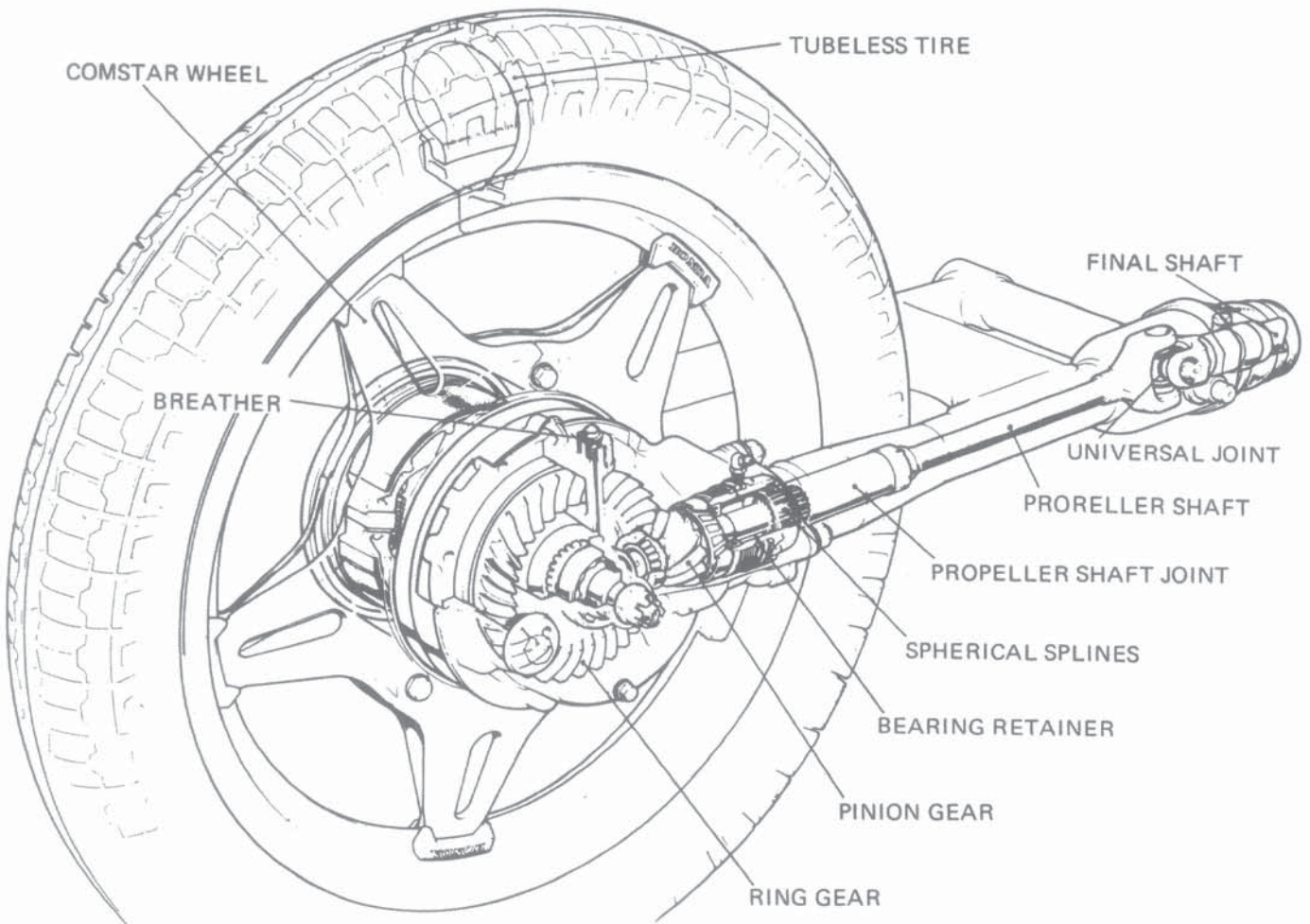





## C.D.I. SYSTEM

The C.D.I. system is designed to take advantage of the short-stroke, 4-valve engine. The term "C.D.I." stands for Capacitive Discharge Ignition.

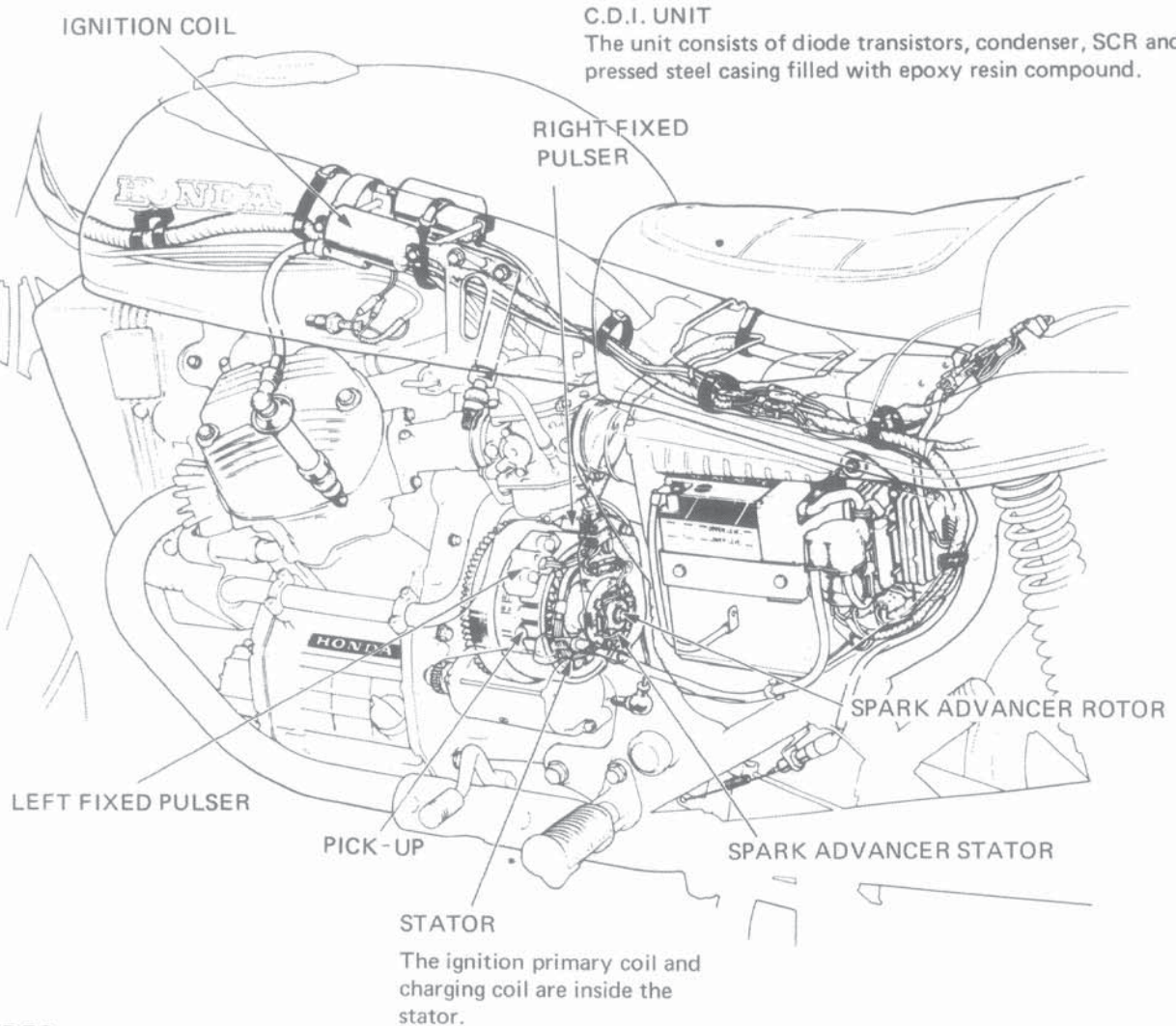

### • FEATURES

- There are no contact points to require attention.
- C.D.I. can develop more voltage potential at the spark plugs than conventional systems and is more resistant to spark plug fouling.
- Working on AC, the secondary voltage is more stable, regardless of battery condition.
- The timing advance will not be subject to errors and is virtually free from wear.
- The overall design eliminates initial and periodic adjustments and maintenance services.



• C.D.I. UNIT (CAPACITIVE DISCHARGE IGNITION)

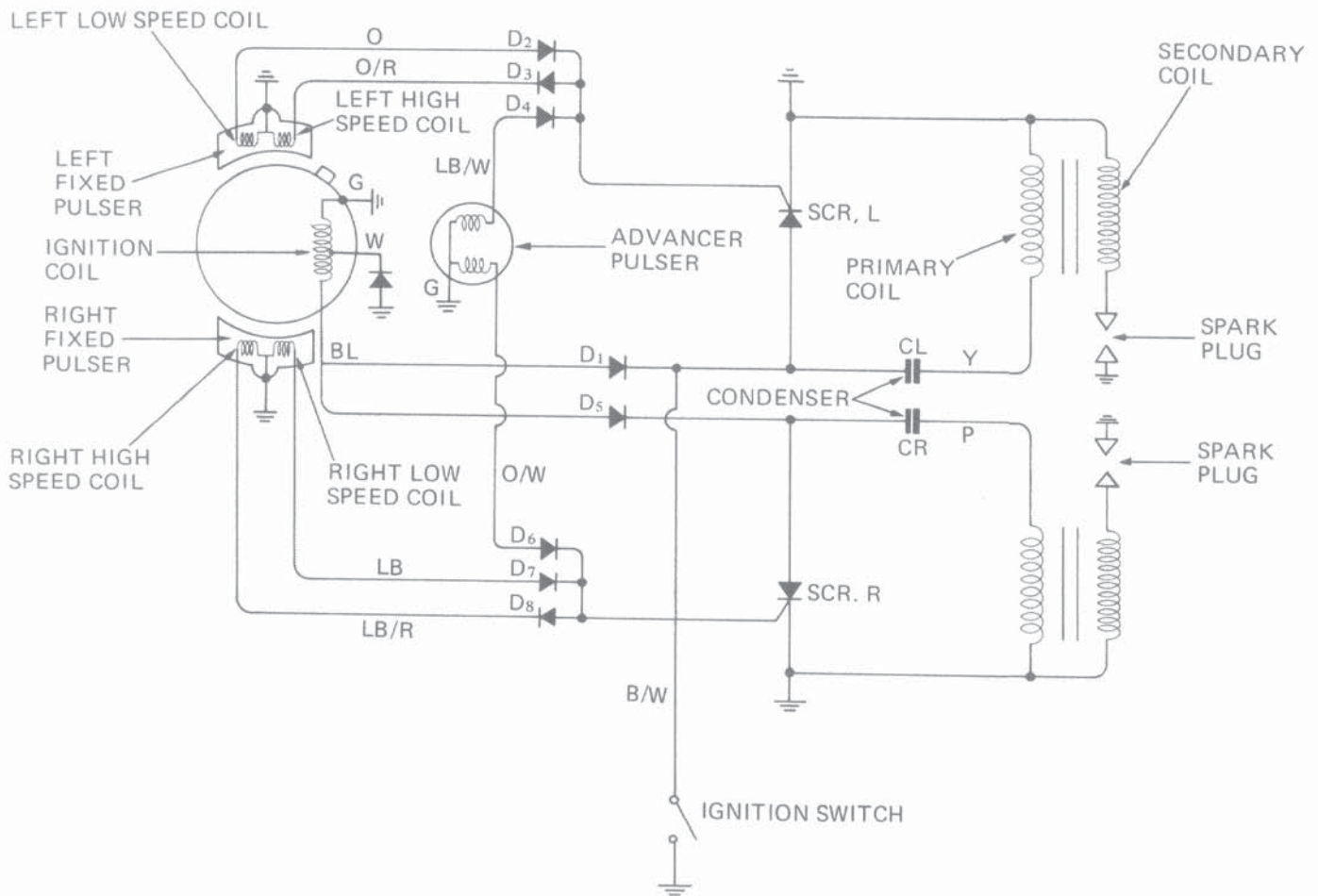

- As the AC generator rotor turns, current is induced in the AC generator (AC generating coil). This current is rectified as it passes through the diode D1 and is stored in the condenser CL. During this process, the SCR, L is kept OFF.
- An electric pulse is generated by the left fixed pulser when the pick up reaches the point where ignition must start. This is due to changes in the flux. The pulse is rectified by diode D2 and is applied to SCR, L gate. As this happens, SCR, L turns ON which in turn discharges the energy stored in the condenser through the primary coil. Sufficient potential is then developed at the spark plug to ignite the air-fuel mixture in the combustion chamber.
- Same sequence of events takes place for the right cylinder 280 degrees after ignition takes place in the left cylinder, in relation to the crankshaft rotation.





**TECHNICAL FEATURES**

- To advance timing, the signal from the fixed pulser is replaced by the output signal from the spark advancer pulser. The output signal applies to SCR, L gate through the diode D4 and fires the spark plug, performing the same function as the conventional system. The faster the engine speed, the faster the SCR, L is triggered to advance the timing.

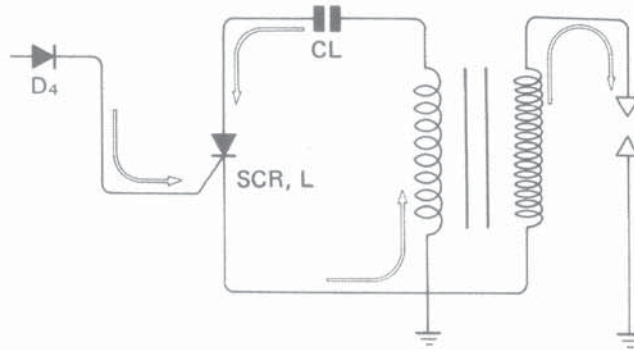

- The negative pulse from the fixed pulser balances the positive pulse from the spark advance pulser when the maximum advance is reached. This limits timing advance.

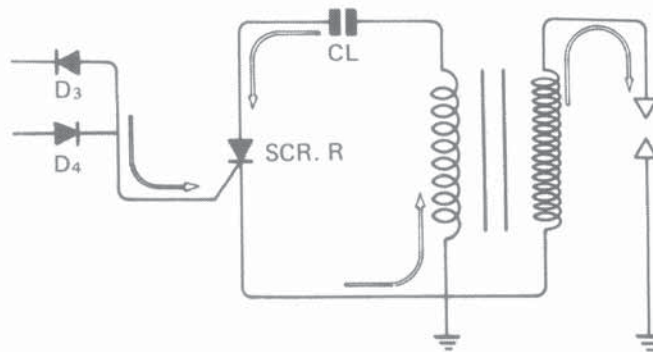

**• ADVANCER OPERATION**

In C.D.I. ignition, timing advance depends on the build-up time of voltage on the advance pulser, which becomes faster as engine speed increases. The SCR L acts like a switching device, but there is a definite voltage at which it triggers. The overall operation of the C.D.I. system stems from these two facts. The faster the voltage build-up, the earlier the SCR is triggered, allowing the system to perform the same function as the conventional system. The fixed pulser controls until the advancer pulser comes into operation.

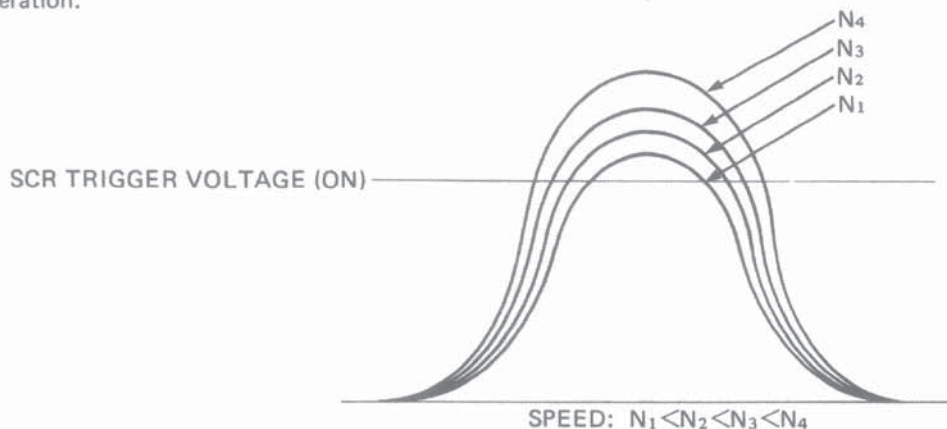



- PULSER WAVE FORMS AND SCR TRIGGER VOLTAGE BEFORE ADVANCE

Before advance starts, only the signal from the fixed pulser is applied to SCR gate through the diode D3.

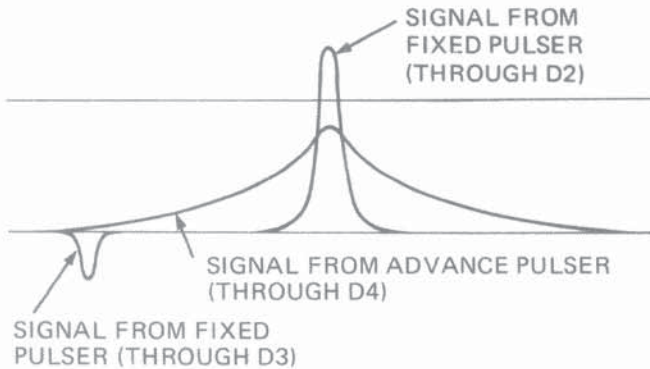

- PULSER WAVE FORMS WHEN ADVANCE STARTS

The voltage of the advance pulser rises to SCR trigger voltage faster than that of the fixed pulser. If there is an increase in engine speed, there will be a corresponding advance in timing.

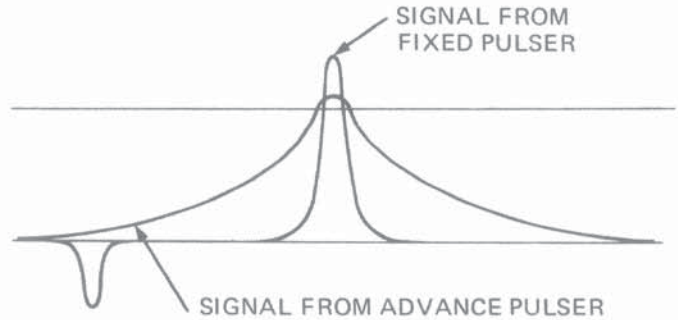

- PULSER WAVE FORMS DURING TIMING ADVANCE

With further increases in engine speed, a transition occurs in the wave form, such as from A to B. That is, SCR is triggered sooner to advance the ignition timing.

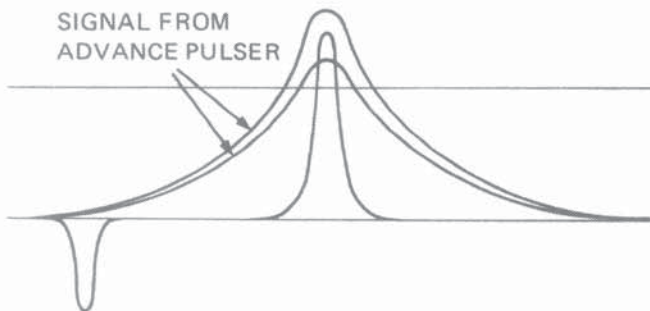

- PULSER WAVE FORMS AT END OF ADVANCE

The negative pulse from the fixed pulser balances the positive pulse from the advance pulser, causing the timing to stop advancing.

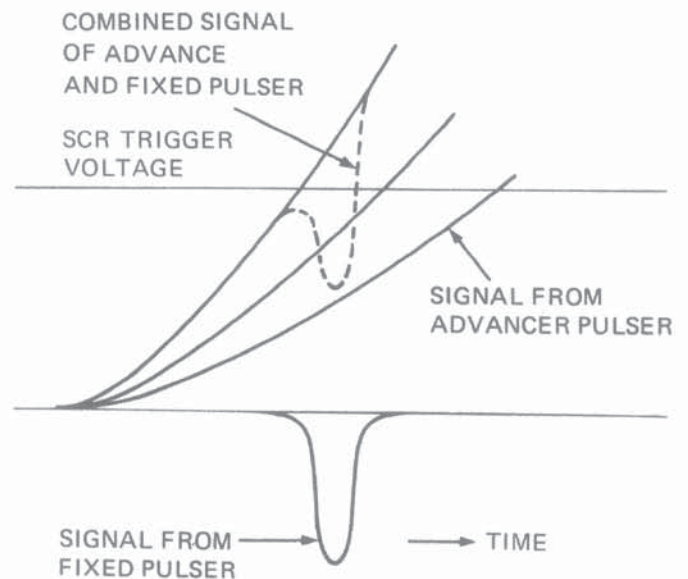





## TROUBLESHOOTING

- ENGINE DOES NOT START OR IS HARD TO START

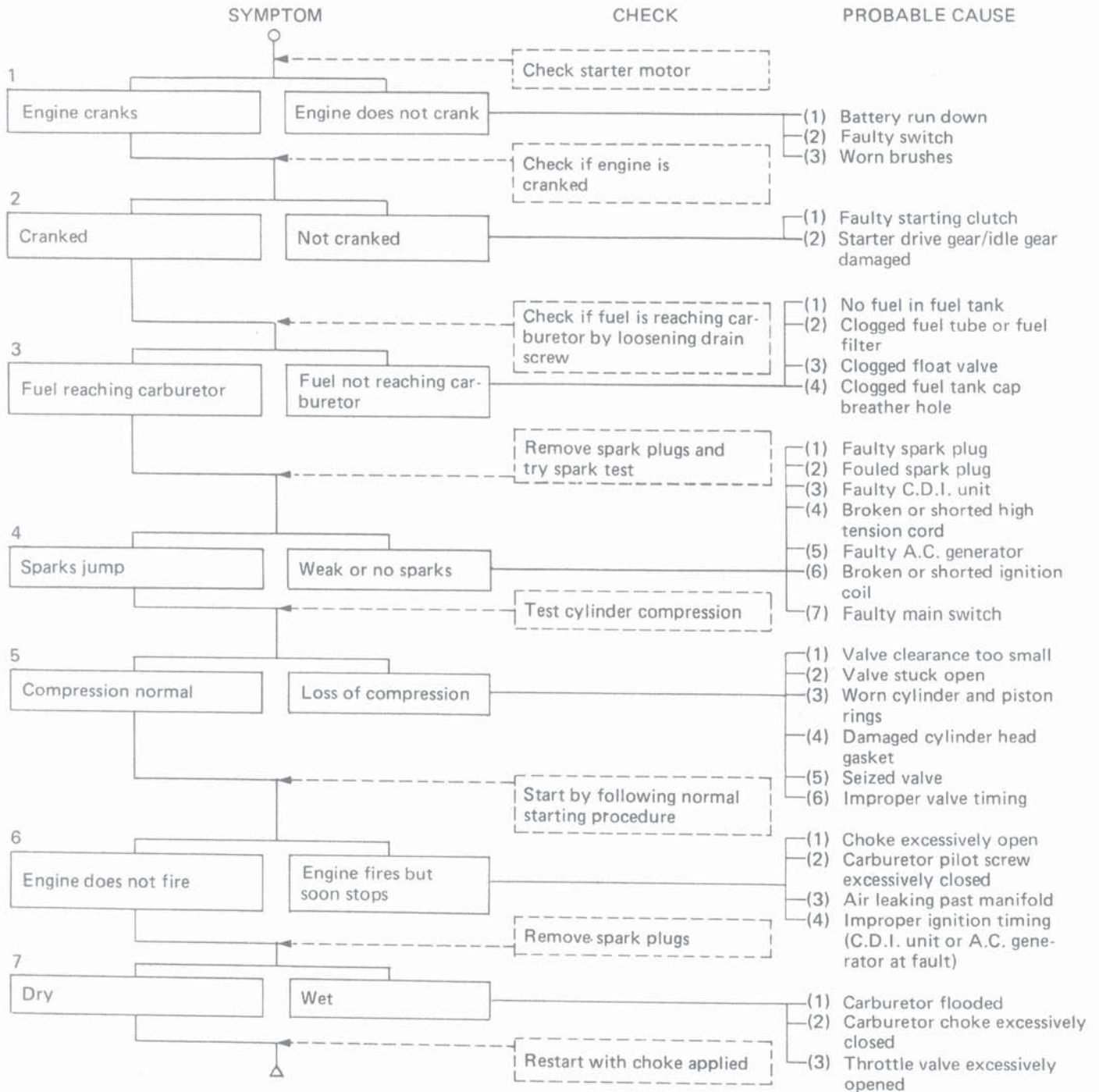



**TROUBLESHOOTING**

● **ENGINE LACKS POWER**

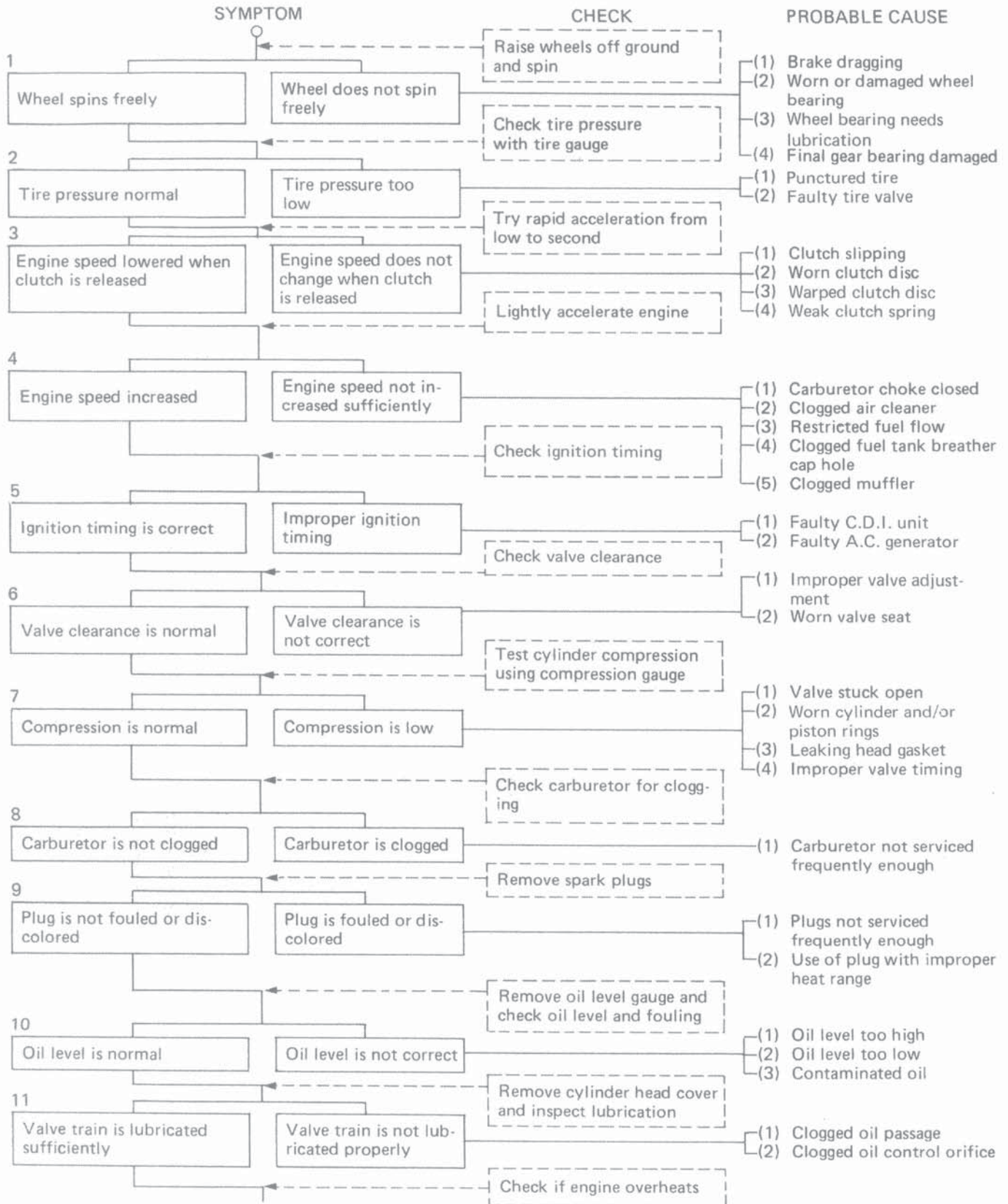



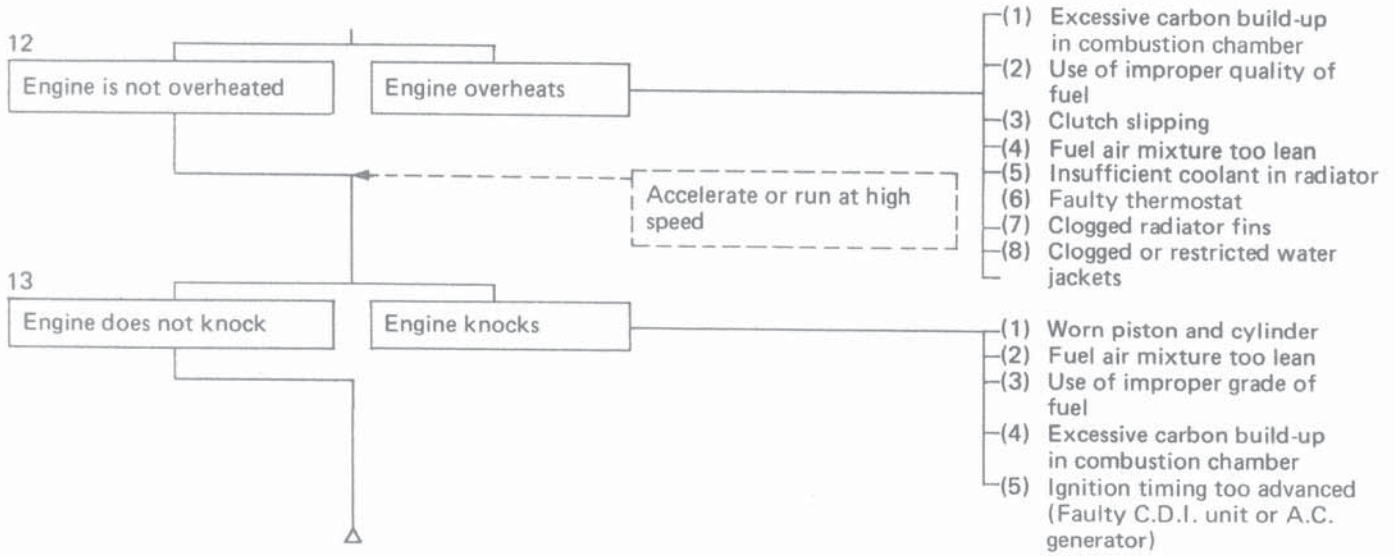

● POOR PERFORMANCE AT LOW AND IDLE SPEED

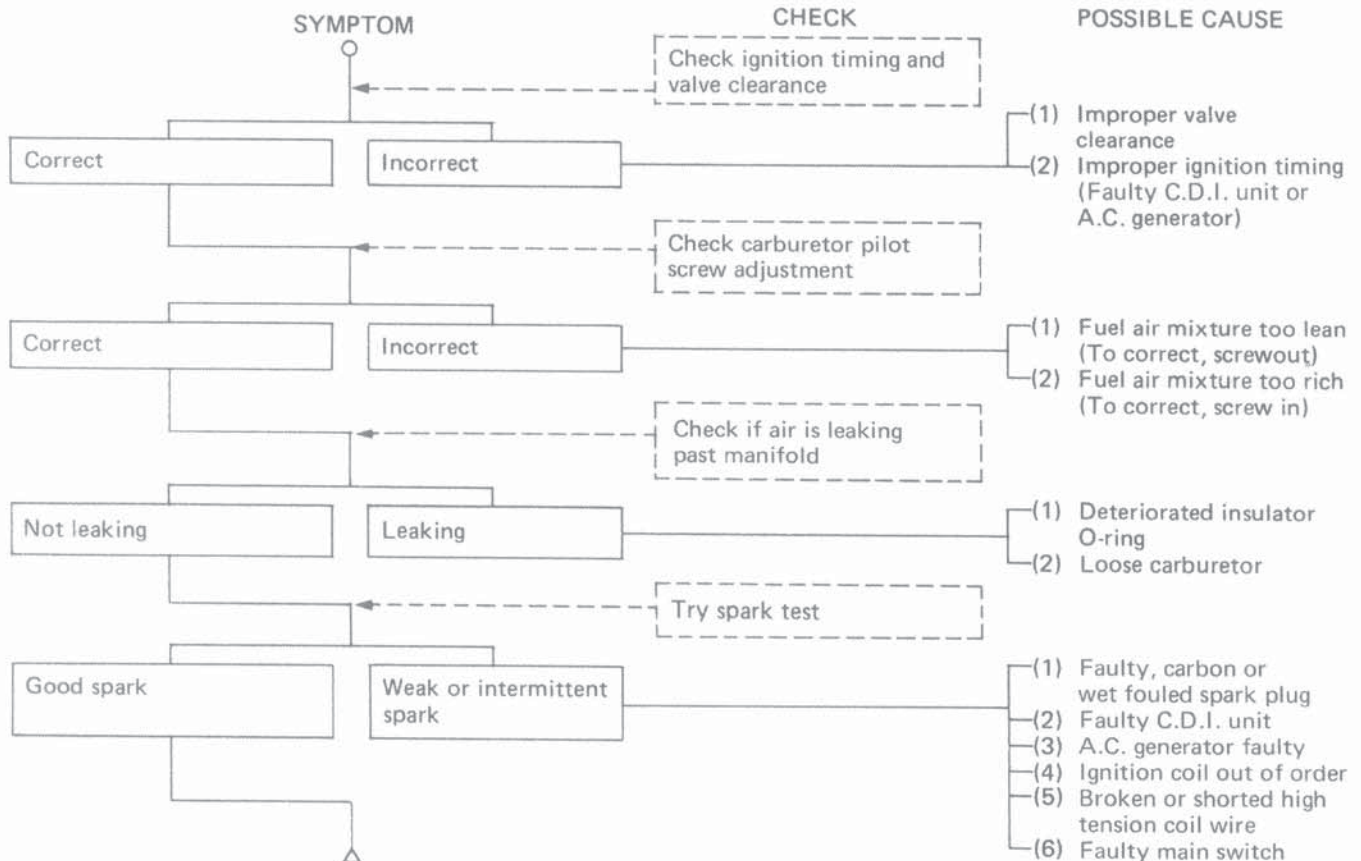



**TROUBLESHOOTING**

• **POOR PERFORMANCE AT HIGH SPEED**

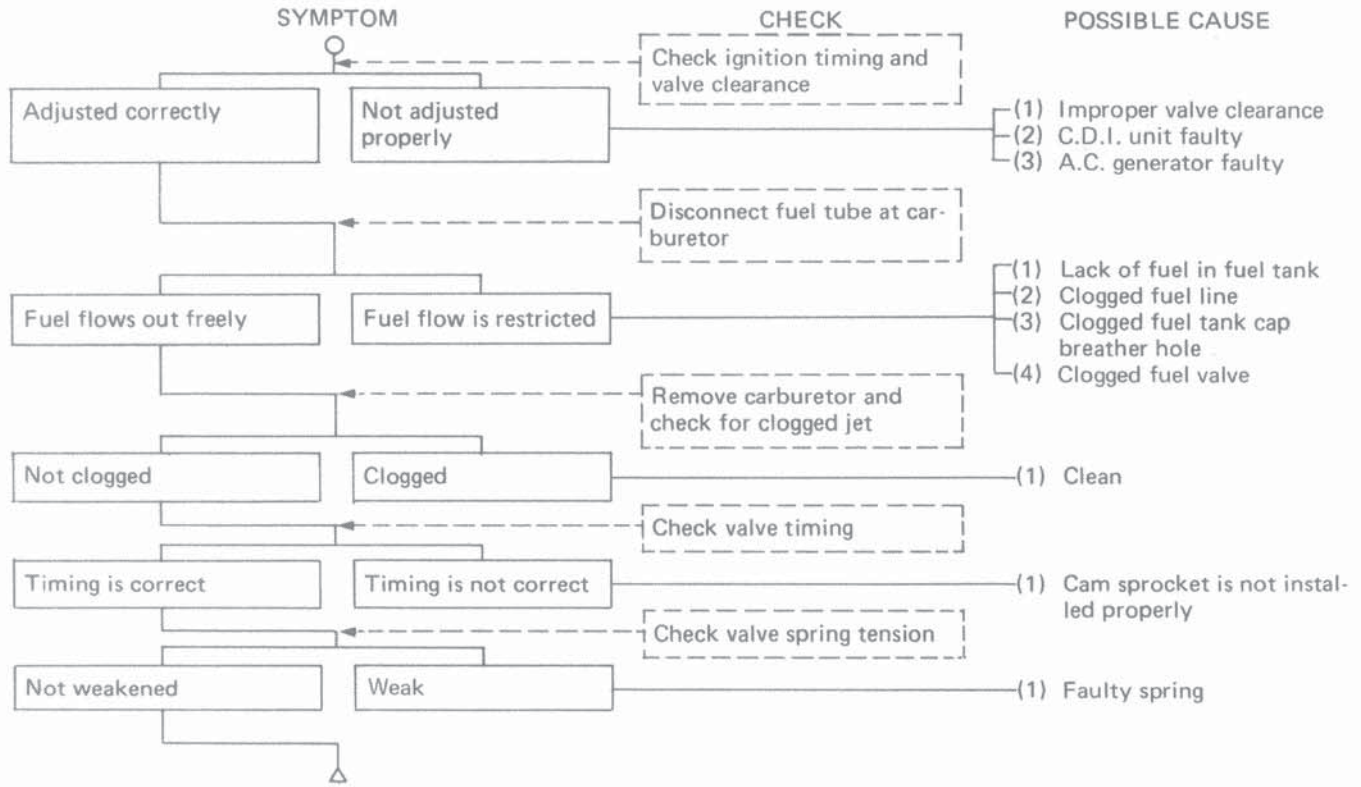

• **DOOR HANDLING**

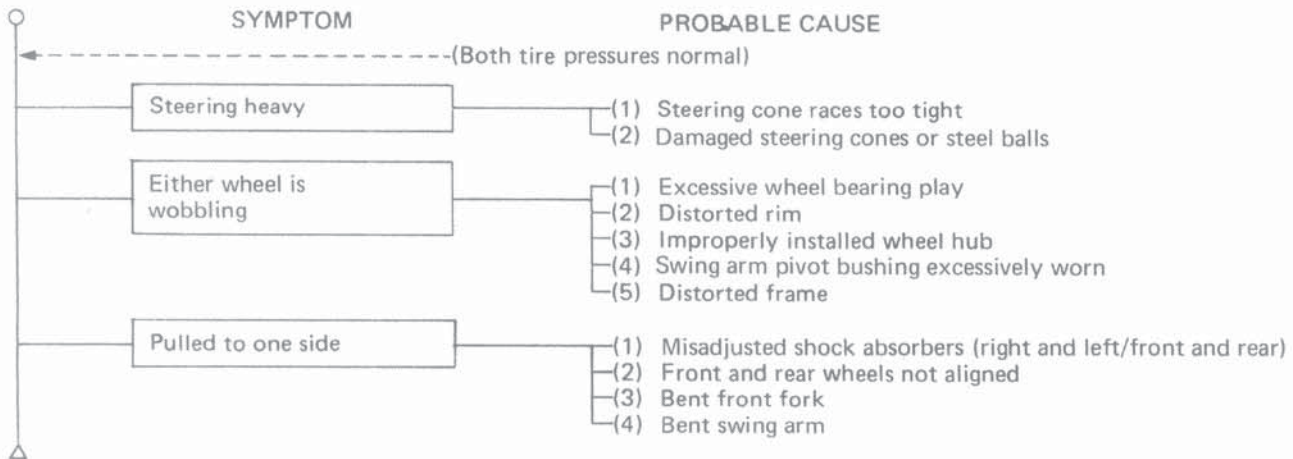





● **ENGINE NOISE**

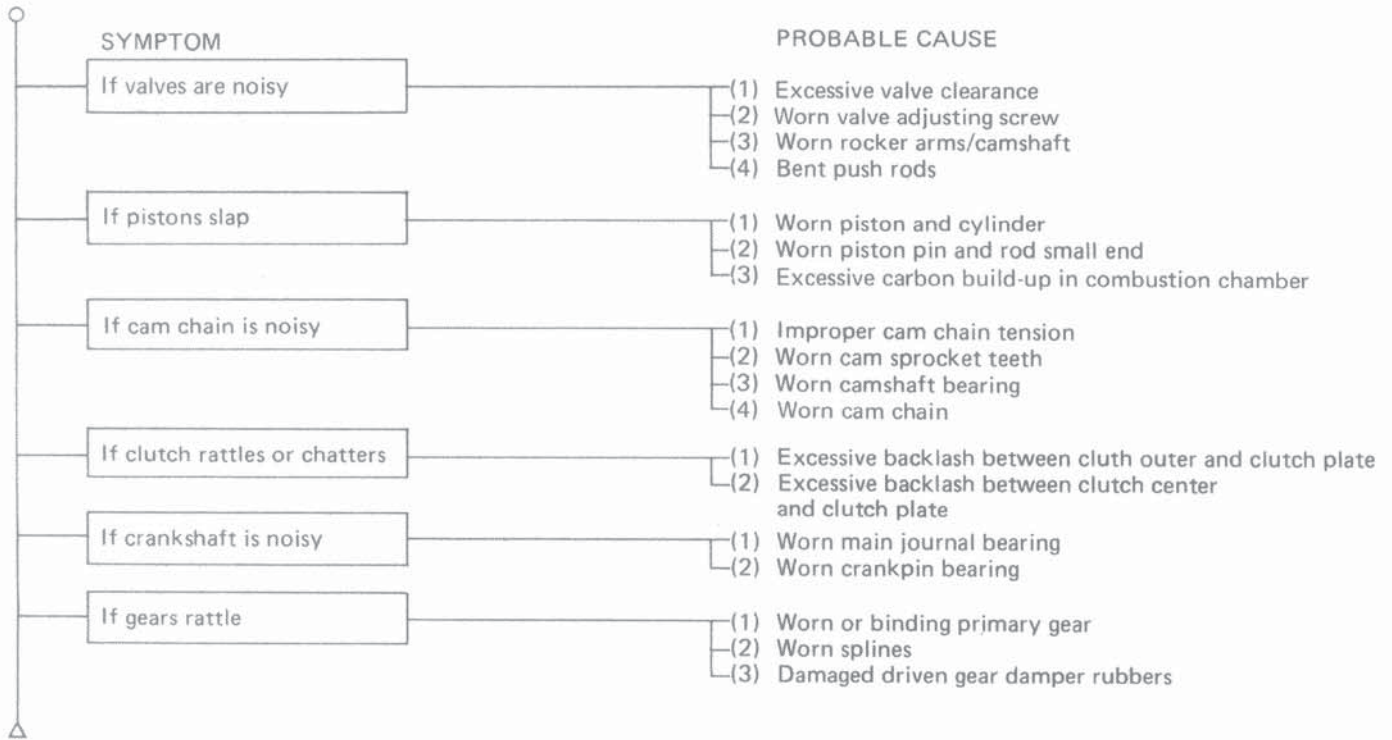

● **ENGINE OVERHEATS**

- (1) Insufficient coolant in radiator
- (2) Clogged radiator
- (3) Clogged water jackets
- (4) Damaged water pump impeller
- (5) Presence of air in cooling system
- (6) Faulty radiator cap
- (7) Loose cooling fan



## INTRODUCTION

This Honda Shop Manual Addendum contains information pertinent to the 1979 CX500.

Refer to the base Shop Manual for service procedures and data not included in this addendum.

ALL INFORMATION, ILLUSTRATIONS, DIRECTIONS AND SPECIFICATIONS INCLUDED IN THIS PUBLICATION ARE BASED ON THE LATEST PRODUCT INFORMATION AVAILABLE AT THE TIME OF APPROVAL FOR PRINTING. HONDA MOTOR CO., LTD. RESERVES THE RIGHT TO MAKE CHANGES AT ANY TIME WITHOUT NOTICE AND WITHOUT INCURRING ANY OBLIGATION WHATSOEVER.

NO PART OF THIS PUBLICATION MAY BE REPRODUCED WITHOUT WRITTEN PERMISSION.

HONDA MOTOR CO., LTD.  
Service Publications Office

## TABLE OF CONTENTS

1. GENERAL INFORMATION .....	21-2
TORQUE VALUES .....	21-2
MAINTENANCE SCHEDULE .....	21-3
CABLE & HARNESS ROUTING .....	21-4
2. INSPECTION AND ADJUSTMENT .....	21-5
BRAKE FLUID LEVEL .....	21-5
BRAKE FLUID REPLACEMENT .....	21-5
3. FRONT WHEEL/SUSPENSION .....	21-7
4. HYDRAULIC DISC BRAKE .....	21-8
SERVICE INFORMATION .....	21-8
TROUBLESHOOTING .....	21-8
MASTER CYLINDER .....	21-9





## 1. GENERAL INFORMATION

### TORQUE VALUES

#### <ENGINE>

Item	Q'ty	Thread Dia. (mm)	Torque Values	
			kg-m	ft-lb
Crankshaft cap	7	8	2.0 - 2.4	14 - 17
Connecting rod cap	4	8	2.8 - 3.2	20 - 23
Cylinder head	8	12	5.0 - 5.5	36 - 40
Valve adjusting nut	8	6	1.5 - 1.8	11 - 13
Flywheel	1	12	8.0 -10.0	58 - 72
Clutch center	1	20	8.0 -10.0	58 - 72
Primary drive gear	1	12	8.0 - 9.5	58 - 69
Starting clutch outer	3	8	1.8 - 2.5	13 - 18
Cooling fan	1	8	2.0 - 2.5	14 - 18
Cam shaft sprocket boss	1	20	8.0 -10.0	58 - 72
Cam shaft sprocket	2	7	1.6 - 2.0	12 - 14
Change pedal	1	6	1.0 - 1.4	7 - 10
Radiator drain bolt	1	12	0.15- 0.30	1.1- 2.2

#### <FRAME>

Item	Q'ty	Thread Dia. (mm)	Torque Values	
			kg-m	ft-lb
Steering stem nut	1	24	9.0 -12.0	65 - 87
Front fork top bridge	2	7	0.9 - 1.3	7 - 9
Handlebar lock	2	6	1.0 - 1.4	7 - 10
Handlebar holder	4	8	2.5 - 3.0	18 - 22
Front fork steering stem	2	8	1.8 - 2.5	13 - 18
Front and rear axles	1	14	5.5 - 6.5	40 - 47
Front axle holder	4	8	1.8 - 2.5	13 - 18
Engine hanger bolt	4	10	3.5 - 4.5	25 - 33
Engine hanger bolt	1	12	6.0 - 7.0	43 - 51
Final drive flange nut	3	10	3.5 - 4.5	25 - 33
Rear brake torque link	1	8	1.5 - 2.3	11 - 17
Rear shock absorber	4	10	3.0 - 4.0	22 - 29
Foot peg	2	10	3.0 - 4.0	22 - 29
Swing arm pivot nut	1	23	8.0 -12.0	58 - 87
Front brake disc	5	8	2.7 - 3.3	20 - 24
Gear case swing arm	3	10	3.5 - 4.5	25 - 33
Swing arm pivot bolt	1	23	0.8 - 1.2	6 - 9
Front caliper	2	10	3.0 - 4.0	22 - 29

Torque specifications listed above are for the most important tightening points. If a torque specification is not listed, follow the standards given below.

#### ● STANDARD TORQUE VALUES

Item	Torque Values kg-m (ft-lb)	Item	Torque Values kg-m (ft-lb)
5 mm bolt and nut	0.45-0.6 ( 3- 4)	5 mm screw	0.35-0.5 ( 3- 4)
6 mm bolt and nut	0.8 -1.2 ( 6- 9)	6 mm screw	0.7 -1.1 ( 5- 8)
8 mm bolt and nut	1.8 -2.5 (13-18)	6 mm flange bolt and nut	1.0 -1.4 ( 7-10)
10 mm bolt and nut	3.0 -4.0 (22-29)	8 mm flange bolt and nut	2.0 -3.0 (14-21)
12 mm bolt and nut	5.0 -6.0 (36-43)	10 mm flange bolt and nut	3.0 -4.0 (22-29)



## MAINTENANCE SCHEDULE

Perform the PRE-RIDE INSPECTION in the Owner's Manual at every maintenance period.

- I : INSPECT, CLEAN, ADJUST, LUBRICATE OR REPLACE IF NECESSARY.  
 C : CLEAN  
 R : REPLACE  
 A : ADJUST  
 L : LUBRICATE

ITEM	FREQUENCY	WHICHEVER COMES FIRST ↓ EVERY	ODOMETER READING [NOTE (3)]								REFER TO BASE SHOP MANUAL
			800 mi. (1,000 km)	3,750 mi. (6,000 km)	7,500 mi. (12,000 km)	11,250 mi. (18,000 km)	15,000 mi. (24,000 km)	18,750 mi. (30,000 km)	22,500 mi. (36,000 km)		
EMISSION RELATED ITEMS	ENGINE OIL	YEAR	R		R		R		R	Page 2- 2	
	ENGINE OIL FILTER	YEAR	R		R		R		R	Page 2- 2	
	CRANKCASE BREATHER	NOTE (1)		C	C	C	C	C	C	Page 3- 3	
	AIR CLEANER	NOTE (2)		C	R	C	R	C	R	Page 3- 2	
	* FUEL LINES				I		I		I	Page 3- 3	
	SPARK PLUGS			I	R	I	R	I	R	Page 3- 3	
	* VALVE CLEARANCE		I	I	I		I		I	Page 3- 4	
	* CAM CHAIN TENSION		A	A	A	A	A	A	A	Page 3- 5	
	* THROTTLE OPERATION		I		I		I		I	Page 3- 5	
	* CARBURETOR-IDLE SPEED		I	I	I	I	I	I	I	Page 3- 6	
	* CARBURETOR-CHOKE				I		I		I	Page 3- 6	
	* CARBURETOR-SYNCHRONIZE		I		I		I		I	Page 3- 7	
	* COOLANT				I		I		R	Page 3- 8 9- 3	
	* COOLING SYSTEM, HOSES		I		I		I		I	Page 3- 8	
	* RADIATOR CORE				I		I		I	Page 3- 8	
	NON-EMISSION RELATED ITEMS	* DRIVE SHAFT JOINT				L		L		L	Page 2- 3
		* FINAL DRIVE LUBRICANT				I		I		R	Page 2- 3
		BATTERY	MONTH	I	I	I	I	I	I	I	Page 3- 9
BRAKE FLUID (FRONT)		MONTH I 2 YEARS R	I	I	I	I	I	I	*R	Page 3- 9	
BRAKE SHOE/PAD WEAR				I	I	I	I	I	I	Page 3-11	
BRAKE SYSTEM			I		I		I		I	Page 3-11	
* BRAKE LIGHT SWITCH			I		I		I		I	Page 3-12	
* HEADLIGHT AIM			I		I		I		I	Page 3-13	
CLUTCH FREE PLAY			I	I	I	I	I	I	I	Page 3-13	
SIDE STAND					I		I		I	Page 3-14	
* SUSPENSION			I		I		I		I	Page 3-14	
* NUTS, BOLTS, FASTENERS			I		I		I		I	Page 3-15	
** WHEELS		I		I		I		I	Page 3-15		
** STEERING HEAD BEARING		I		I		I		I	Page 3-15		

\* SHOULD BE SERVICED BY AN AUTHORIZED HONDA DEALER, UNLESS THE OWNER HAS PROPER TOOLS AND SERVICE DATA AND IS MECHANICALLY QUALIFIED.

\*\* IN THE INTEREST OF SAFETY, WE RECOMMEND THESE ITEMS BE SERVICED ONLY BY AN AUTHORIZED HONDA DEALER.

- NOTE: (1) Service more frequently when riding in rain or at full throttle, or after being washed or overturned.  
 (2) Service more frequently when riding in dusty areas.  
 (3) For higher odometer readings, repeat at the frequency interval established here.





## CABLE & HARNESS ROUTING

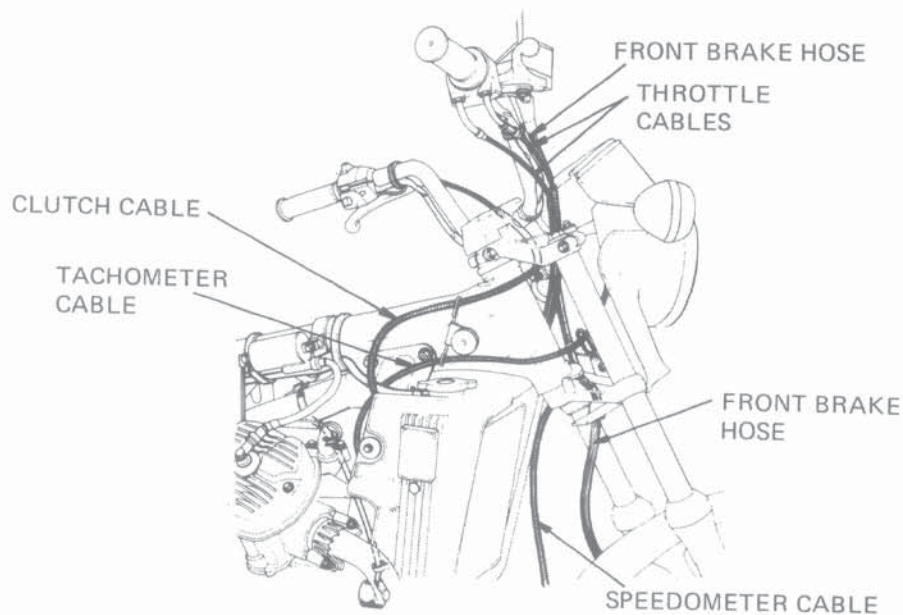
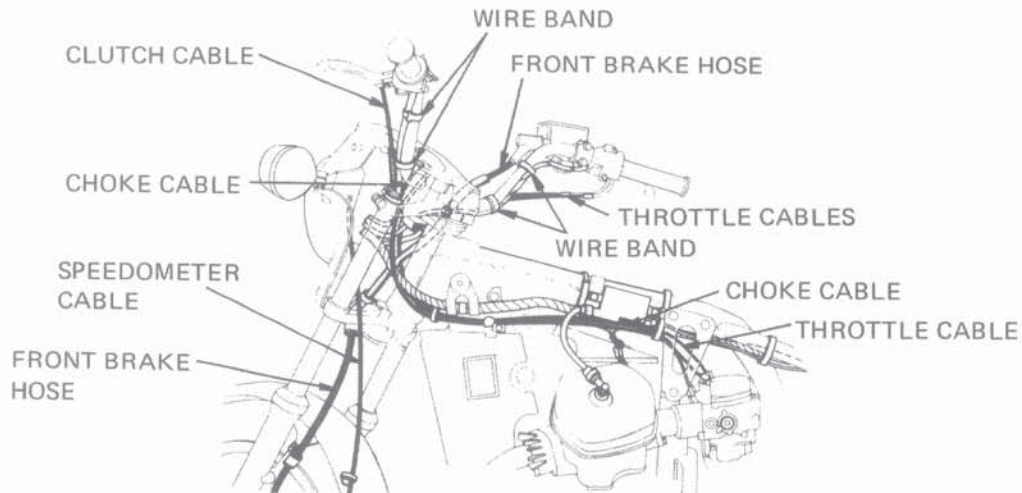
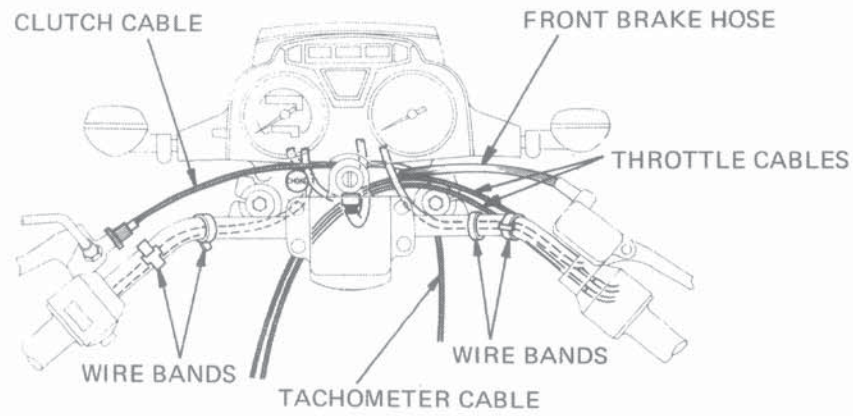



## 2. INSPECTION AND ADJUSTMENT

### BRAKE FLUID LEVEL

Check that the front brake fluid reservoir is filled to the upper level mark.

If the level is lower than the upper mark, fill the reservoir with DOT-3 BRAKE FLUID up to the upper level mark.

Check the entire system for leaks, if the level is low.

**CAUTION**

- Do not remove the cap until the handlebar has been turned full left so that the reservoir is level.
- Avoid operating the brake lever with the cap removed. Brake fluid will squirt out if the lever is pulled.

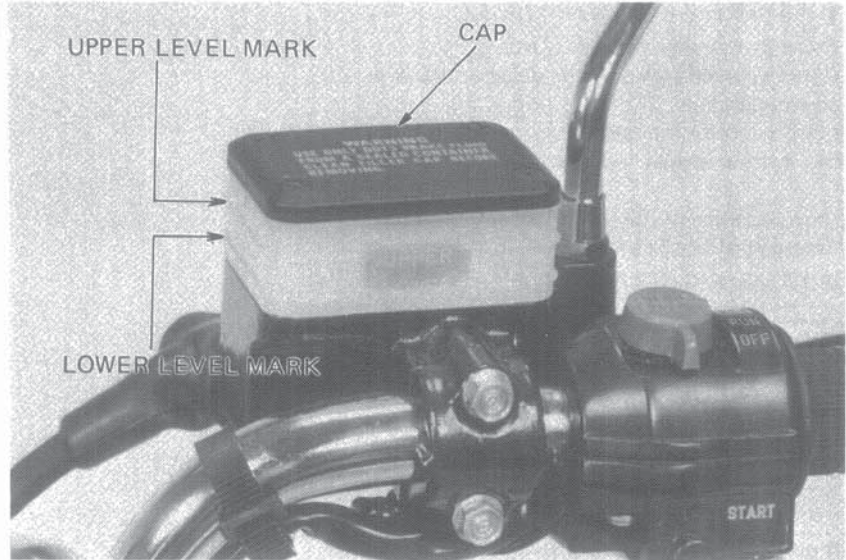

### BRAKE FLUID REPLACEMENT

Check the fluid level with the fluid reservoir parallel with the ground.

**CAUTION**

Be sure to install the diaphragm on the reservoir when operating the brake lever to prevent fluid from squirting out. Avoid spilling fluid on painted surfaces. Place a rag over the fuel tank whenever the system is serviced.

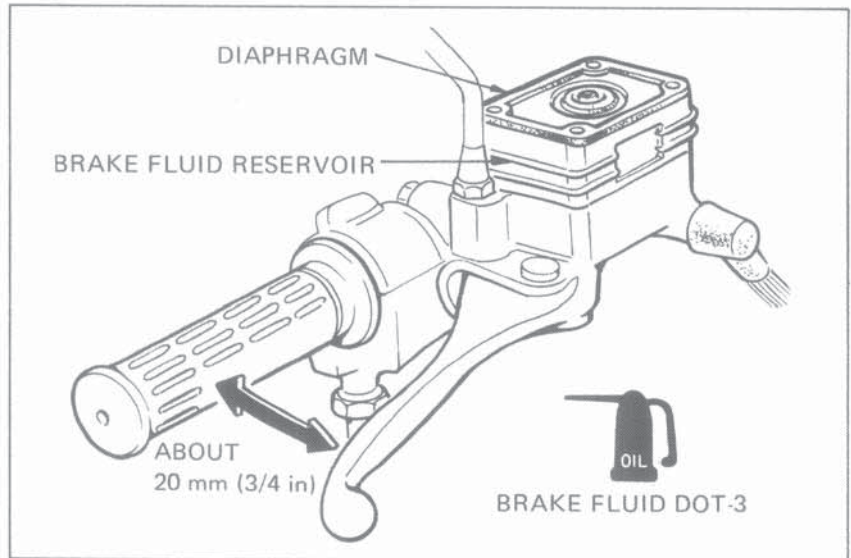





● **BRAKE FLUID DRAINING**

Remove the bleeder valve dust cap.  
Connect a bleed hose and place one end in a clean container.

Loosen the caliper bleeder valve and pump up the system pressure by operating the brake lever.

Stop operating the lever when no fluid is flowing out of the bleeder valve.

● **BRAKE FLUID FILLING**

**CAUTION**

*Check the fluid level often while bleeding the brake, to prevent air from being pumped into the system.  
Do not mix different brands of fluid since they are not compatible.*

Close the bleeder valve, fill the reservoir, and install the diaphragm.

To prevent piston overtravel and brake fluid seepage, keep a 20 mm space between the lever and the handlebar grip when bleeding the front brake system.

Pump up the system pressure with the lever until there are no air bubbles in the fluid flowing out of the reservoir small hole and lever resistance is felt.

● **AIR BLEEDING**

Pull the brake lever all the way back to the handlebar grip. Open the bleeder valve about 1/2 turn, and close.

**NOTE**

*Do not release the lever until the bleeder valve has been closed.*

Release the lever gradually and wait several seconds after it reaches the end of its travel before repeating the above steps. Continue until there are no air bubbles in the fluid flowing out of the bleeder valve.

Fill the reservoir to the UPPER LEVEL MARK.

Check the entire system for leaks by operating the lever.

**WARNING**

*A contaminated brake disc or pads reduces stopping power. Replace contaminated pads, and clean a contaminated disc with a good quality degreasing agent.*

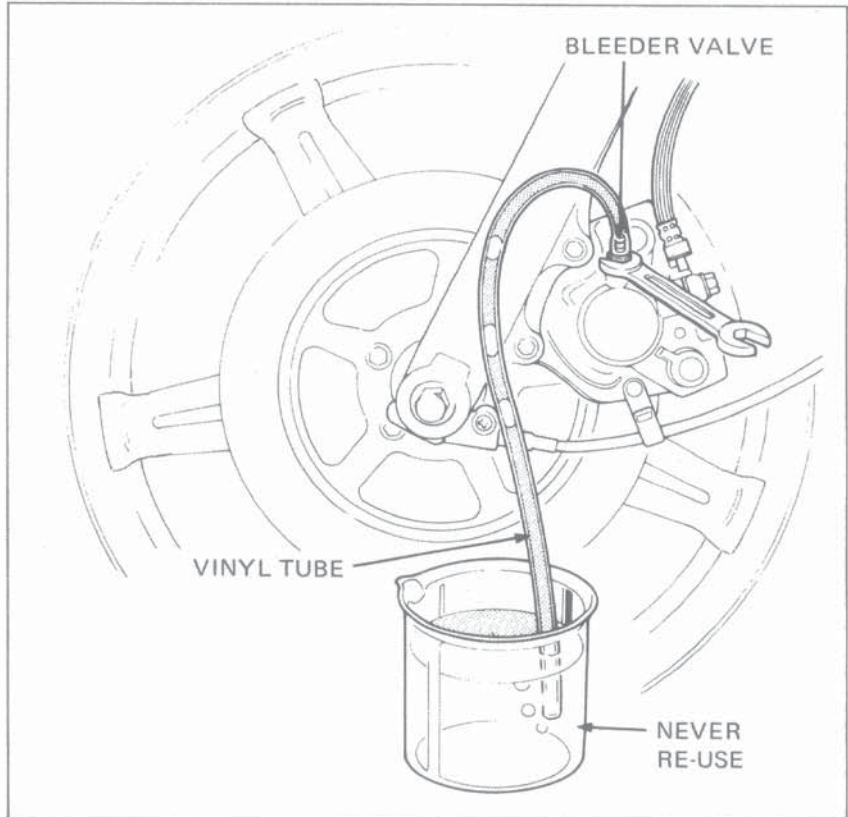



### 3. FRONT WHEEL/SUSPENSION

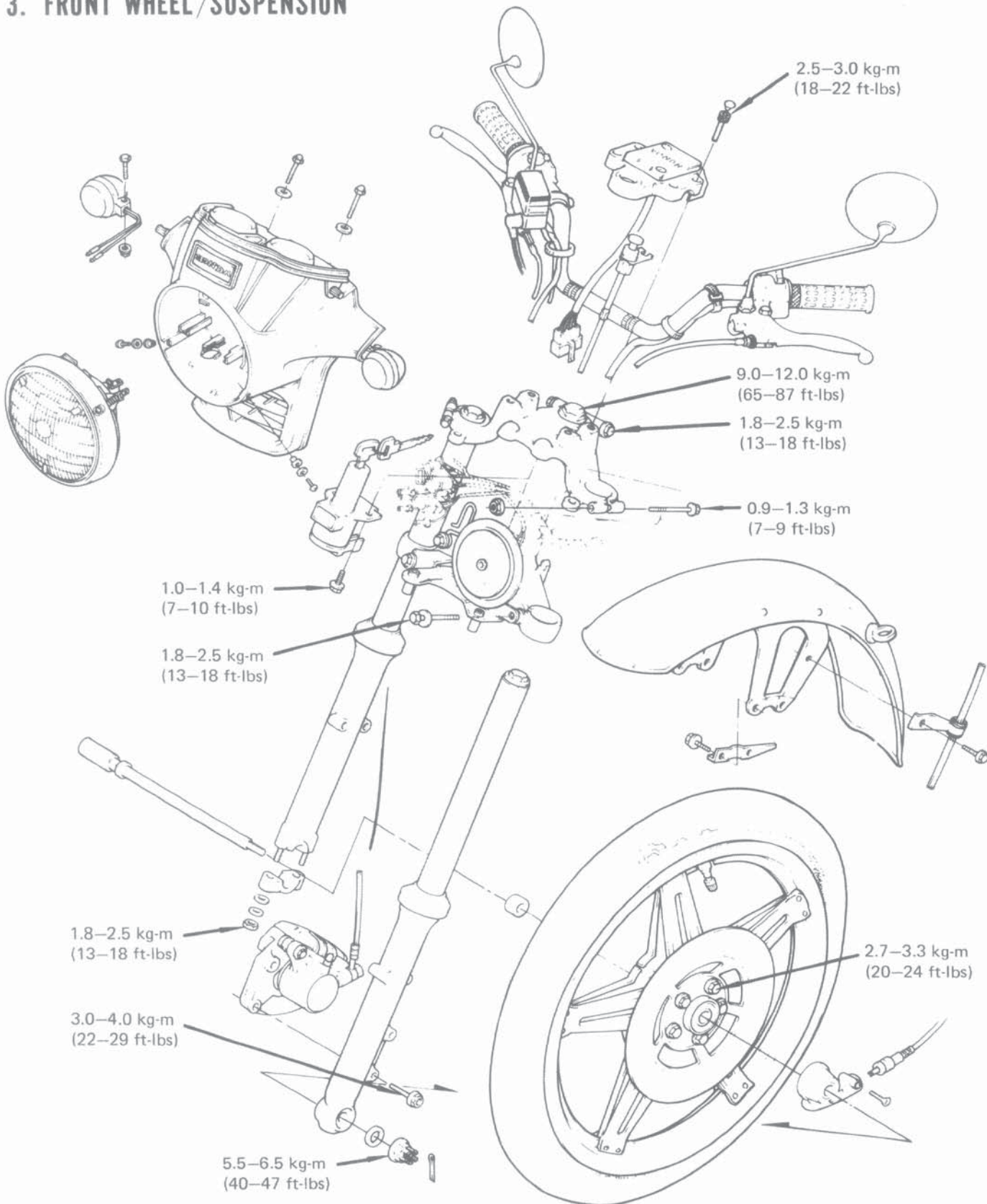





## 4. HYDRAULIC DISC BRAKE

SERVICE INFORMATION	21-9
TROUBLESHOOTING	21-9
BRAKE MASTER CYLINDER	21-10

### SERVICE INFORMATION

- SPECIAL TOOL  
SNAP RING PLIERS                    07914-3230001

- SPECIFICATIONS

	STANDARDS		SERVICE LIMIT	
	Disc thickness	6.8 – 7.2 mm	(0.27 – 0.28 in.)	6.0 mm
Disc runout	—		0.3 mm	(0.012 in.)
Master cylinder I.D.	14.000 – 14.043 mm (0.5512 – 0.5529 in.)		14.055 mm (0.5533 in.)	
Master piston O.D.	13.957 – 13.984 mm (0.5495 – 0.5506 in.)		13.945 mm (0.5490 in.)	
Caliper piston O.D.	42.772 – 42.822 mm (1.6839 – 1.6859 in.)		42.765 mm (1.6837 in.)	
Caliper cylinder I.D.	42.850 – 42.900 mm (1.6870 – 1.6890 in.)		42.915 mm (1.6896 in.)	

### TROUBLESHOOTING

#### Poor Brake Performance

1. Air bubbles in hydraulic system
2. Worn brake pads
3. Pads fouled or glazed
4. Hydraulic system leaking



## BRAKE MASTER CYLINDER

### • MASTER CYLINDER DISASSEMBLY

Drain brake fluid from the hydraulic system. Remove the brake lever and rear view mirror from the master cylinder. Disconnect and secure the brake hose.

**CAUTION**

*Avoid spilling brake fluid on painted surfaces.  
Place a rag over the fuel tank whenever the brake system is serviced.*

**NOTE**

Cover the end of the hose to prevent contamination.

Remove the master cylinder.

Remove the snap ring.  
Clean the interior of the master cylinder and reservoir with brake fluid.

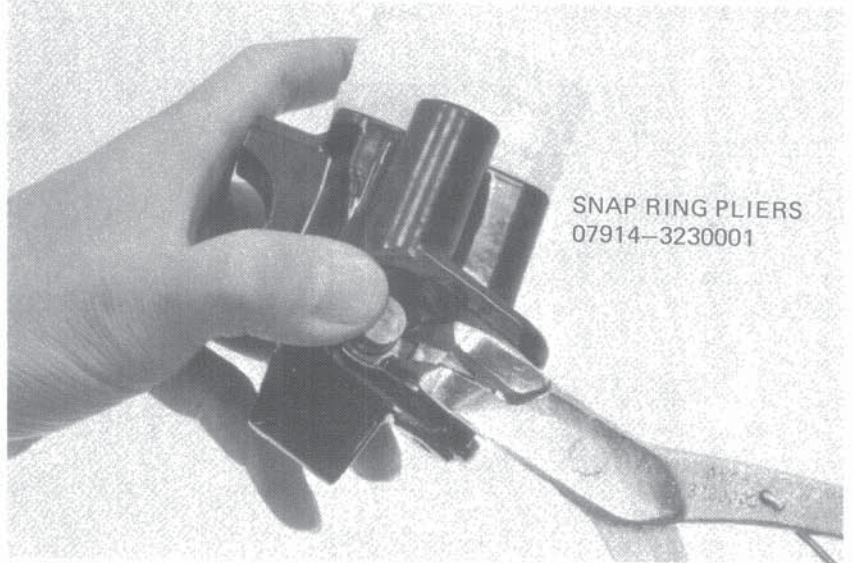
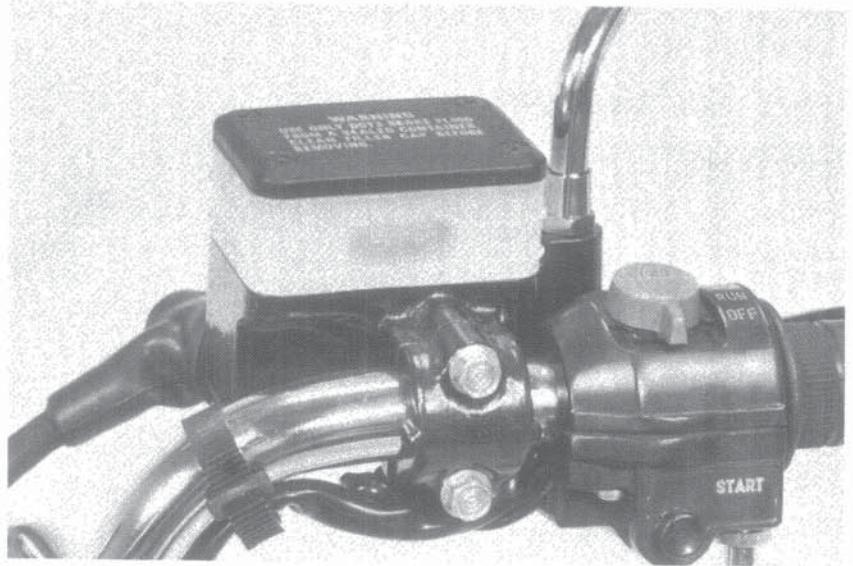

SNAP RING PLIERS  
07914-3230001

### • MASTER CYLINDER I.D. INSPECTION

Measure the master cylinder I.D.  
Check the master cylinder for scores, scratches or nicks.

**SERVICE LIMIT: 14.055 mm (0.5533 in)**

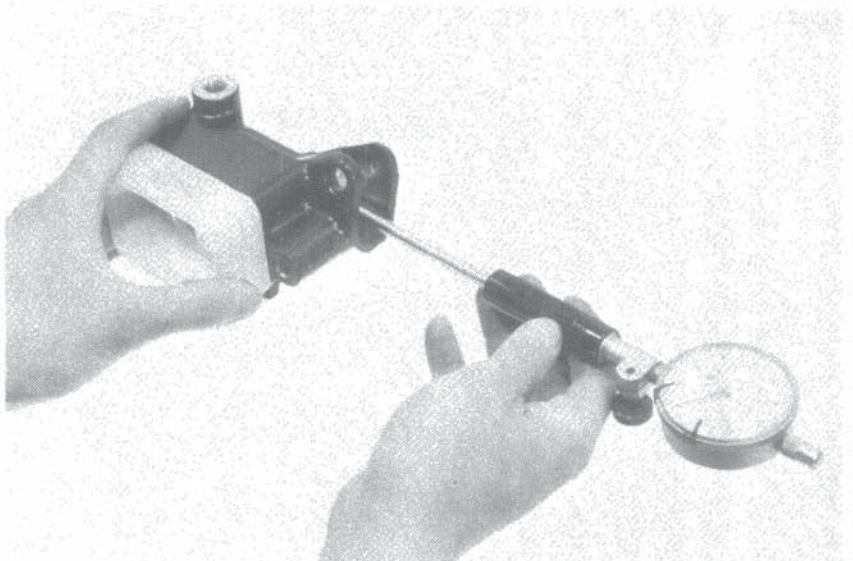





● MASTER CYLINDER PISTON O.D. INSPECTION

Measure the master cylinder piston O.D.

**SERVICE LIMIT: 13.945 mm (0.5490 in)**

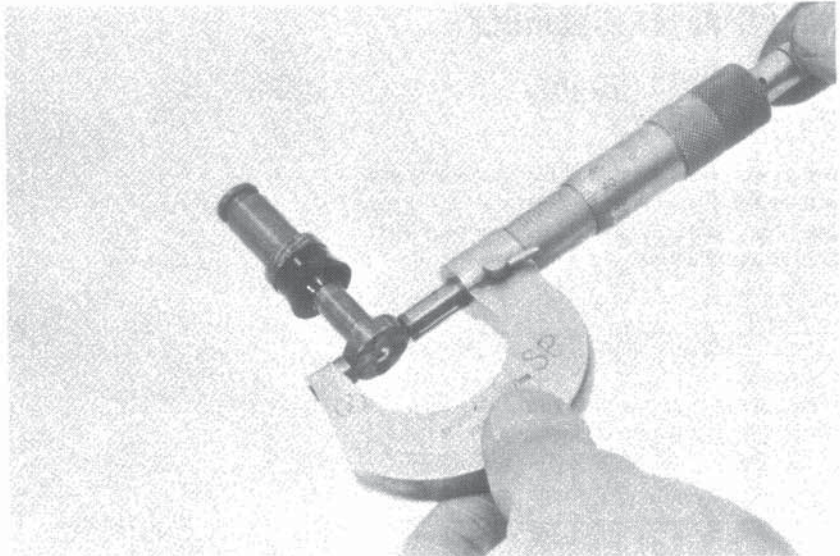

● MASTER CYLINDER ASSEMBLY

**CAUTION**

*Replace the master cylinder piston, cylinder and spring as a set.*

Assemble the master cylinder. Coat all parts with clean brake fluid before assembly. Insert the spring into the master cylinder. Dip the piston cup in brake fluid before assembly.

**CAUTION**

*When installing the cups, do not allow the lips to turn inside out. Be certain the circlip is seated firmly in the groove.*

Install the boot, washer and clip. Install the reservoir on the master cylinder making sure that the O-ring is in good condition.

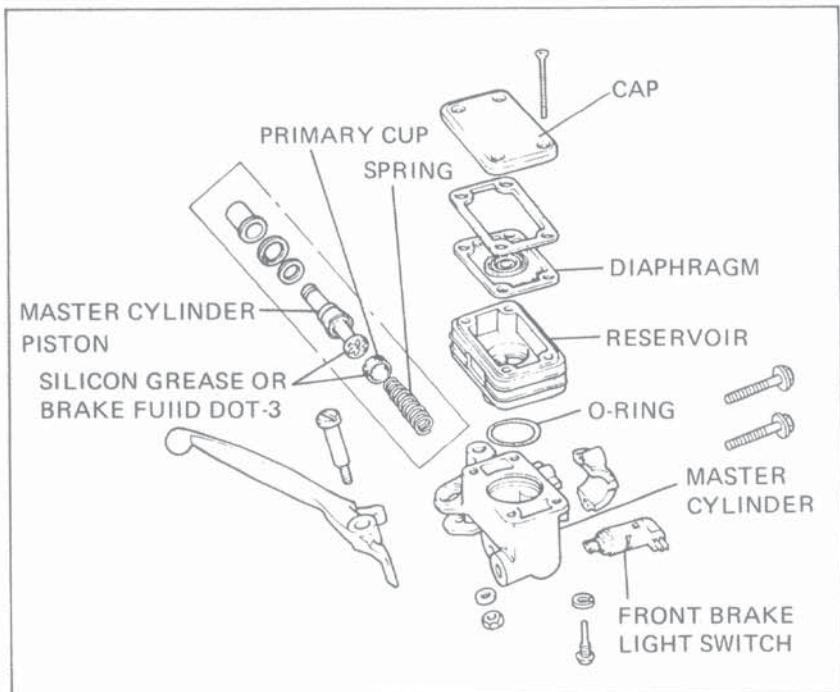



## INTRODUCTION

This Addendum contains information for the 1979 CX500 DELUXE and CUSTOM models.

Refer to the base Shop Manual and the previous Addendum for service procedures and data not included in this addendum.

ALL INFORMATION, ILLUSTRATIONS, DIRECTIONS AND SPECIFICATIONS INCLUDED IN THIS PUBLICATION ARE BASED ON THE LATEST PRODUCT INFORMATION AVAILABLE AT THE TIME OF APPROVAL FOR PRINTING. HONDA MOTOR CO., LTD. RESERVES THE RIGHT TO MAKE CHANGES AT ANY TIME WITHOUT NOTICE AND WITHOUT INCURRING ANY OBLIGATION WHATEVER.

NO PART OF THIS PUBLICATION MAY BE REPRODUCED WITHOUT WRITTEN PERMISSION.

HONDA MOTOR CO., LTD.  
Service Publications Office

## TABLE OF CONTENTS

MODEL IDENTIFICATION .....	22- 2
SPECIFICATIONS .....	22- 3
WIRING DIAGRAM .....	22- 5
CABLE & HARNESS ROUTING .....	22- 6
RADIATOR COVER .....	22- 9
SEAT & FUEL TANK .....	22- 9
HEADLIGHT .....	22-10
INSTRUMENTS .....	22-11
REAR SHOCK ABSORBER .....	22-13
OIL PRESSURE/STOP LAMP WARNING INDICATOR .....	22-14





**MODEL IDENTIFICATION**

DELUXE

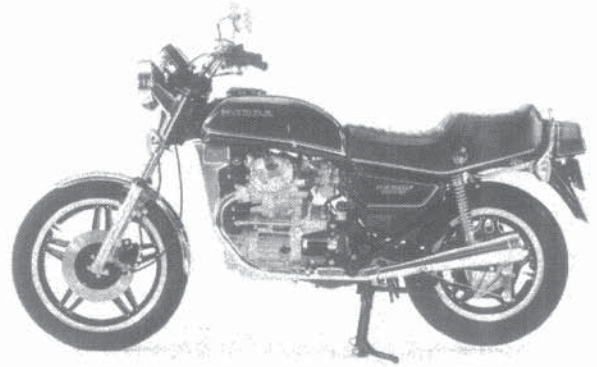
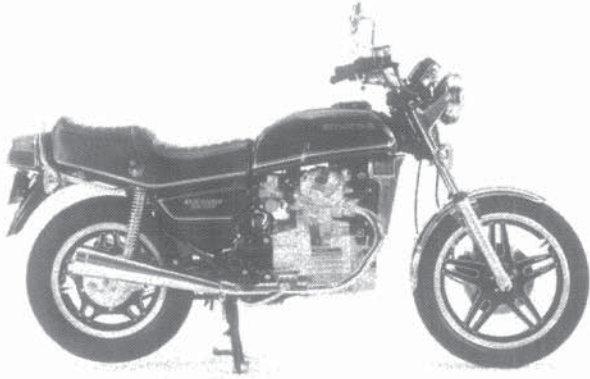

CUSTOM

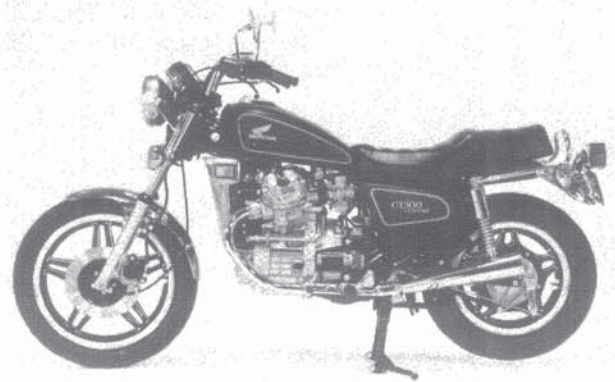
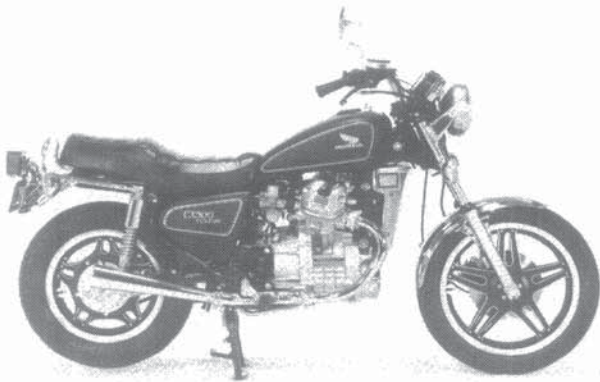



**SPECIFICATIONS**

ITEM		SPECIFICATIONS		
		DELUXE	CUSTOM	
DIMENSIONS	Overall length	2,185 mm (86.0 in)	2,150 mm (84.6 in)	
	Overall width	865 mm (34.1 in)	875 mm (34.4 in)	
	Overall height	1,165 mm (45.9 in)	1,170 mm (46.1 in)	
	Wheelbase	1,455 mm (57.3 in)	1,455 mm (57.3 in)	
	Seat height	800 mm (31.5 in)	790 mm (31.1 in)	
	Foot peg height	335 mm (13.2 in)	325 mm (12.8 in)	
	Ground clearance	145 mm ( 5.7 in)	145 mm ( 5.7 in)	
	Dry weight	205 kg (452 lb)	202 kg (445 lb)	
FRAME	Type	Diamond		
	Front suspension, travel	Telescopic fork, 139.5 mm (5.5 in)		
	Rear suspension, travel	Swingarm, 85 mm (3.3 in)		
	Front tire size	3.50S19-4PR		
	Rear tire size	130/90-16 67S		
	Cold tire pressures	Up to 90 kg (200 lbs) load	Front Rear	2.0 kg/cm <sup>2</sup> (28 psi) 2.0 kg/cm <sup>2</sup> (28 psi)
		Up to vehicle capacity load	Front Rear	2.0 kg/cm <sup>2</sup> (28 psi) 2.25 kg/cm <sup>2</sup> (32 psi)
Front brake, lining swept area	Disc brake, 601 cm <sup>2</sup> (93.2 sq in)			
Rear brake, lining swept area	Internal expanding shoes, 201 cm <sup>2</sup> (31.2 sq in)			
Fuel capacity	17 liters (4.5 US gal)		11 liters (2.9 US gal)	
	3.5 liters (0.9 US gal)		2.5 liters (0.7 US gal)	
Caster angle	63° 15'			
Trail	105 mm (4.1 in)			
Front fork oil capacity	135 cc (4.6 ozs) After assembly			
ENGINE	Type	Liquid cooled 4-stroke OHV		
	Cylinder arrangement	2 cylinder transverse V		
	Bore and stroke	78 x 52 mm (3.071 x 2.047 in)		
	Displacement	496 cc (30.3 cu in)		
	Compression ratio	10:1		
	Valve train	Silent chain driven camshaft and push rod		
	Oil capacity	3.0 liters (3.2 US qt) After draining		
	Lubrication system	Forced pressure and wet sump		
	Cooling system capacity	2.0 liters (0.52 US gal)		
	Air filtration	Paper filter		
	Cylinder compression	12 kg/cm <sup>2</sup> (171 psi)		
	Intake valve	Opens	6° BTDC (at 1 mm lift), 75° BTDC (at 0 lift)	
		Closes	46° ABDC (at 1 mm lift), 115° ABDC (at 0 lift)	
	Exhaust valve	Opens	46° BBDC (at 1 mm lift), 111° BBDC (at 0 lift)	
		Closes	6° ATDC (at 1 mm lift), 71° ATDC (at 0 lift)	
	Valve clearance	IN: 0.08 mm (0.003 in)		
		EX: 0.10 mm (0.004 in)		
Engine weight	65 kg (143 lb)			
Idle speed	1,100 ± 100 rpm			





ITEM		SPECIFICATIONS																							
		DELUXE			CUSTOM																				
CARBURETION	Carburetor type	CV 35 mm (1.4 in)																							
	Identification number	VB23A			VB27A																				
	Pilot screw Float level	See page 4-10 15.5 mm (0.61 in)																							
DRIVE TRAIN	Clutch Transmission Primary reduction Gear ratio I Gear ratio II Gear ratio III Gear ratio IV Gear ratio V Final reduction Gear shift pattern	Wet, multi-plate 5-speed, constant-mesh 2.242 2.733 1.850 1.416 1.148 0.931 3.091 (11/34) Left foot operated return system 1-N-2-3-4-5																							
ELECTRICAL	Ignition Ignition timing "F" mark Full advance RPM from "F" to full advance Starting system Generator Battery capacity Spark plug  Spark plug gap Fuse	CDI 15° BTDC 37° ± 3° BTDC 1,750-6,000 rpm Starting motor only Three phase A.C. generator 170 w/5,000 rpm 12V-14AH USA model <table border="1" data-bbox="787 1018 1437 1207"> <thead> <tr> <th colspan="2">For cold climate below 5°C (41° F)</th> <th colspan="2">Standard</th> <th colspan="2">For extended high speed riding</th> </tr> <tr> <th>ND</th> <th>NGK</th> <th>ND</th> <th>NGK</th> <th>ND</th> <th>NGK</th> </tr> </thead> <tbody> <tr> <td>X22ES-U</td> <td>D7EA</td> <td>X24ES-U</td> <td>D8EA</td> <td>X27ES-U</td> <td>D9EA</td> </tr> </tbody> </table> Canadian model ND X24ESR-U, NGK DR8ES-L 0.6-0.7 mm (0.024-0.028 in) 20A (main), 10A (sub)						For cold climate below 5°C (41° F)		Standard		For extended high speed riding		ND	NGK	ND	NGK	ND	NGK	X22ES-U	D7EA	X24ES-U	D8EA	X27ES-U	D9EA
For cold climate below 5°C (41° F)		Standard		For extended high speed riding																					
ND	NGK	ND	NGK	ND	NGK																				
X22ES-U	D7EA	X24ES-U	D8EA	X27ES-U	D9EA																				
LIGHTS	Headlight (high/low beam) Tail/stoplight Turn signal light (front/rear) Speedometer light Tachometer light Neutral indicator light Turn signal indicator light High beam indicator light Running light	65/50W sealed beam 8/27W (3/32 cp SAE NO. 1157) 23/23W (32/32 cp SAE NO. F. 1034, R. 1073) 3.4W (2 cp SAE NO. 57) 3.4W (2 cp SAE NO. 57) 3.4W (2 cp SAE NO. 57) 3.4W (2 cp SAE NO. 57) 3.4W (2 cp SAE NO. 57) 3.4W (2 cp SAE NO. 57) 8W (3 cp SAE NO. 1034)																							



CS500

'79 DELUXE AND CUSTOM ADDENDUM

WIRING DIAGRAM (CS500 DELUXE AND CUSTOM)

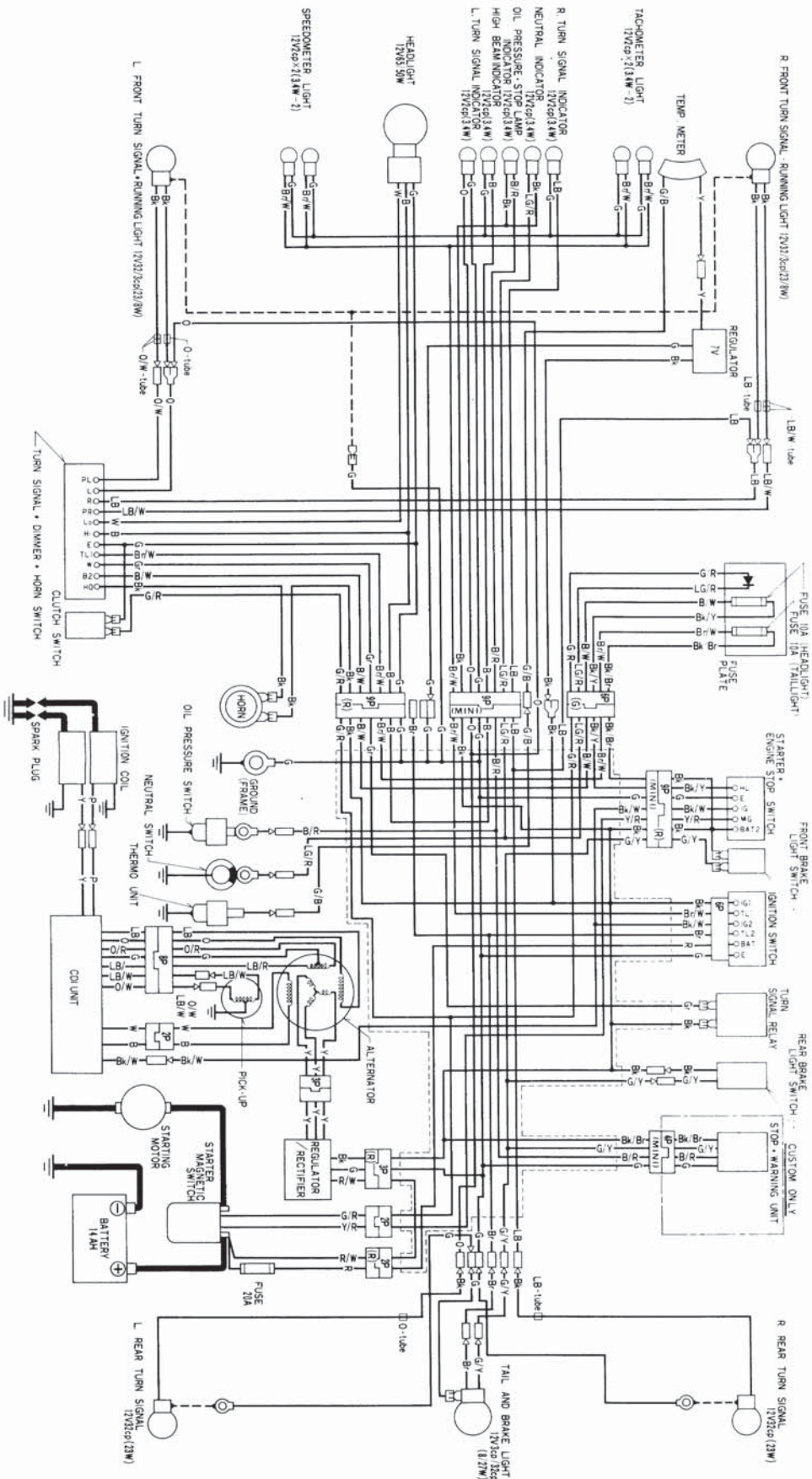

IGNITION SWITCH CONTINUITY

OFF	E	IG2	BAT	IG1	TL1	TL2
ON	○	○	○	○	○	○
LOOK	○	○	○	○	○	○

STARTER ENGINE STOP SWITCH CONTINUITY

OFF	IG	E	STARTER SWITCH	NG	BAT2	HL1
ON	○	○	○	○	○	○
LOOK	○	○	○	○	○	○

TURN SIGNAL DIMMER+HORN SWITCH CONTINUITY

OFF	B2	L3	H1	H2	E
ON	○	○	○	○	○
LOOK	○	○	○	○	○

TURN SIGNAL SWITCH CONTINUITY

OFF	W	R	L	TL1	PR	PL
ON	○	○	○	○	○	○
LOOK	○	○	○	○	○	○

Color Legend:

B	Brown	Y	Yellow
W	White	B	Blue
L6	Light Green	Gr	Grey
R	Red	LB	Light Blue
G	Green	O	Orange
		P	Pink

0030Z-449-6700





### CABLE & HARNESS ROUTING DELUXE

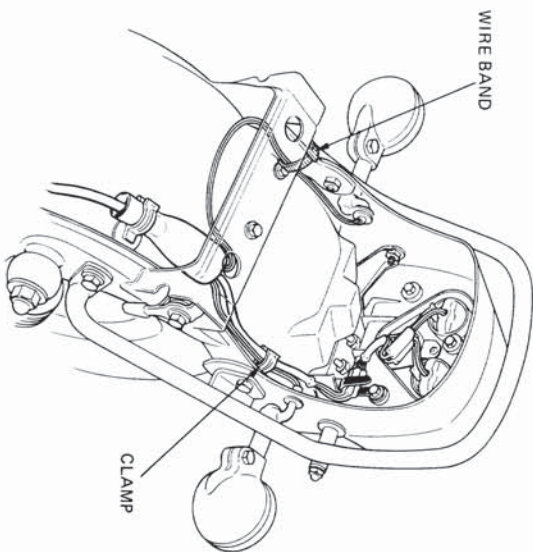
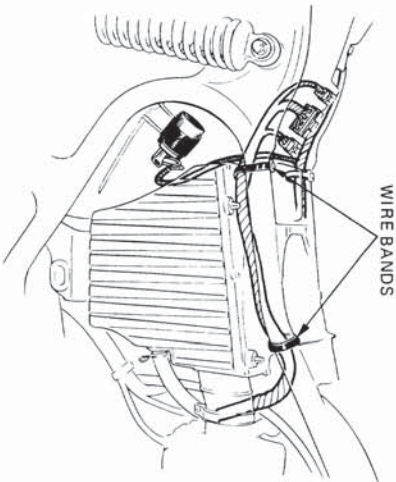
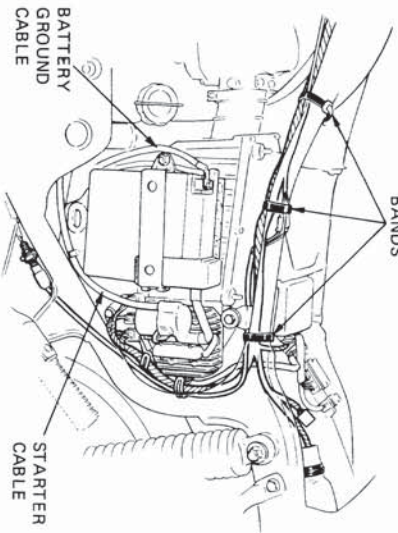
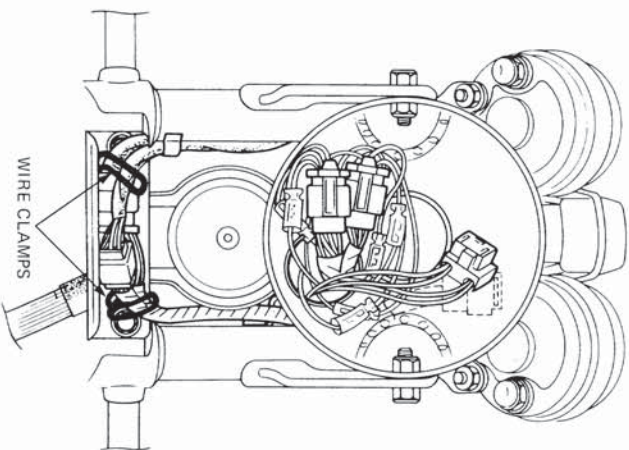
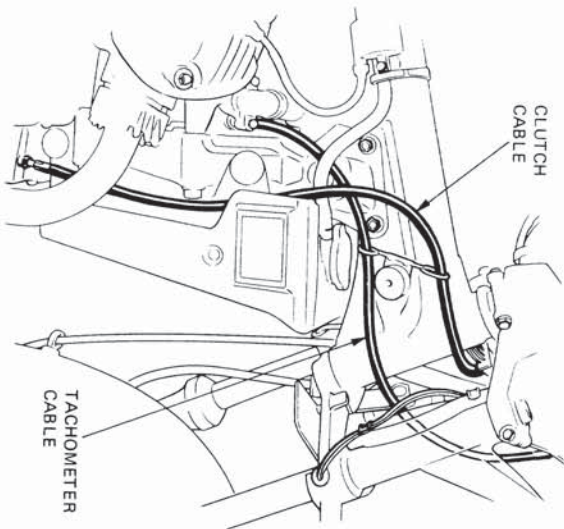
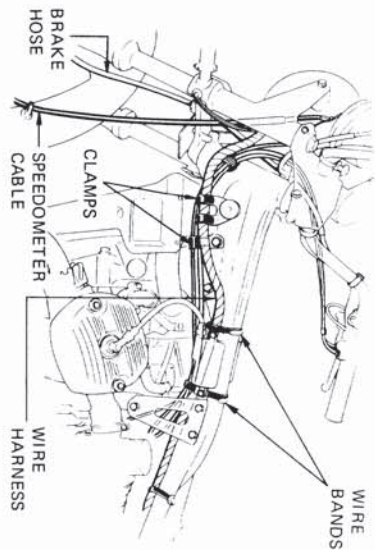
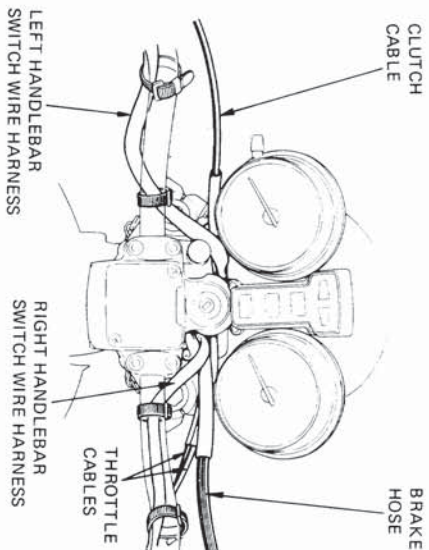



CUSTOM

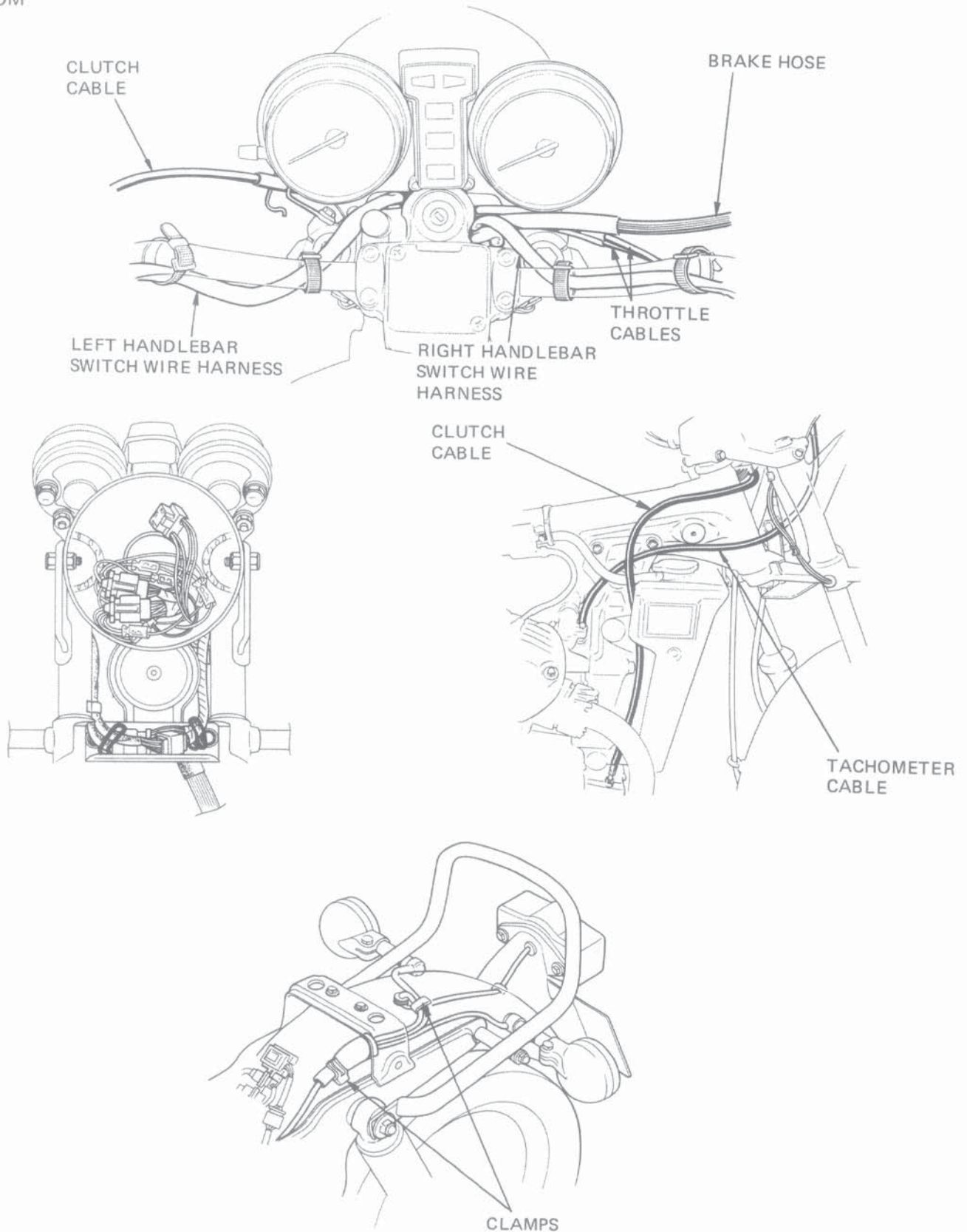



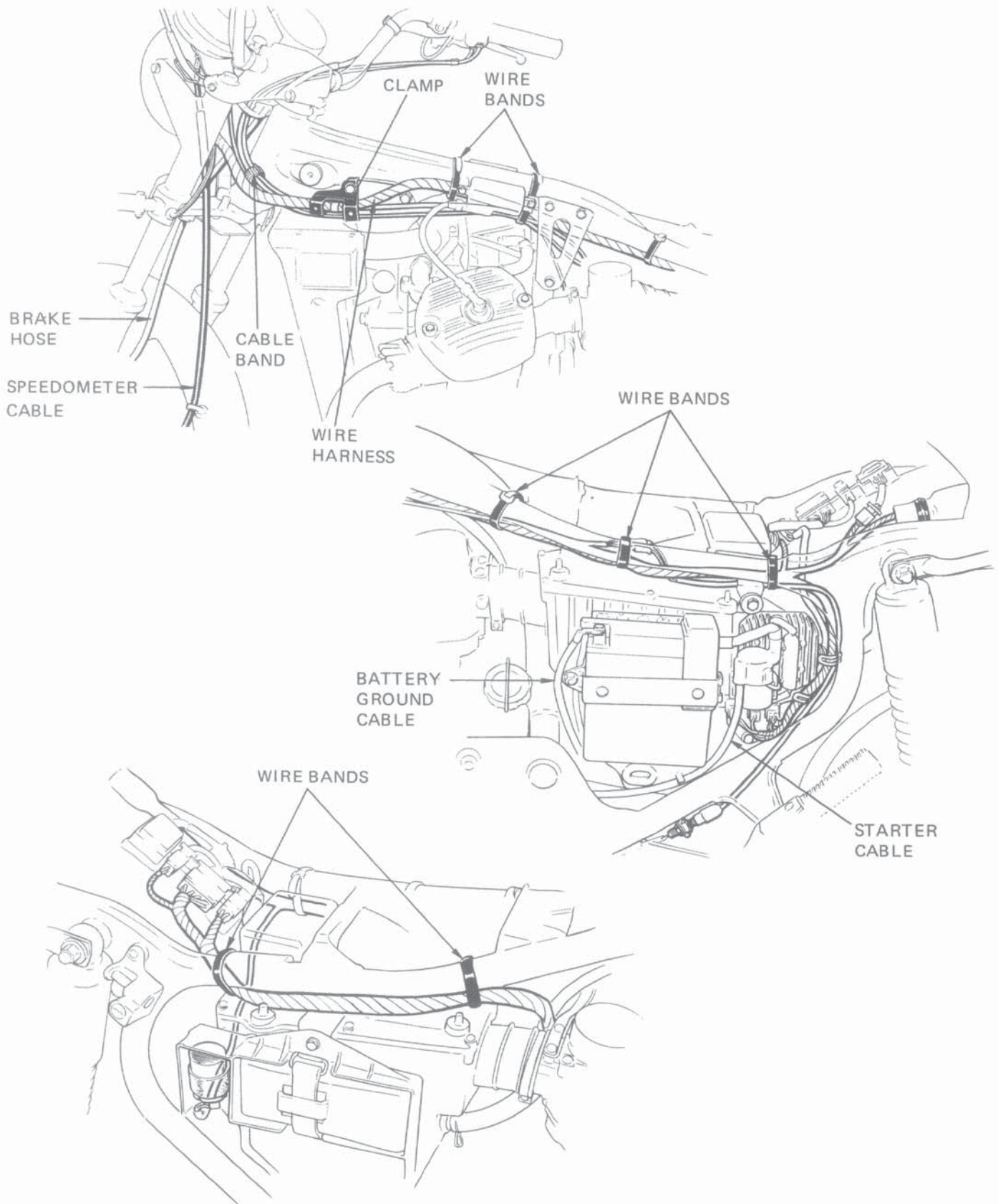



## RADIATOR COVER

- REMOVAL

Remove the radiator cover mounting screws and the right and left covers. Remove the radiator grill.

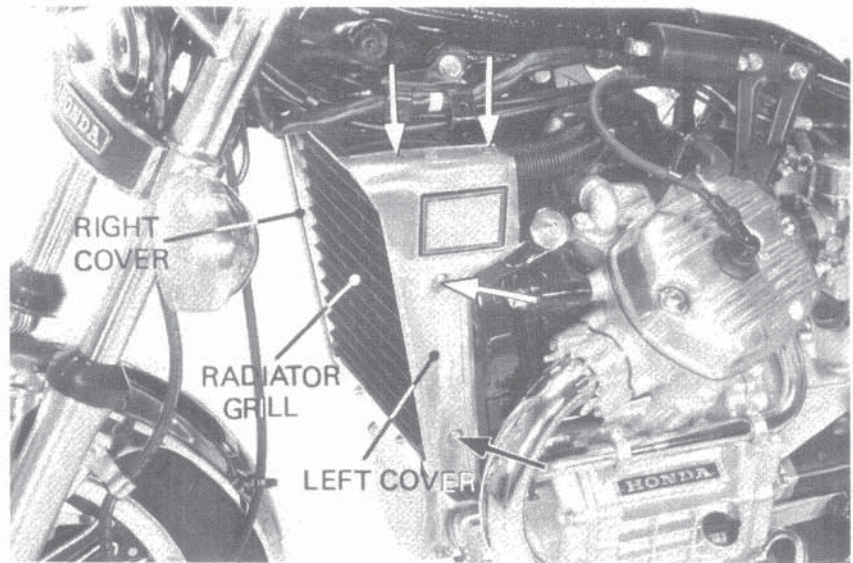

## CUSTOM : SEAT AND FUEL TANK

- REMOVAL

Remove the two seat mounting bolts and the seat.

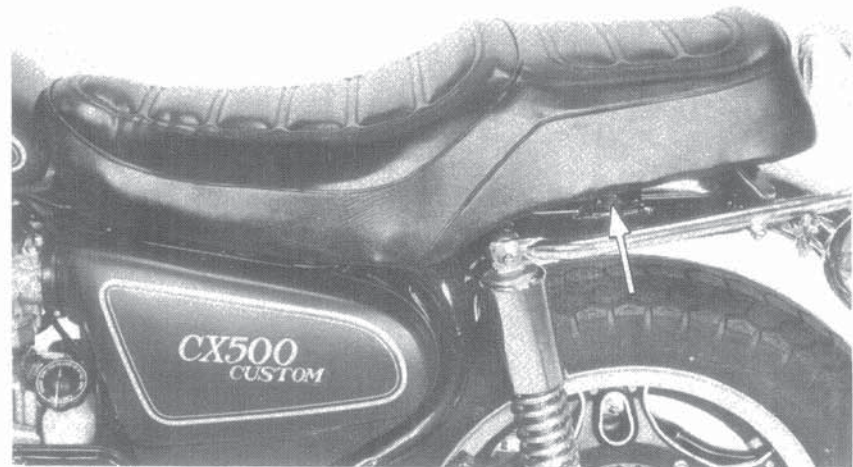

Turn the fuel valve OFF and disconnect the fuel line at the fuel valve.

Remove the three fuel tank mounting bolts and the fuel tank.







## HEADLIGHT

### • HEADLIGHT CASE REMOVAL

Remove the headlight.

Disconnect all wires at their couplers and connectors.

Unscrew the headlight case mounts and remove the case.

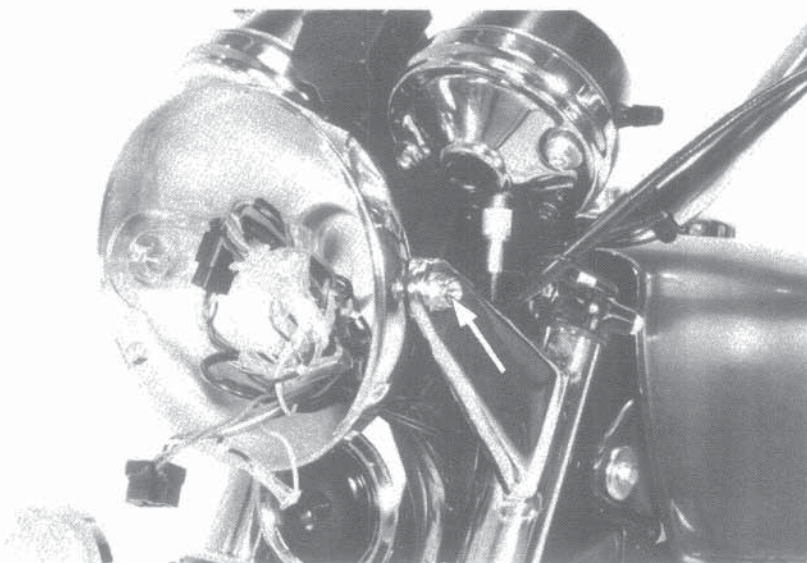

### • HEADLIGHT DISASSEMBLY/ ASSEMBLY

Remove the retaining screws and horizontal adjusting screw from the rim.

Remove the two headlight unit retaining screws, and headlight unit.

Assembly is the reverse of disassembly.

ADJUSTING  
SCREW

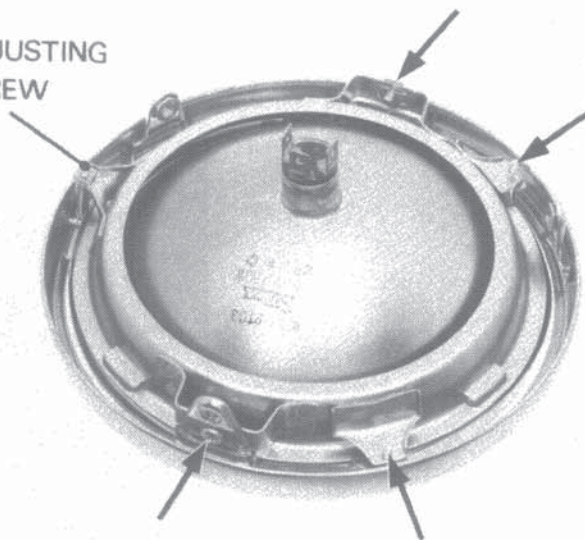

### • HEADLIGHT CASE INSTALLATION

Align the punch marks on the headlight case and bracket.

Connect all wires at their couplers and connectors.

#### NOTE

Check each component for operation after assembling.

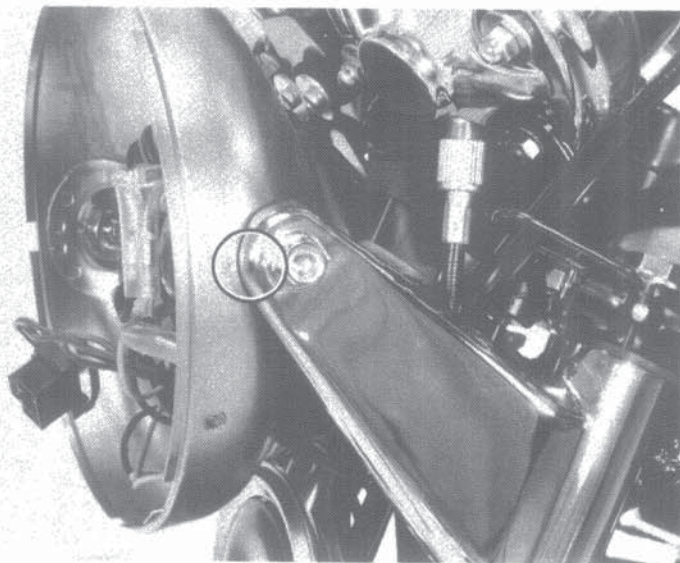





Connect the headlight coupler.  
Align the headlight thread holes with the headlight case holes.  
Secure the headlight with three screws.

• **HEADLIGHT AIM ADJUSTMENT**

Vertical adjustment is made by loosening both headlight case mounting bolts.  
Adjust horizontally by turning the adjusting screw on the headlight rim.  
Turn the adjusting screw counterclockwise to direct the beam toward the right side of the rider.

**NOTE**

Adjust the headlight beam as specified by local and state laws.

**WARNING**

*An improperly adjusted headlight may blind oncoming drivers, or it may fail to light the road for a safe distance.*

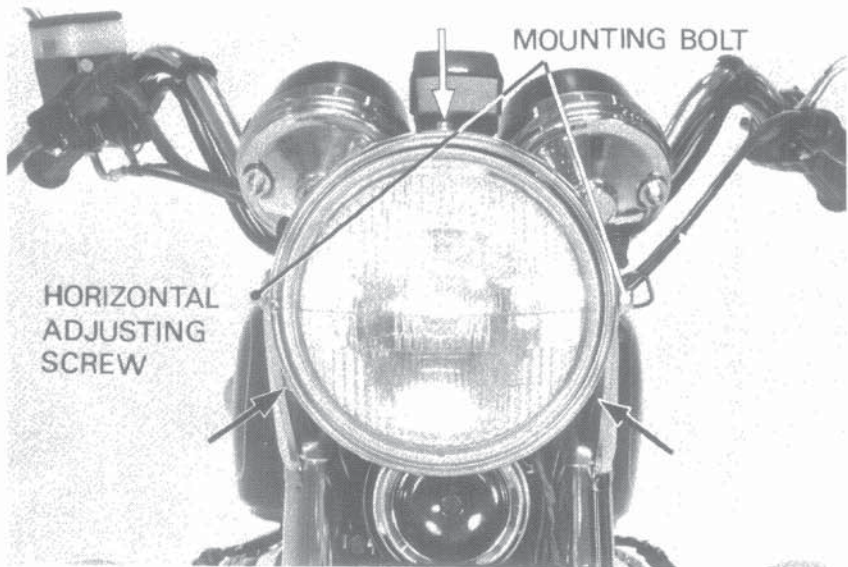

**INSTRUMENTS**

• **INDICATOR BULB REPLACEMENT**

Remove the indicator light panel screws and panel.  
Replace the bulb.  
If the replacement bulb does not light, check for loose connections, a short or open circuit.

• **METER ILLUMINATION BULB REPLACEMENT**

Disconnect the meter cable.  
Remove the meter mounting nuts and meter.  
Remove the bulb socket.  
Replace the bulb.

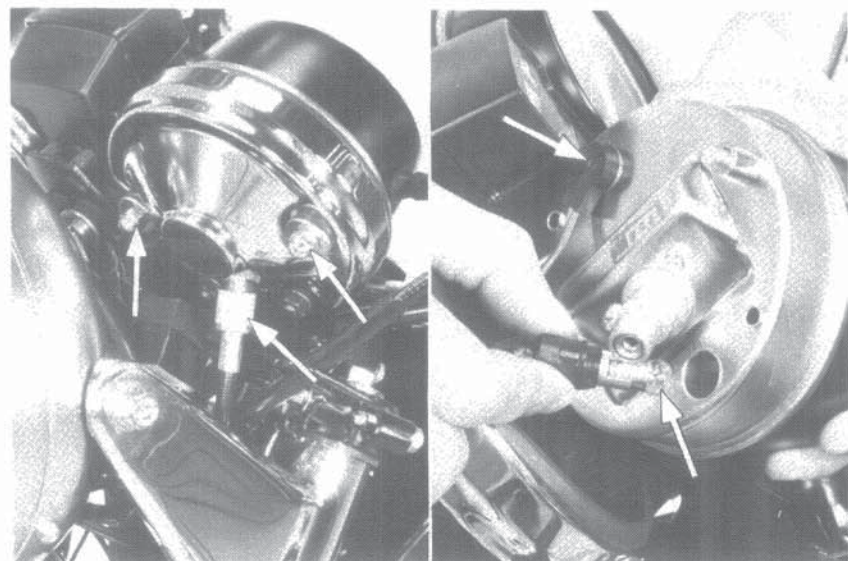
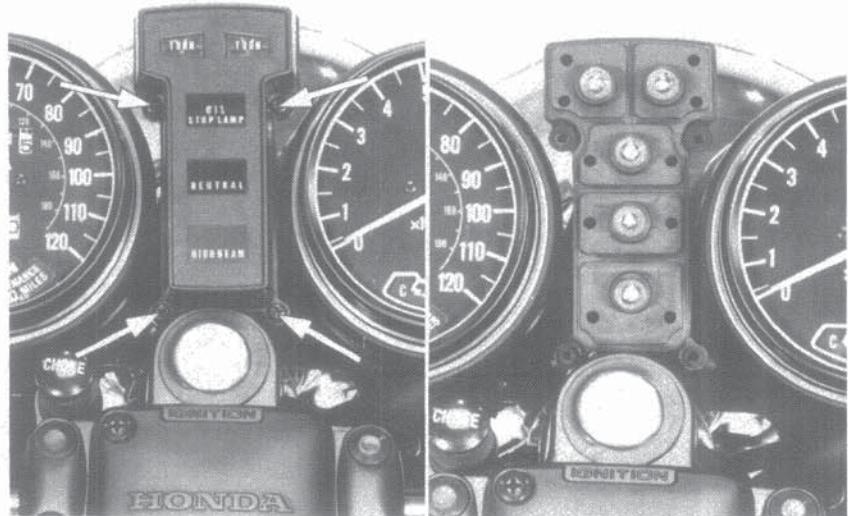





• INSTRUMENT REMOVAL

Remove the headlight.  
Disconnect the instrument wire connectors and coupler.  
Remove the speedometer and tachometer cables from the instruments.



Remove the instrument mounting bolts and instruments.

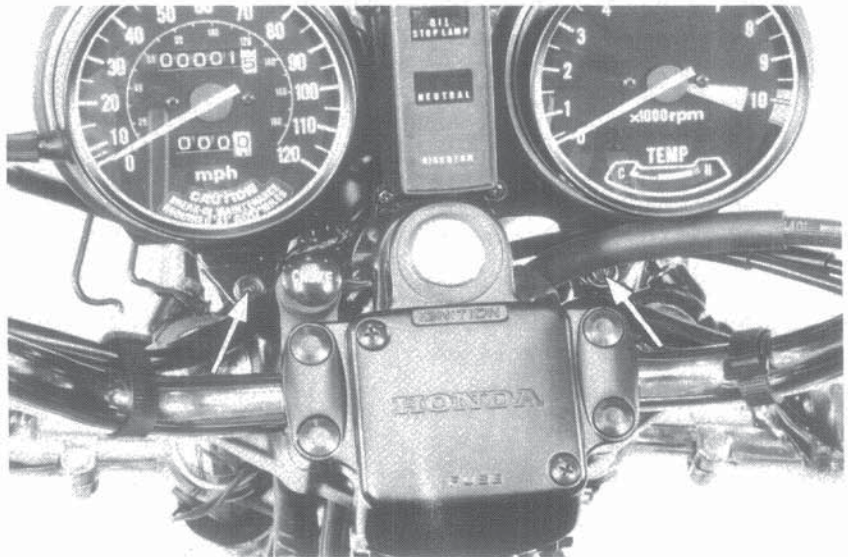



## CUSTOM : REAR SHOCK ABSORBER

### ● REMOVAL

Loosen the muffler clamp bolts and remove the muffler mounting bolts.  
Remove the mufflers.

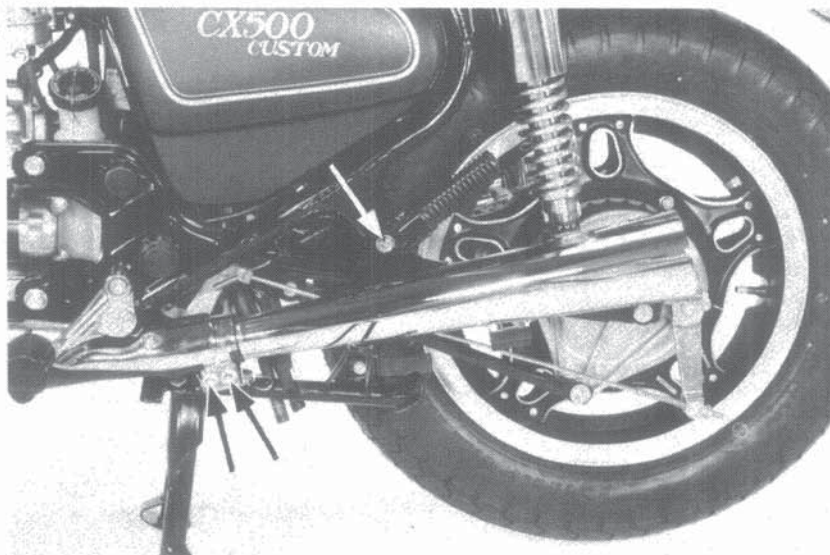

Remove the grab rail attaching bolts.  
Remove the upper and lower shock absorber mounting bolts and nuts.  
Remove the shock absorbers.

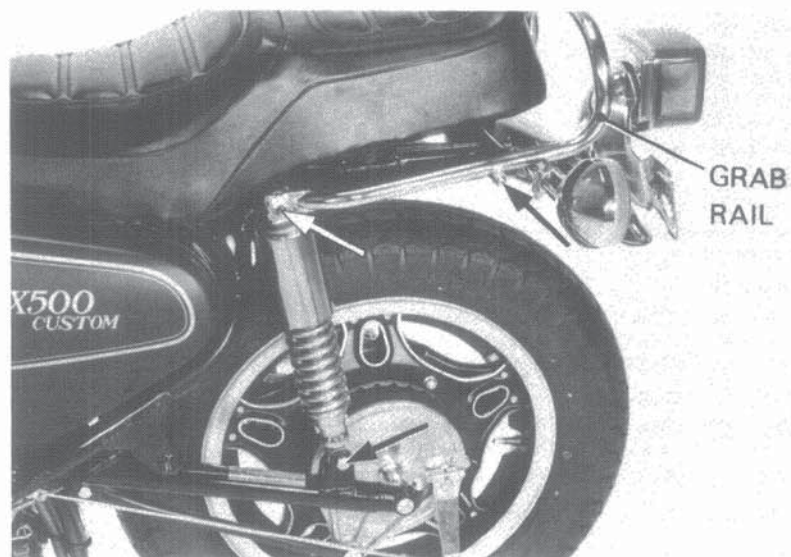

### ● INSTALLATION

Tighten the shock absorber bolts and nuts.

**TORQUE: 3.0–4.0 kg-m (22–29 ft-lb)**

Install the mufflers.

Adjust the right and left shock absorbers equally with a spanner wrench.

Check the shock absorber operation after installation.





## CUSTOM : OIL PRESSURE/ STOP LAMP WARNING INDICATOR

### ● SYSTEM TEST

Turn the ignition switch ON.  
The OIL/STOP LAMP warning indicator should go on.  
If it does not, follow the troubleshooting guide below to determine the cause.

#### Troubleshooting

1. Burnt out warning indicator
2. Open oil pressure circuit (Blue/Red wire)
3. Burnt out fuse
4. Faulty oil pressure switch

Start the engine.

The OIL/STOP LAMP warning indicator should go off.

If it does not, follow the troubleshooting guide below to determine the cause.

#### Troubleshooting

##### Engine Oil System

1. Oil level low
2. Faulty oil pressure switch
3. Plugged oil pick-up screen
4. Pressure relief valve stuck open
5. Oil pump worn or faulty
6. Oil pump drive sprocket or chain broken
7. Internal oil leakage

##### Brakelight

1. Burnt out bulb
2. Poor wire or socket connections
3. Open circuit

##### Wire Harness

1. Poor wire connections
2. Open circuit
3. Short circuit (Blue/Red to Green)

##### Stop Lamp Warning Unit

1. Internal open circuit (Green/Yellow and Green)
2. Internal short circuit (Blue/Red and Green)

### ● STOP LAMP WARNING UNIT TEST

Disconnect the warning unit coupler and remove the unit.

Connect the unit Black/Brown wire to the positive terminal of a 12V battery.

Connect the Green wire to the negative terminal.

Connect a 12V-3.4W test lamp between the Black/Brown and Blue/Red wire terminals.

Jump the Green/Yellow wire terminal to the Green wire terminal. The test lamp should go off.

Disconnect the Black/Brown wire from the battery.

The test lamp should go on. If connecting the Green/Yellow wire and then reconnecting the Black/Brown wire to positive terminal, the test lamp does not go on.

Disconnect Green/Yellow wire from the Green wire. The test lamp should go on.

Reconnect the Green/Yellow wire to the Green wire. The test lamp should stay on.

Replace the unit if it does not pass the above test.

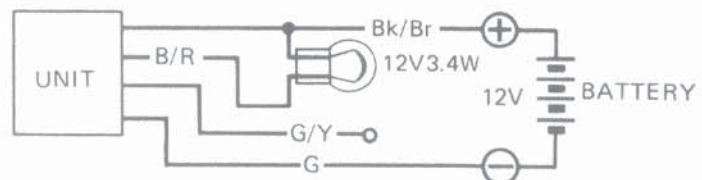
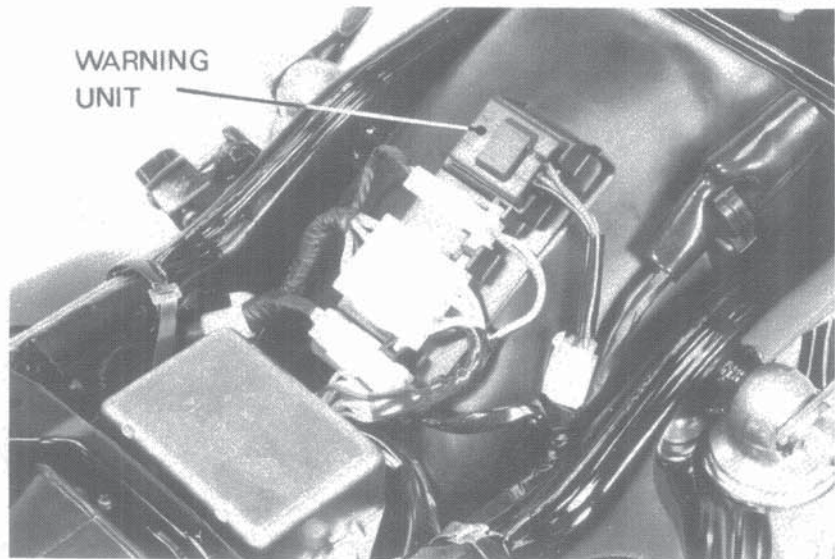
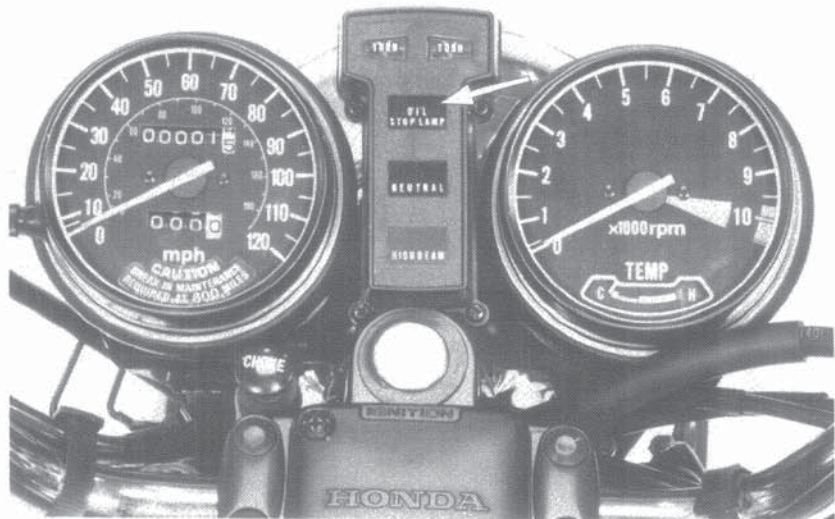



## INTRODUCTION

This Honda Shop Manual addendum contains information for the 1980 CX500 DELUXE and CX500 CUSTOM.

Refer to the base Shop Manual for service procedures and data not included in this addendum.

ALL INFORMATION, ILLUSTRATIONS, DIRECTIONS AND SPECIFICATIONS INCLUDED IN THIS PUBLICATION ARE BASED ON THE LATEST PRODUCT INFORMATION AVAILABLE AT THE TIME OF APPROVAL FOR PRINTING. HONDA MOTOR CO., LTD. RESERVES THE RIGHT TO MAKE CHANGES AT ANY TIME WITHOUT NOTICE AND WITHOUT INCURRING ANY OBLIGATION WHATEVER. NO PART OF THIS PUBLICATION MAY BE REPRODUCED WITHOUT WRITTEN PERMISSION.

HONDA MOTOR CO., LTD.  
Service Publications Office

## TABLE OF CONTENTS

1. GENERAL INFORMATION .....	23- 2
SPECIFICATIONS .....	23- 2
MAINTENANCE SCHEDULE .....	23- 4
CABLE & HARNESS ROUTING ....	23- 5
2. LUBRICATION .....	23- 6
ENGINE OIL LUBRICATION .....	23- 6
CABLE LUBRICATION .....	23- 6
3. INSPECTION AND ADJUSTMENT ..	23- 6
SPARK PLUG .....	23- 6
4. FUEL SYSTEM .....	23- 7
CARBURETOR SPECIFICATIONS ..	23- 7
SEPARATION AND ASSEMBLY ...	23- 7
ACCELERATOR PUMP	
INSPECTION .....	23- 8
ACCELERATOR PUMP	
ADJUSTMENT .....	23- 8
PILOT SCREW REMOVAL/ INSTALLATION .....	23- 9
PILOT SCREW ADJUSTMENT .....	23- 9
IDLE LIMITER INSTALLATION ...	23-10
5. WIRING DIAGRAM .....	23-11





# 1. GENERAL INFORMATION

## SPECIFICATIONS

ITEM		SPECIFICATIONS		
		CX500 DELUXE	CX500 CUSTOM	
DIMENSIONS	Overall length	2,185 mm (86.0 in)	2,150 mm (84.6 in)	
	Overall width	865 mm (34.1 in)	875 mm (34.4 in)	
	Overall height	1,165 mm (45.9 in)	1,170 mm (46.1 in)	
	Wheelbase	1,455 mm (57.3 in)	1,455 mm (57.3 in)	
	Seat height	800 mm (31.5 in)	790 mm (31.1 in)	
	Foot peg height	335 mm (13.2 in)	325 mm (12.8 in)	
	Ground clearance	145 mm ( 5.7 in)	145 mm ( 5.7 in)	
	Dry weight	205 kg (452 lb)	202 kg (445 lb)	
FRAME	Type	Diamond		
	Front suspension, travel	Telescopic fork, 139.5 mm (5.5 in)		
	Rear suspension, travel	Swingarm, 85 mm (3.3 in)		
	Front tire size	3.50S19-4PR		
	Rear tire size	130/90-16 67S		
	Cold tire pressures	Up to 90 kg (200 lbs) load	Front Rear	2.0 kg/cm <sup>2</sup> (28 psi) 2.0 kg/cm <sup>2</sup> (28 psi)
Up to vehicle capacity load		Front Rear	2.0 kg/cm <sup>2</sup> (28 psi) 2.25kg/cm <sup>2</sup> (32 psi)	
	Front brake, lining swept area	Disc brake, 600 cm <sup>2</sup> (93.0 sq in)		
	Rear brake, lining swept area	Internal expanding shoes, 201 cm <sup>2</sup> (31.2 sq in)		
	Fuel capacity	17 liters (4.5 US gal) 3.5 liters (0.9 US gal)	11 liters (2.9 US gal) 2.5 liters (0.7 US gal)	
	Caster angle	63° 15'		
	Trail	105 mm (3.9 in)		
	Front fork oil capacity	135 cc (4.7 ozs) After assembly		
ENGINE	Type	Liquid cooled 4-stroke OHV		
	Cylinder arrangement	2 cylinder transverse V		
	Bore and stroke	78 x 52 mm (3.07 x 2.04 in)		
	Displacement	496 cc (30.3 cu in)		
	Compression ratio	10 : 1		
	Valve train	Silent chain driven camshaft and push rod		
	Oil capacity	3.0 liters (3.2 US qt)		
	Lubrication system	Forced pressure and wet sump		
	Cooling system capacity	2.0 liters (0.52 US gal)		
	Air filtration	Paper		
	Cylinder compression	12 kg/cm <sup>2</sup> (171 psi)		
	Intake valve	Opens Closes	6° BTDC (at 1 mm lift), 79° BTDC (at 0 lift) 46° ABDC (at 1 mm lift), 123° ABDC (at 0 lift)	
	Exhaust	Opens Closes	46° BBDC (at 1 mm lift), 114° BBDC (at 0 lift) 6° ATDC (at 1 mm lift), 85° ATDC (at 0 lift)	
	Valve clearance	IN: 0.08 mm (0.003 in) EX: 0.10 mm (0.004 in)		
	Engine weight	65 kg (143.3 lb)		
Idle speed	1,100 ± 100 rpm			



ITEM		SPECIFICATIONS																																	
		CX500 DELUXE			CX500 CUSTOM																														
CARBURETION	Carburetor type	CV 34 mm (1.3 in)																																	
	Identification number	VB28A			VB25A																														
	Pilot screw Float level	See page 23-9 15.5 ± 1 mm (0.61 ± 0.04 in)																																	
DRIVE TRAIN	Clutch	Wet, multi-plate																																	
	Transmission	5-speed, constant-mesh																																	
	Primary reduction	2.242																																	
	Gear ratio I	2.733																																	
	Gear ratio II	1.850																																	
	Gear ratio III	1.416																																	
	Gear ratio IV	1.148																																	
	Gear ratio V	0.931																																	
	Final reduction Gear shift pattern	3.091 (11/34) Left foot operated return system 1-N-2-3-4-5																																	
ELECTRICAL	Ignition	CDI																																	
	Ignition timing "F" mark	15° BTDC/1,100 ± 100 rpm																																	
	Full advance	37° ± 3° BTDC																																	
	RPM from "F" to full advance	1,750-6,000 rpm																																	
	Starting system	Starting motor only																																	
	Generator	Three phase A.C. generator 170W/5,000 rpm																																	
	Battery capacity	12V-14AH																																	
	Spark plug	<table border="1" style="width:100%; border-collapse: collapse;"> <thead> <tr> <th></th> <th colspan="2">For cold climate below 5°C (41°F)</th> <th colspan="2">Standard</th> <th colspan="2">For extended high speed riding</th> </tr> <tr> <th></th> <th>ND</th> <th>NGK</th> <th>ND</th> <th>NGK</th> <th>ND</th> <th>NGK</th> </tr> </thead> <tbody> <tr> <td>USA model</td> <td>X22ES-U</td> <td>D7EA</td> <td>X24ES-U</td> <td>D8EA</td> <td>X27ES-U</td> <td>D9EA</td> </tr> <tr> <td>Canadian model</td> <td>X22ESR -U</td> <td>DR7ES</td> <td>X24ESR -U</td> <td>DR8ES -L</td> <td>X27ESR -U</td> <td>DR8ES</td> </tr> </tbody> </table>							For cold climate below 5°C (41°F)		Standard		For extended high speed riding			ND	NGK	ND	NGK	ND	NGK	USA model	X22ES-U	D7EA	X24ES-U	D8EA	X27ES-U	D9EA	Canadian model	X22ESR -U	DR7ES	X24ESR -U	DR8ES -L	X27ESR -U	DR8ES
		For cold climate below 5°C (41°F)		Standard		For extended high speed riding																													
		ND	NGK	ND	NGK	ND	NGK																												
USA model	X22ES-U	D7EA	X24ES-U	D8EA	X27ES-U	D9EA																													
Canadian model	X22ESR -U	DR7ES	X24ESR -U	DR8ES -L	X27ESR -U	DR8ES																													
Spark plug gap	0.6-0.7 mm (0.024-0.028 in)																																		
Fuse	20A (main), 10A (sub)																																		
LIGHTS	Headlight (high/low beam)	65/50W sealed beam																																	
	Tail/stoplight	8/27W (3/32 cp SAE NO. 1157)																																	
	Turn signal light (front/rear)	23/23W (32/32 cp SAE NO. F. 1034, R. 1073)																																	
	Speedometer light	3.4W (2 cp SAE NO. 57)																																	
	Tachometer light	3.4W (2 cp SAE NO. 57)																																	
	Neutral indicator	3.4W (2 cp SAE NO. 57)																																	
	Turn signal indicator	3.4W (2 cp SAE NO. 57)																																	
	High beam indicator	3.4W (2 cp SAE NO. 57)																																	
	Running light	8W (3 cp SAE NO. 1034)																																	





## MAINTENANCE SCHEDULE DELUXE AND CUSTOM

Perform the PRE-RIDE INSPECTION in the Owner's Manual at each scheduled maintenance.

I: INSPECT AND CLEAN, ADJUST, LUBRICATE OR REPLACE IF NECESSARY.

C: CLEAN

R: REPLACE

A: ADJUST

L: LUBRICATE

ITEM	FREQUENCY	WHICHEVER COMES FIRST ↓ EVERY	ODOMETER READING [NOTE 3]							REFER TO
			600 mi. (1,000 km)	3,750 mi. (6,000 km)	7,500 mi. (12,000 km)	11,250 mi. (18,000 km)	15,000 mi. (24,000 km)	18,750 mi. (30,000 km)	22,500 mi. (36,000 km)	
EMISSION RELATED ITEMS	* FUEL LINES				I		I		I	Page 3- 3
	* THROTTLE OPERATION		I		I		I		I	Page 3- 5
	* CARBURETOR-CHOKE				I		I		I	Page 3- 6
	AIR CLEANER	NOTE 1		C	R	C	R	C	R	Page 3- 2
	CRANKCASE BREATHER	NOTE 2		C	C	C	C	C	C	Page 3- 3
	SPARK PLUGS			R	R	R	R	R	R	Page 23- 6
	* VALVE CLEARANCE		I	I	I		I		I	Page 3- 4
	ENGINE OIL	YEAR	R		R		R		R	Page 2- 2 23- 6
	ENGINE OIL FILTER	YEAR	R		R		R		R	Page 2- 2
	* CAM CHAIN TENSION		A	A	A	A	A	A	A	Page 3- 5
	* CARBURETOR-SYNCHRONIZE		I		I		I		I	Page 3- 7
	* CARBURETOR-IDLE SPEED		I	I	I	I	I	I	I	Page 3- 6
	* RADIATOR COOLANT				I		I		R	Page 3- 8 9- 3
	* RADIATOR CORE				I		I		I	Page 3- 8
	* COOLING SYSTEM, HOSES & CONNECTIONS		I		I		I		I	Page 3- 8
NON-EMISSION RELATED ITEMS	* DRIVE SHAFT JOINT				L		L		L	Page 2- 3
	* FINAL DRIVE LUBRICANT				I		I		R	Page 2- 3
	BATTERY	MONTH	I	I	I	I	I	I	I	Page 3- 9
	BRAKE FLUID ( FRONT)	MONTH 2 YEARS *R	I	I	I	I	I	I	*R	Page 3- 9
	BRAKE SHOE/PAD WEAR			I	I	I	I	I	I	Page 3-11
	BRAKE SYSTEM (REAR)			I	I	I	I	I	I	Page 3-11
	* BRAKE LIGHT SWITCH			I	I	I	I	I	I	Page 3-12
	* HEADLIGHT AIM			I	I	I	I	I	I	Page 3-13
	CLUTCH			I	I	I	I	I	I	Page 3-13
	SIDE STAND				I	I	I	I	I	Page 3-14
	* SUSPENSION			I	I	I	I	I	I	Page 3-14
	* NUTS, BOLTS, FASTENERS			I	I	I	I	I	I	Page 3-15
** WHEELS			I	I	I	I	I	I	Page 3-15	
** STEERING HEAD BEARING			I	I	I	I	I	I	Page 3-15	

\* SHOULD BE SERVICED BY AN AUTHORIZED HONDA DEALER, UNLESS THE OWNER HAS PROPER TOOLS AND SERVICE DATA AND IS MECHANICALLY QUALIFIED.

\*\* IN THE INTEREST OF SAFETY, WE RECOMMEND THESE ITEMS BE SERVICED ONLY BY AN AUTHORIZED HONDA DEALER.

- NOTE:
1. Service more frequently when riding in dusty areas.
  2. Service more frequently when riding in rain or at full throttle, or after being washed or overturned.
  3. For higher odometer readings, repeat at the frequency interval established here.



**CABLE & HARNESS ROUTING**

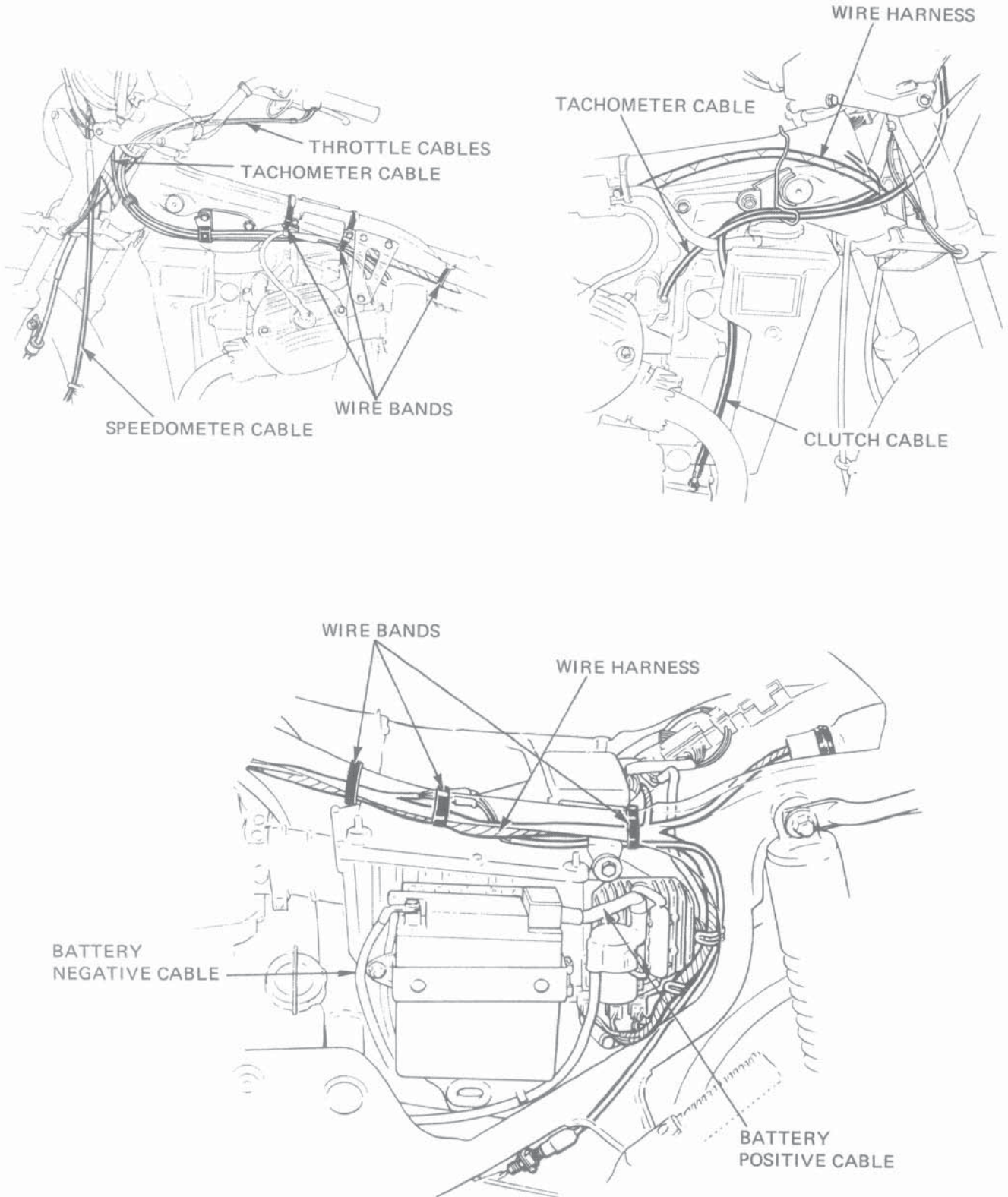





## 2. LUBRICATION

### ENGINE OIL RECOMMENDATION

Use HONDA 4-STROKE OIL or equivalent.

API SERVICE CLASSIFICATION: SE

VISCOSITY: SAE 10W-40

Other viscosities shown in the chart may be used when the average temperature in your riding area is within the indicated range

OIL VISCOSITIES

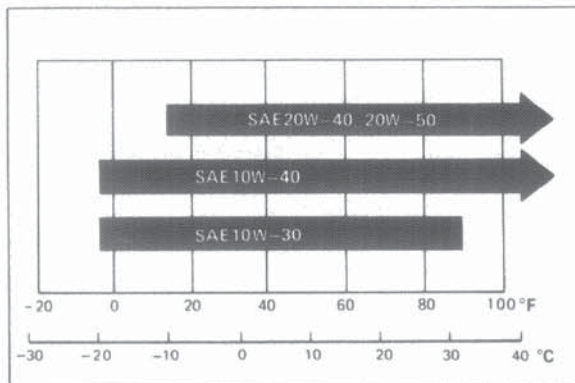

### CABLE LUBRICATION

Lubricate the clutch, choke and throttle cables with a commercially available cable lubricant to prevent premature wear and corrosion.

## 3. INSPECTION AND ADJUSTMENT

### SPARK PLUG

Disconnect the spark plug caps.

Clean any dirt from around the spark plug base.

Remove and discard the spark plugs.

Check the new spark plug gaps with a wire type feeler gauge.

If adjustment is necessary, bend the side electrode carefully.

#### SPARK PLUG GAP:

0.6-0.7 mm (0.024-0.028 in)

With the plug washers attached, thread the new spark plugs in by hand to prevent cross-threading.

Tighten the spark plugs 1/2 turn with a spark plug wrench.

Install the spark plug caps.

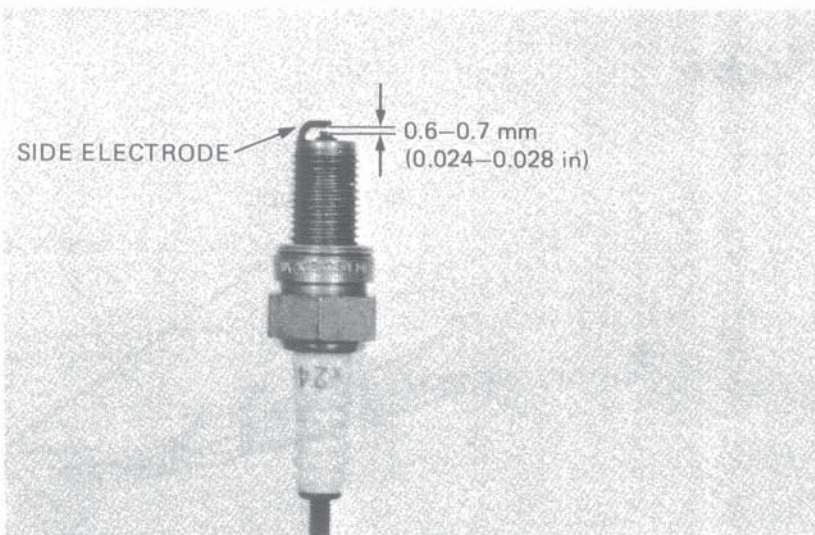

#### RECOMMENDED SPARK PLUG:

	For cold climate below 5°C (41°F)		Standard		For extended high speed riding	
	ND	NGK	ND	NGK	ND	NGK
USA model	X22ES-U	D7EA	X24ES-U	D8EA	X27ES-U	D9EA
Canadian model	X22ESR-U	DR7ES	X24ESR-U	DR8ES-L	X27ESR-U	DR8ES



## 4. FUEL SYSTEM

### GENERAL INFORMATION

- The CX500 carburetor bore size has been changed to 34 mm (1.3 in).
- An accelerator pump circuit has been added.
- See Caution and Note under Pilot Screw Removal and Pilot Screw Adjustment (Page 23-10).

### CARBURETOR SPECIFICATIONS

	CX500 DELUXE	CX500 CUSTOM
Identification mark	VB28A	VB25A
Idle speed	1,100 ± 100 rpm	←
Fast idle speed	1,000 – 1,500 rpm	←
Float level	15.5 ± 1 mm	←
Pilot screw	See page 23-9	←
Bore	34 mm	←
Main jet	Primary #78	←
	Secondary #115	←

### CARBURETOR SEPARATION

Remove the carburetors (Page 4-2).  
Separate the carburetors (Page 4-3), noting that the accelerator pump joint pipe must be removed.

### ASSEMBLY

Install a new O-ring on each end of the accelerator pump and fuel joint pipes.  
Assemble the right and left carburetors noting the compression spring location.  
Install the front and rear stays.  
Refer to page 4-9 for carburetor installation.

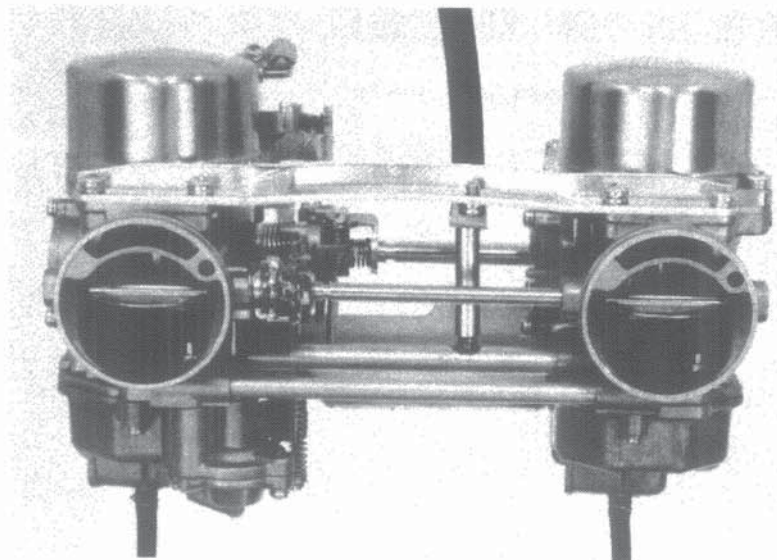





## ACCELERATOR PUMP INSPECTION

Remove the accelerator pump by unscrewing the setting screw.

Remove the accelerator pump cover and spring.

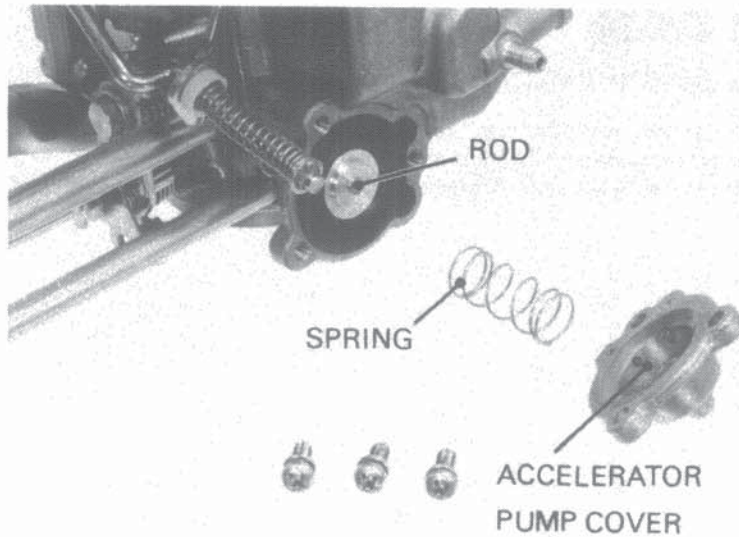

Remove the diaphragm.  
Inspect the diaphragm for cracks and brittleness.  
Replace if necessary.  
Be sure the accelerator rod is not bent.

Assemble the accelerator pump in the reverse order of disassembly.

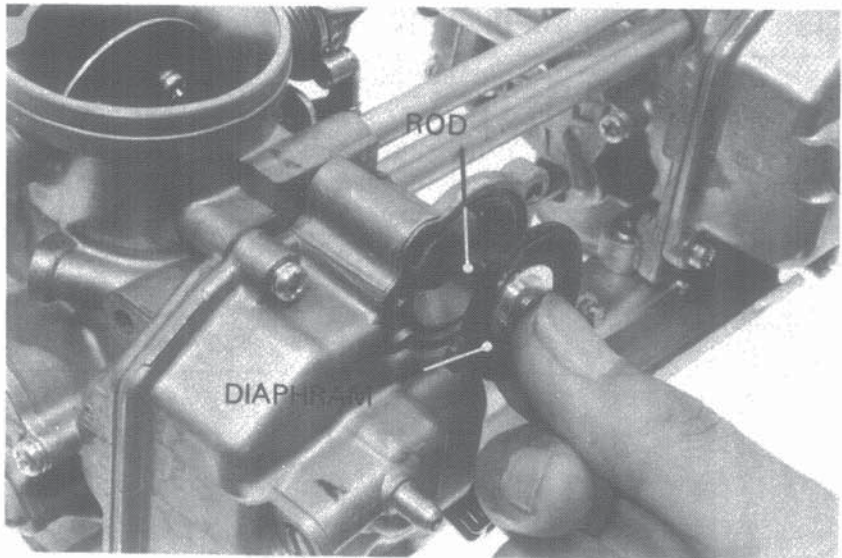

## ACCELERATOR PUMP ADJUSTMENT

Loosen the throttle stop screw, so the throttle valve is closed.

Measure the clearance between the accelerator pump rod and the adjusting arm with the throttle valve closed.

**CLEARANCE:** 0.1–0.3 mm  
(0.004–0.012 in)

Adjust by bending the adjusting arm.

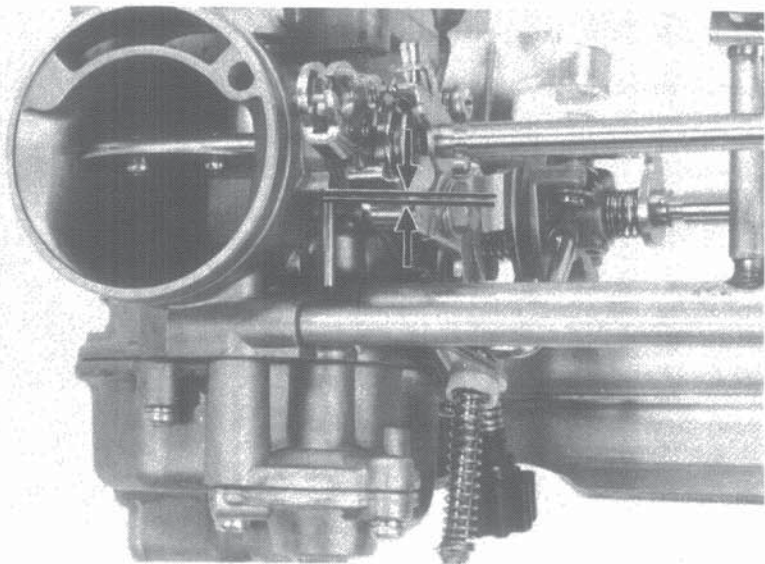





Measure the clearance between the adjusting arm and stopper on the carburetor.

**CLEARANCE:** 3.1–3.3 mm (0.12–0.13 in)

Adjust by bending the adjusting arm.

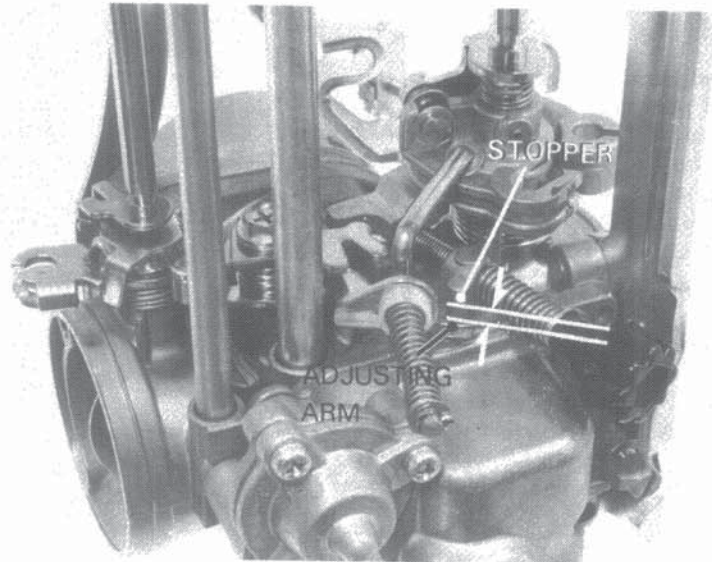

## PILOT SCREW REMOVAL/ INSTALLATION

### NOTE

The pilot screws are factory pre-set and should not be removed unless the carburetors are overhauled.

### CAUTION

*Any forcible attempt to remove the pilot screw limiter caps will cause screw breakage.*

Remove the carburetors (page 4-2).  
Remove the float chamber (page 4-6).

Turn the pilot screw in and carefully count the number of turns before it seats lightly. Make a note of this to use as a reference when reinstalling the pilot screws.

### CAUTION

*Damage to the pilot screw seat will occur if the pilot screw is tightened against the seat.*

Remove the pilot screw.  
Inspect the pilot screw for wear and replace if necessary.  
Install the pilot screw and turn it to the original position, as noted during removal. Perform pilot screw adjustment if a new pilot screw is installed. (See below)

### NOTE

Do not install limiter caps on new pilot screws until after adjustment has been made (See page 23-11).

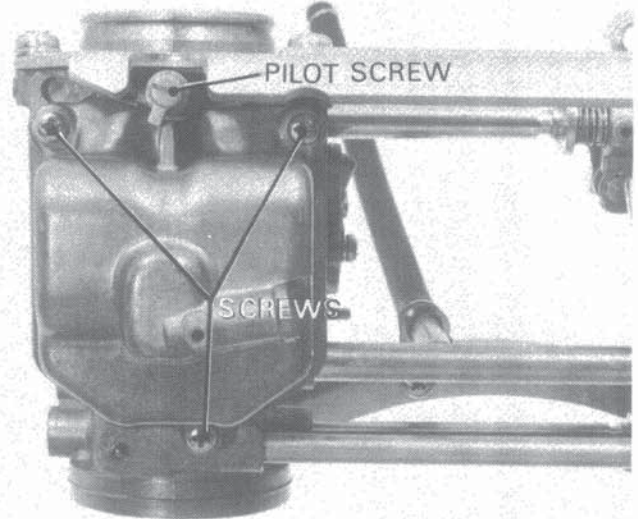

## PILOT SCREW ADJUSTMENT

Adjust the pilot screws (page 4-10), using 1-3/4 turns as the pilot screw initial opening.

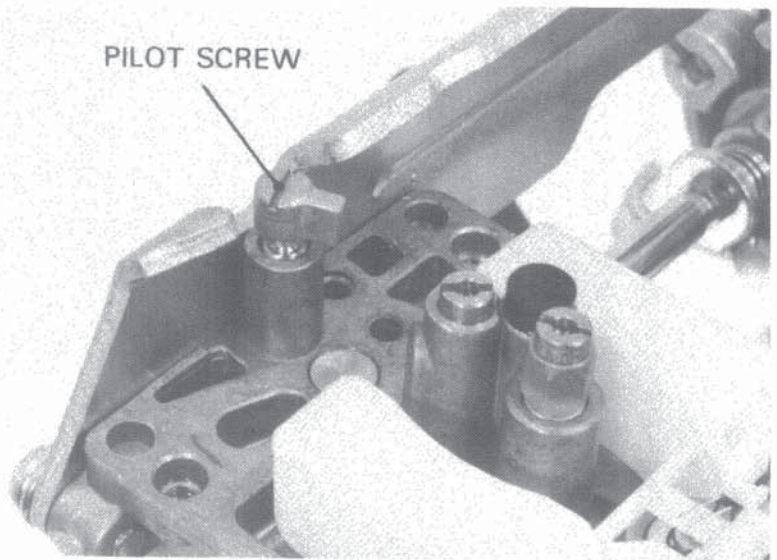





## IDLE LIMITER INSTALLATION

After adjustment, cement the limiter caps over the pilot screws, using LOCTITE® #601 or equivalent. The limiter cap should be placed against its stop, preventing further adjustment that would enrich the fuel mixture (limiter cap position permits clockwise rotation and prevents counterclockwise rotation).

### NOTE

- Do not turn the pilot screws when installing the limiter caps.
- Pilot screw limiter caps must be installed. They prevent misadjustment that could cause poor performance and increase exhaust emissions.

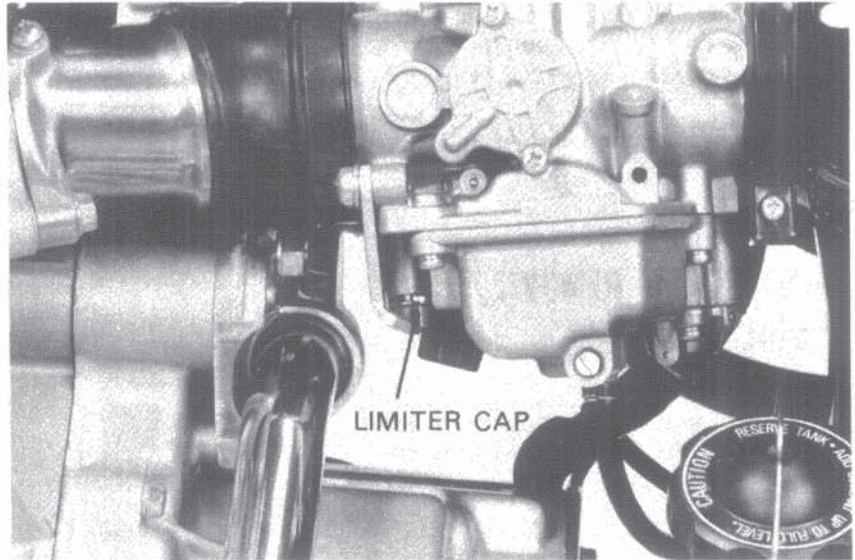



CX500

'80 ADDENDUM

# 5. WIRING DIAGRAM CX500 DELUXE

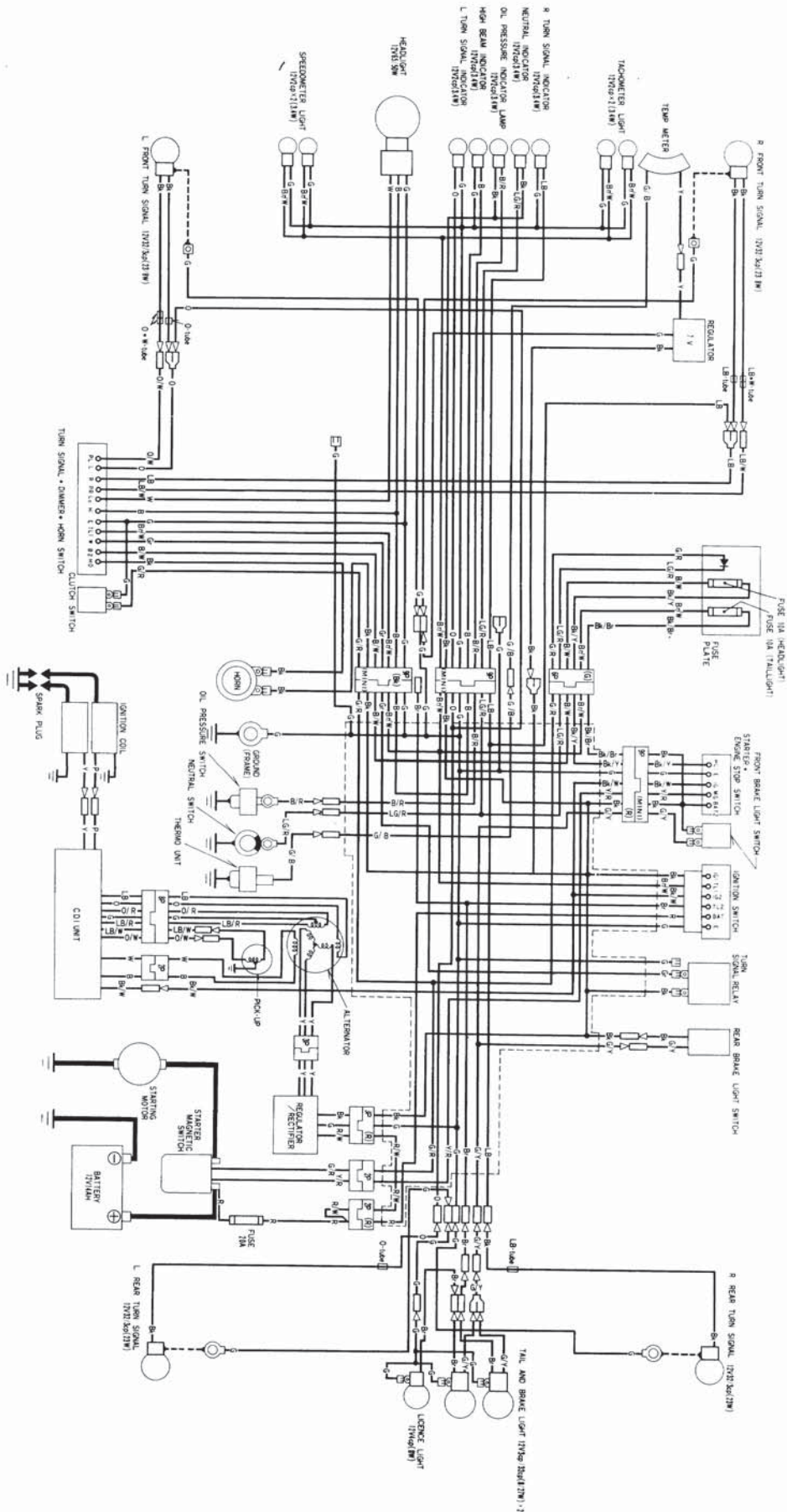

IGNITION SWITCH CONTINUITY

	E	IG	BAT	IG	TL	TL2
OFF	○	○	○	○	○	○
ON	○	○	○	○	○	○
P	○	○	○	○	○	○
LOCK	○	○	○	○	○	○

STARTER ENGINE STOP SWITCH CONTINUITY

	IG	E	STARTER SWITCH	MAG	BAT2	HL
OFF	○	○	○	○	○	○
ON	○	○	○	○	○	○
RAM	○	○	○	○	○	○
OFF	○	○	○	○	○	○

TURN SIGNAL, DIMMER + HORN SWITCH CONTINUITY

	R2	L1	H	NO	E	TURN SIGNAL SWITCH
OFF	○	○	○	○	○	○
ON	○	○	○	○	○	○
RAM	○	○	○	○	○	○
OFF	○	○	○	○	○	○

TURN SIGNAL SWITCH CONTINUITY

	R	L	TL	FR	PL
OFF	○	○	○	○	○
ON	○	○	○	○	○
RAM	○	○	○	○	○
OFF	○	○	○	○	○

Legend for Wire Colors:

B	Blue	Y	Yellow
Bl	Black	B	Brown
Wh	White	G	Grey
Lc	Light Green	LB	Light Blue
Rd	Red	Or	Orange
G	Green	P	Pink

0030Z-470-6700



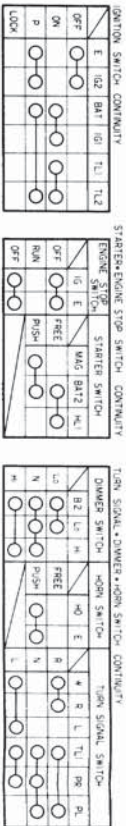
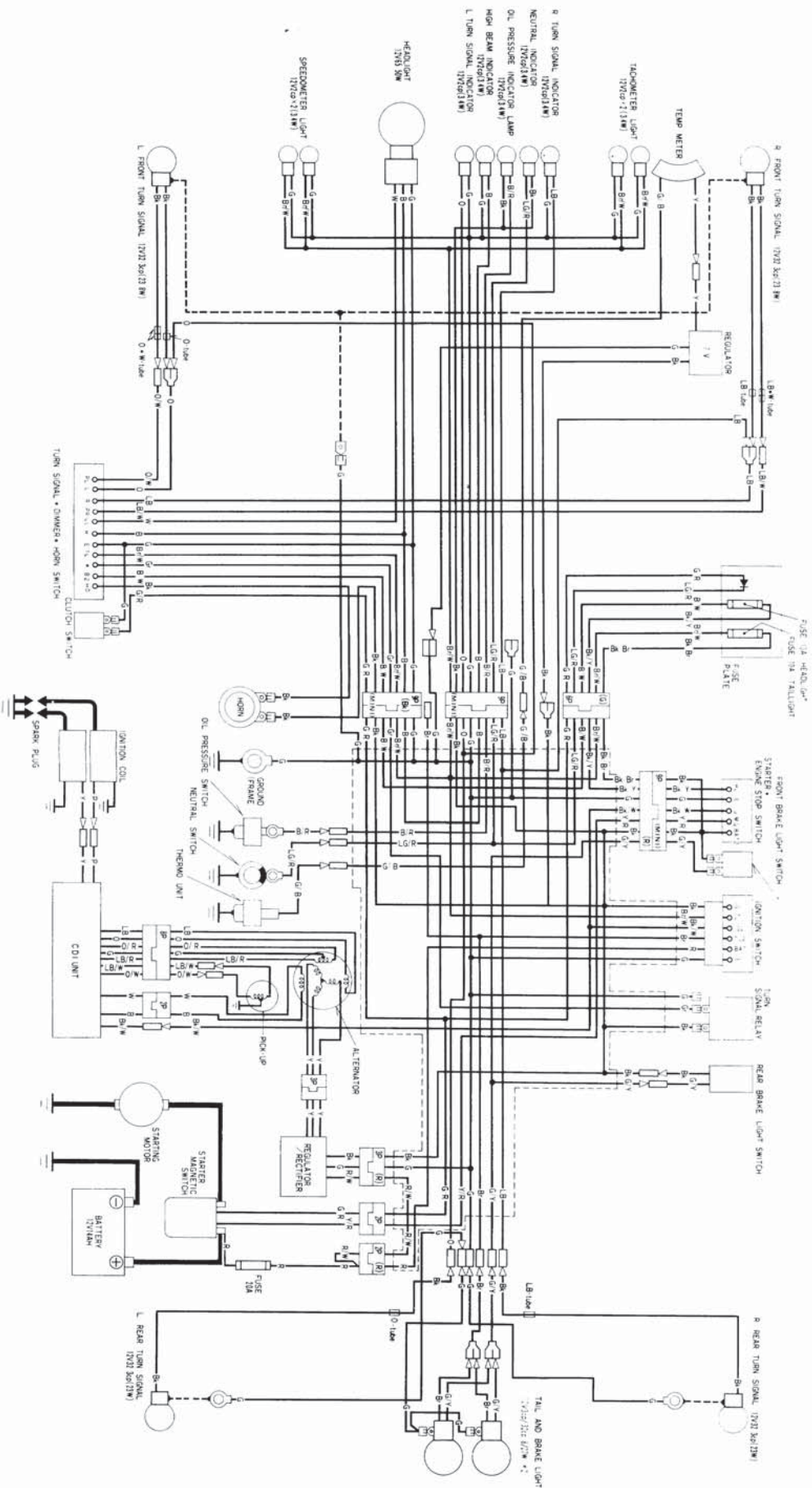

B	Brn	Y	Yel
Bk	Blk	B	Blu
W	Wh	G	Grn
L5	Lgt Grn	LB	Lgt Blu
R	Rd	O	Orn
G	Grn	P	Pk

0030Z-449-7700



## INTRODUCTION

This Honda Shop Manual addendum contains information for the 1981 CX500 DELUXE and CX500 CUSTOM. Refer to the base Shop Manual for service procedures and data not included in this addendum.

ALL INFORMATION, ILLUSTRATIONS, DIRECTIONS AND SPECIFICATIONS INCLUDED IN THIS PUBLICATION ARE BASED ON THE LATEST PRODUCT INFORMATION AVAILABLE AT THE TIME OF APPROVAL FOR PRINTING. HONDA MOTOR CO., LTD. RESERVES THE RIGHT TO MAKE CHANGES AT ANY TIME WITHOUT NOTICE AND WITHOUT INCURRING ANY OBLIGATION WHATEVER. NO PART OF THIS PUBLICATION MAY BE REPRODUCED WITHOUT WRITTEN PERMISSION.

HONDA MOTOR CO., LTD.  
Service Publications Office

## TABLE OF CONTENTS

1. GENERAL INFORMATION .....	24- 2
SPECIFICATIONS .....	24- 2
MAINTENANCE SCHEDULE .....	24- 4
CABLE & HARNESS ROUTING ....	24- 5
2. INSPECTION AND ADJUSTMENT ..	24- 6
FUEL LINE .....	24- 6
CARBURETOR SYNCHRONIZATION	24- 6
3. FUEL SYSTEM .....	24- 7
SPECIFICATIONS .....	24- 7
FUEL LINE DIAPHRAGM .....	24- 8
4. FRONT WHEEL/SUSPENSION .....	24-11
FRONT WHEEL .....	24-12
FRONT FORKS .....	24-13
5. SWITCHES .....	24-21
IGNITION SWITCH .....	24-21
6. WIRING DIAGRAMS .....	24-23





# 1. GENERAL INFORMATION

## SPECIFICATIONS

ITEM		SPECIFICATIONS		
		CX500 DELUXE	CX500 CUSTOM	
DIMENSIONS	Overall length	2,185 mm (86.0 in)	2,160 mm (85.0 in)	
	Overall width	865 mm (34.1 in)	885 mm (34.8 in)	
	Overall height	1,165 mm (45.9 in)	1,170 mm (46.1 in)	
	Wheelbase	1,455 mm (57.3 in)	1,460 mm (57.5 in)	
	Seat height	800 mm (31.5 in)	795 mm (31.3 in)	
	Foot peg height	335 mm (13.2 in)	330 mm (13.0 in)	
	Ground clearance	145 mm ( 5.7 in)	145 mm ( 5.7 in)	
	Dry weight	205 kg (452 lb)	202 kg (445 lb)	
FRAME	Type	Diamond		
	Front suspension, travel	Telescopic fork, 140.0 mm (5.5 in)		
	Rear suspension, travel	Swingarm, 85 mm (3.3 in)		
	Front tire size	3.50S19-4PR		
	Rear tire size	130/90-16 67S		
	Cold tire pressures	Up to 90 kg (200 lbs) load	Front Rear	2.0 kg/cm <sup>2</sup> (28 psi) 2.0 kg/cm <sup>2</sup> (28 psi)
		Up to vehicle capacity load	Front Rear	2.0 kg/cm <sup>2</sup> (28 psi) 2.25 kg/cm <sup>2</sup> (32 psi)
	Front brake, lining swept area		Disc brake, 600 cm <sup>2</sup> (93.0 sq in)	
Rear brake, lining swept area		Internal expanding shoes, 201 cm <sup>2</sup> (31.2 sq in)		
Fuel capacity		17 liters (4.5 US gal) 3.5 liters (0.9 US gal)	12 liters (3.2 US gal) 2.5 liters (0.7 US gal)	
Caster angle		63°15'	62°30'	
Trail		105 mm (3.9 in)	110 mm (4.3 in)	
Front fork oil capacity		185 cc (6.3 oz)	220 cc (7.5 oz)	
Front fork air pressure		0.7–1.1 kg/cm <sup>2</sup> (10–16 psi)		
ENGINE	Type	Liquid cooled 4-stroke OHV		
	Cylinder arrangement	2 cylinder transverse V		
	Bore and stroke	78 x 52 mm (3.07 x 2.04 in)		
	Displacement	497 cc (30.3 cu in)		
	Compression ratio	10 : 1		
	Valve train	Silent chain driven camshaft and push rod		
	Oil capacity	3.0 liters (3.2 US qt) after disassembly 2.5 liters (2.6 US qt) after draining		
	Lubrication system	Forced pressure and wet sump		
	Cooling system capacity	2.0 liters (0.52 US gal)		
	Air filtration	Paper		
	Cylinder compression	12 kg/cm <sup>2</sup> (171 psi)		
	Intake valve	Opens Closes	6° BTDC (at 1 mm lift), 79° BTDC (at 0 lift) 46° ABCD (at 1 mm lift), 123° ABDC (at 0 lift)	
	Exhaust	Opens Closes	46° BBDC (at 1 mm lift), 114° BBDC (at 0 lift) 6° ATDC (at 1 mm lift), 85° ATDC (at 0 lift)	
	Valve clearance	IN : 0.08 mm (0.003 in) EX: 0.10 mm (0.004 in)		
	Engine weight	65 kg (143.3 lb)		
Idle speed	1,100 ± 100 rpm			



# HONDA CX500

## '81 ADDENDUM

ITEM		SPECIFICATIONS																																	
		CX500 DELUXE			CX500 CUSTOM																														
CARBURETION	Carburetor type	CV 34 mm (1.3 in)																																	
	Identification number	VB28A			VB25A																														
	Pilot screw Float level	See page 23-9 15.5 ± 1 mm (0.61 ± 0.04 in)																																	
DRIVE TRAIN	Clutch	Wet, multi-plate																																	
	Transmission	5-speed, constant-mesh																																	
	Primary reduction	2.242																																	
	Gear ratio I	2.733																																	
	Gear ratio II	1.850																																	
	Gear ratio III	1.416																																	
	Gear ratio IV	1.148																																	
	Gear ratio V	0.931																																	
	Final reduction Gear shift pattern	3.091 (11/34) Left foot operated return system 1-N-2-3-4-5																																	
ELECTRICAL	Ignition	CDI																																	
	Ignition timing "F" mark	15° BTDC/1,100 ± 100 rpm																																	
	Full advance	37° ± 3° BTDC																																	
	RPM from "F" to full advance	1,750-6,000 rpm																																	
	Starting system	Starting motor only																																	
	Generator	Three phase A.C. generator 170W/5,000 rpm																																	
	Battery capacity	12V-14AH																																	
	Spark plug	<table border="1" style="width: 100%; border-collapse: collapse;"> <thead> <tr> <th></th> <th colspan="2">For cold climate below 5°C (41°F)</th> <th colspan="2">Standard</th> <th colspan="2">For extended high speed riding</th> </tr> <tr> <th></th> <th>ND</th> <th>NGK</th> <th>ND</th> <th>NGK</th> <th>ND</th> <th>NGK</th> </tr> </thead> <tbody> <tr> <td>USA model</td> <td>X22ES-U</td> <td>D7EA</td> <td>X24ES-U</td> <td>D8EA</td> <td>X27ES-U</td> <td>D9EA</td> </tr> <tr> <td>Canadian model</td> <td>X22ESR -U</td> <td>DR7ES</td> <td>X24ESR -U</td> <td>DR8ES -L</td> <td>X27ESR -U</td> <td>DR8ES</td> </tr> </tbody> </table>							For cold climate below 5°C (41°F)		Standard		For extended high speed riding			ND	NGK	ND	NGK	ND	NGK	USA model	X22ES-U	D7EA	X24ES-U	D8EA	X27ES-U	D9EA	Canadian model	X22ESR -U	DR7ES	X24ESR -U	DR8ES -L	X27ESR -U	DR8ES
		For cold climate below 5°C (41°F)		Standard		For extended high speed riding																													
		ND	NGK	ND	NGK	ND	NGK																												
USA model	X22ES-U	D7EA	X24ES-U	D8EA	X27ES-U	D9EA																													
Canadian model	X22ESR -U	DR7ES	X24ESR -U	DR8ES -L	X27ESR -U	DR8ES																													
Spark plug gap	0.6-0.7 mm (0.024-0.028 in)																																		
Fuse	30A (main), 10A (sub)																																		
LIGHTS	Headlight (high/low beam)	60/55W H4 Bulb (Phillips 12342/99 or equivalent)																																	
	Tail/stoplight	8/27W (3/32 cp SAE NO. 1157)																																	
	Turn signal light (front/rear)	23/23W (32/32 cp SAE NO. F. 1034, R. 1073)																																	
	Speedometer light	3.4W (2 cp SAE NO. 57)																																	
	Tachometer light	3.4W (2 cp SAE NO. 57)																																	
	Neutral indicator	3.4W (2 cp SAE NO. 57)																																	
	Turn signal indicator	3.4W (2 cp SAE NO. 57)																																	
	High beam indicator	3.4W (2 cp SAE NO. 57)																																	
	Running light	8W (3 cp SAE NO. 1034)																																	





# MAINTENANCE SCHEDULE

Perform the PRE-RIDE INSPECTION in the Owner's Manual at each scheduled maintenance.

I : INSPECT AND CLEAN, ADJUST, LUBRICATE OR REPLACE IF NECESSARY

C : CLEAN

R : REPLACE

A : ADJUST

L : LUBRICATE

FREQUENCY	WHICHEVER COMES FIRST ↓	ODOMETER READING [NOTE 3]								REFER TO PAGE		
		EVERY	600 mi. (1,000 km)	3,750 mi. (6,000 km)	7,500 mi. (12,000 km)	11,250 mi. (18,000 km)	15,000 mi. (24,000 km)	18,750 mi. (30,000 km)	22,500 mi. (36,000 km)			
ITEM												
EMISSION RELATED ITEMS	* FUEL LINES				I			I		I	3- 3	
	* THROTTLE OPERATION		I					I		I	3- 5	
	* CARBURETOR-CHOKE				I			I		I	3- 6	
	AIR CLEANER	NOTE 1		C	R	C	R	C	R	C	R	3- 2
	CRANKCASE BREATHER	NOTE 2		C	C	C	C	C	C	C	C	3- 3
	SPARK PLUGS			R	R	R	R	R	R	R	R	23- 6
	* VALVE CLEARANCE		I	I	I			I		I	I	3- 4
	ENGINE OIL	YEAR	R		R			R		R	R	2- 2
	ENGINE OIL FILTER	YEAR	R		R			R		R	R	2- 2
	* CAM CHAIN TENSION		A	A	A	A	A	A	A	A	A	3- 5
	* CARBURETOR-SYNCHRONIZE		I		I			I		I	I	24- 6
	* CARBURETOR-IDLE SPEED		I	I	I	I	I	I	I	I	I	3- 6
	RADIATOR COOLANT					I				R	R	3- 8 9- 3
	* RADIATOR CORE					I				I	I	3- 8
	* COOLING SYSTEM, HOSES & CONNECTIONS		I		I			I		I	I	3- 8
NON-EMISSION RELATED ITEMS	* DRIVE SHAFT JOINT				L			L		L	2- 3	
	FINAL DRIVE OIL				I			I		R	2- 3	
	BATTERY	MONTH	I	I	I	I	I	I	I	I	I	3- 9
	BRAKE FLUID ( FRONT )	MONTH   2 YEARS *R	I	I	I	I	I	I	I	*R	I	3- 9
	BRAKE SHOE/PAD WEAR			I	I	I	I	I	I	I	I	3-11
	BRAKE SYSTEM (REAR)		I		I			I		I	I	3-11
	* BRAKE LIGHT SWITCH		I		I			I		I	I	3-12
	* HEADLIGHT AIM		I		I			I		I	I	3-13
	CLUTCH		I	I	I	I	I	I	I	I	I	3-13
	SIDE STAND				I			I		I	I	3-14
	* SUSPENSION		I		I			I		I	I	3-14
	* NUTS, BOLTS, FASTENERS		I		I			I		I	I	3-15
** WHEELS		I		I			I		I	I	3-15	
** STEERING HEAD BEARING		I		I			I		I	I	3-15	

\* SHOULD BE SERVICED BY AN AUTHORIZED HONDA DEALER, UNLESS THE OWNER HAS PROPER TOOLS AND SERVICE DATA AND IS MECHANICALLY QUALIFIED.

\*\* IN THE INTEREST OF SAFETY, WE RECOMMEND THESE ITEMS BE SERVICED ONLY BY AN AUTHORIZED HONDA DEALER.

- NOTE:
1. Service more frequently when riding in dusty areas.
  2. Service more frequently when riding in rain or at full throttle, or after being washed or overturned.
  3. For higher odometer readings, repeat at the frequency interval established here.



**CABLE AND HARNESS ROUTING**

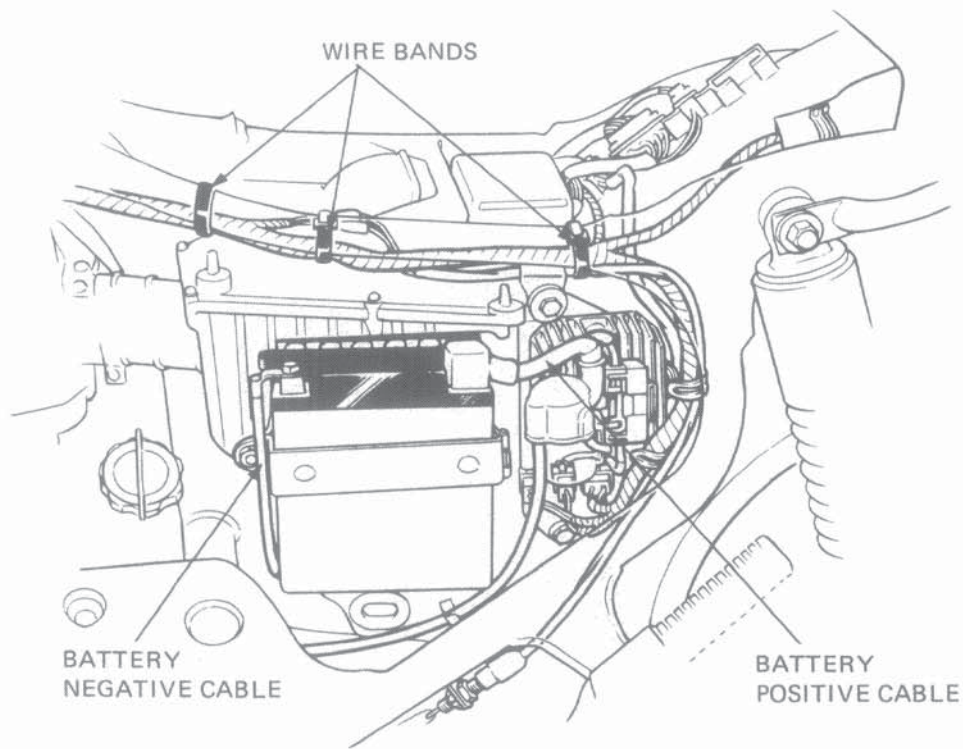
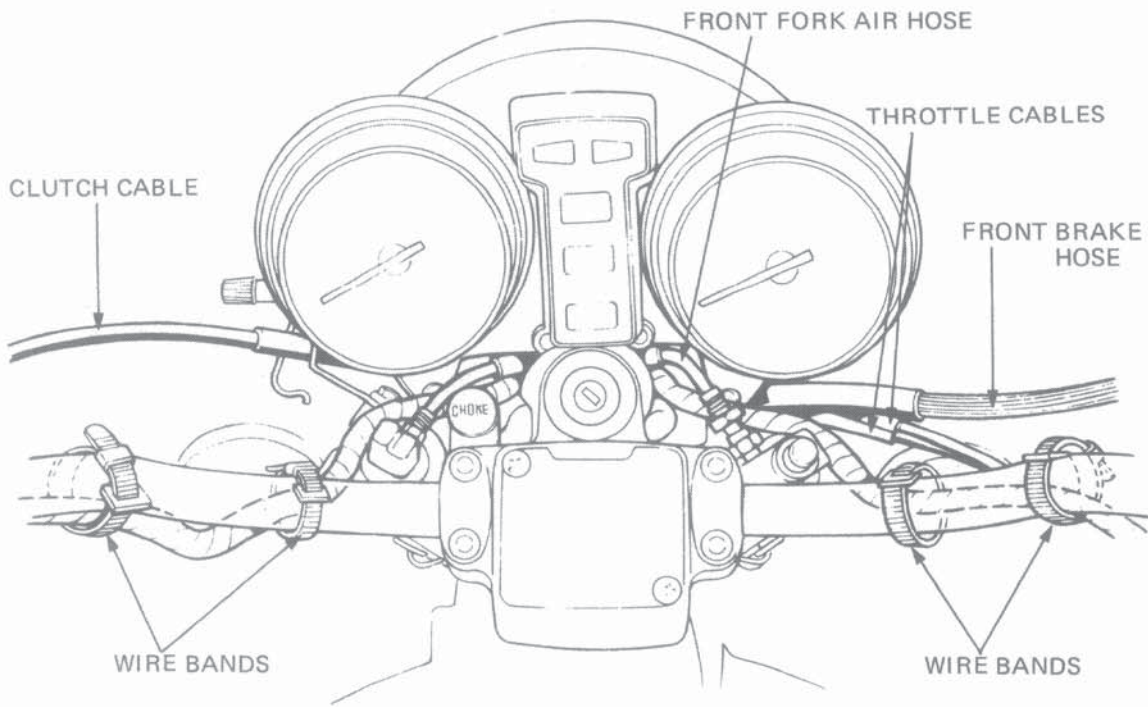





## 2. INSPECTION AND ADJUSTMENT FUEL LINE

Replace any parts which show deterioration, damage or leakage.

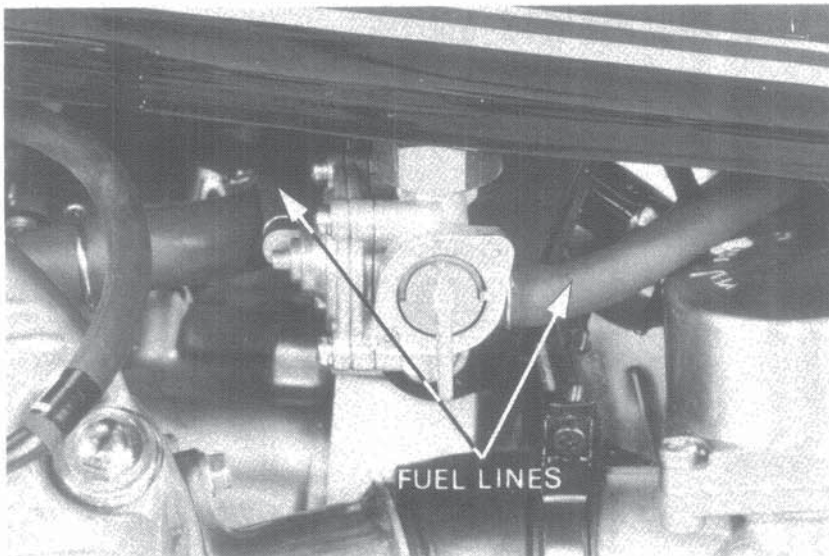

## CARBURETOR SYNCHRONIZATION

### NOTE

This adjustment is performed with engine at normal operating temperature, transmission in neutral, and vehicle on center stand.

Remove the plugs from the carburetor spacers and install adapters.

Connect the vacuum gauges. (see page 3-7).

Start the engine and adjust the idle speed to  $1,100 \pm 100$  rpm.

The difference of vacuum between cylinders should be within 40 mm (1.6 in) Hg.

MUST BE WITHIN 40mm (1.6 in) Hg OF EACH OTHER

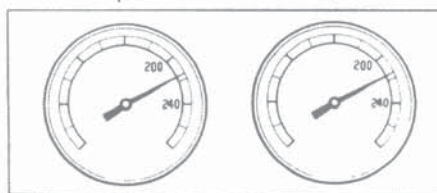

### • ADJUSTMENT

Stop the engine and remove the seat and fuel tank.

Prepare a longer fuel tube and connect it between the fuel tank and carburetor.

Position the tank higher than normal.

Start the engine and adjust the idle speed to  $1,100 \pm 100$  rpm.

Loosen the adjusting screw lock nut.

Balance the vacuum between cylinders to within 40 mm (1.6 in) Hg of each other, by turning the adjusting screw. The No. 1 carb is the base and cannot be adjusted.

Hold the adjusting screw, and tighten the lock nut.

Recheck the synchronization and idle speed.

Reinstall the fuel tank and seat.

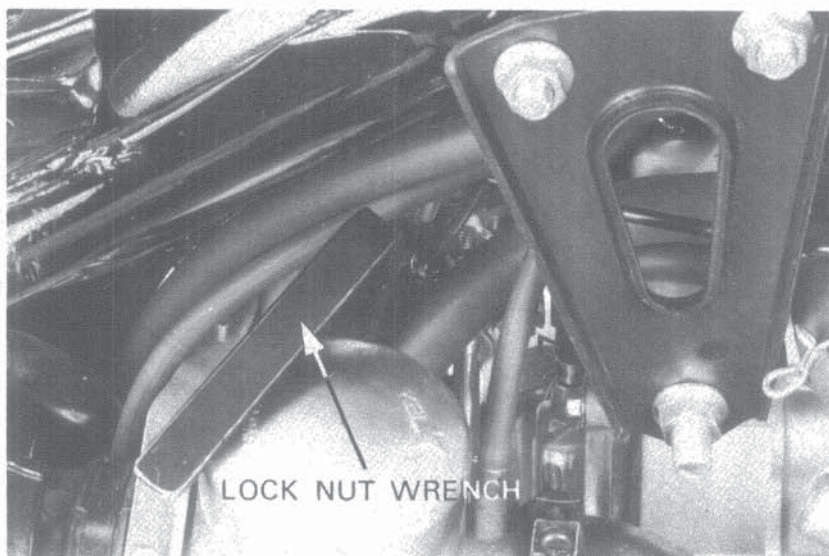



### 3. FUEL SYSTEM

#### WORKING PRACTICE

- The fuel valve is equipped with a fuel line diaphragm. After carburetor overhaul, it is necessary to crank the engine for 2-3 seconds, three times with the throttle fully closed to fill the float chambers.
- For carburetor adjustments, refer to section 4 and the '80 addendum.
- The pilot screw is factory pre-set and should not be removed unless the carburetor is overhauled.

#### TROUBLE SHOOTING

##### Fuel Line Diaphragm

- Fuel not reaching carburetor
  1. Fuel line diaphragm vent tube clogged.
  2. Fuel line diaphragm vacuum tube clogged.
  3. Clogged fuel line diaphragm.
  4. Clogged fuel line diaphragm check valve.

### SPECIFICATIONS

[ ] Canada Model

ITEM	CX500 DELUXE	CX500 CUSTOM
Identification mark	VB28A [VB28B]	VB25A [VB25B]
Venturi diameter	34 mm (1.3 in)	←
Idle speed	1,100 ± 100 rpm	←
Fast idle speed	1,100 - 1,500 rpm	←
Float level	15.5 ± 1 mm	←
Pilot screw opening	See page 23-9	←
Main jets	Primary # 78 Secondary #115	←
Throttle grip free play	2 - 6 mm (1/8 - 1/4 in)	←





## FUEL LINE DIAPHRAGM

### REMOVAL

Turn the fuel valve to OFF.

Remove the seat.

Disconnect the fuel line, vacuum line and air vent tube.

Remove the fuel tank.

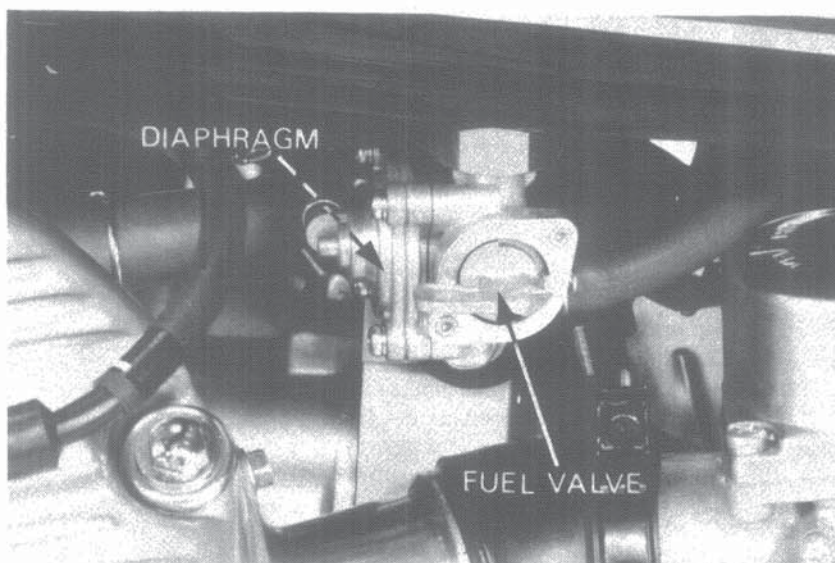

### INSPECTION

Place a suitable drainage container under the fuel line.

Turn the fuel valve to ON.

If fuel comes out of the fuel line, replace the fuel line diaphragm.

Connect a vacuum gauge to the diaphragm vacuum outlet. Fuel should flow from the fuel line when 12–20 mm Hg (0.48–0.8 in Hg) of vacuum is applied.

If flow is restricted, replace the fuel line diaphragm.

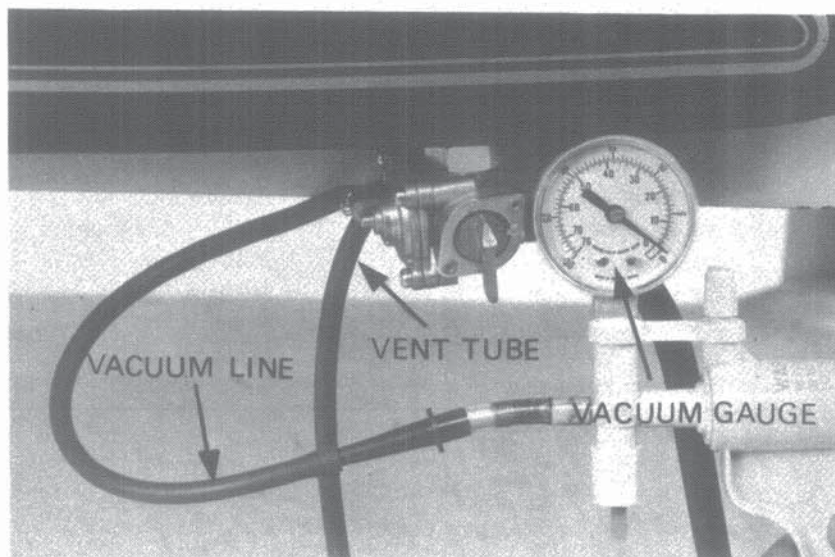

### INSTALLATION

Installation of the fuel line diaphragm is the reverse order of removal.

### NOTE

Be sure all fuel line, vacuum line and air vent tube connections are tight and not leaking.



**HONDA**  
**CX500**

'81 ADDENDUM

---



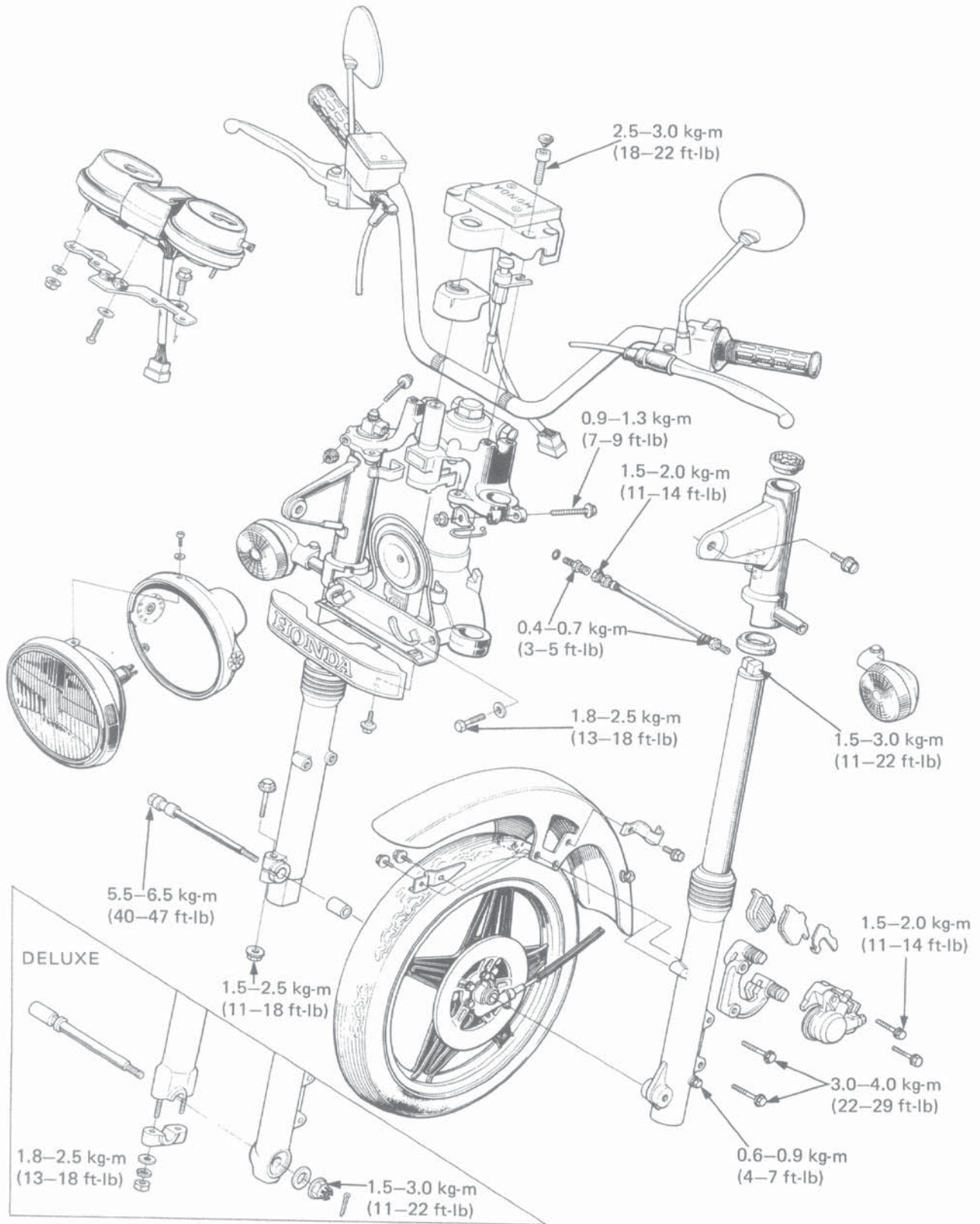



## 4. FRONT WHEEL/SUSPENSION SERVICE INFORMATION

### WORKING PRACTICE

- When removing the front forks, release the air in front fork tubes by depressing the air valve on the right front fork.

### SPECIFICATIONS

ITEM	STANDARD		SERVICE LIMIT	
	CX500 DELUXE	CX500 CUSTOM	CX500 DELUXE	CX500 CUSTOM
Fork spring free length	565.2 mm (22.25 in)	Spring A 100.7 mm ( 3.96 in)	556.6 mm (21.9 in)	Spring A 96.7 mm ( 3.8 in)
		Spring B 503.1 mm (19.8 in)		Spring B 495.1 mm (19.5 in)
Front fork tube O.D.	32.950 – 32.975 mm (1.297 – 1.298 in)	34.950 – 34.975 mm (1.396 – 1.377 in)	32.90 mm (1.295 in)	34.90 mm (1.374 in)
Fork tube run out	—————	—————	0.2 mm (0.01 in)	←—————
Fork fluid capacity	185 cc (6.3 oz)	220 cc (7.5 oz)	—————	—————
Fork air pressure	0.7 – 1.1 kg/cm <sup>2</sup> (10 – 16 psi)	←—————	—————	—————

### TORQUE VALUES

DELUXE: Front axle nut	5.5–6.5 kg-m (40–47 ft-lb)
DUSTOM: Front axle	5.5–6.5 kg-m (40–47 ft-lb)
DELUXE: Axle holder	1.8–2.5 kg-m (13–18 ft-lb)
CUSTOM: Axle holder	1.5–2.5 kg-m (11–18 ft-lb)
Fork bridge bolt	0.9–1.3 kg-m ( 7– 9 ft-lb)
Steering stem pinch bolt	1.8–2.5 kg-m (13–18 ft-lb)
Fork cap bolt	1.5–3.0 kg-m (11–22 ft-lb)
Fork drain bolt	0.6–0.9 kg-m ( 4– 7 ft-lb)
Fork socket bolt	1.5–2.5 kg-m (11–18 ft-lb)
Air hose: right	1.5–2.0 kg-m (11–14 ft-lb)
left	0.4–0.7 kg-m ( 3– 5 ft-lb)
Air hose connector	0.4–0.7 kg-m ( 3– 5 ft-lb)

### TROUBLESHOOTING

#### Soft Suspension

1. Weak springs
2. Insufficient oil in fork tubes
3. Front fork air pressure incorrect

#### Hard Suspension

1. Incorrect oil in front forks
2. Front fork air pressure incorrect

#### Front Suspension Noise

1. Worn slider or tube bushing
2. Insufficient oil in fork tubes
3. Loose front fork fasteners
4. Lack of grease in speedometer gearbox





## CX500 CUSTOM : FRONT WHEEL

### REMOVAL

Raise the front wheel off the ground by placing a support block under the engine.  
Disconnect the speedometer cable by expanding the speedometer cable set spring.

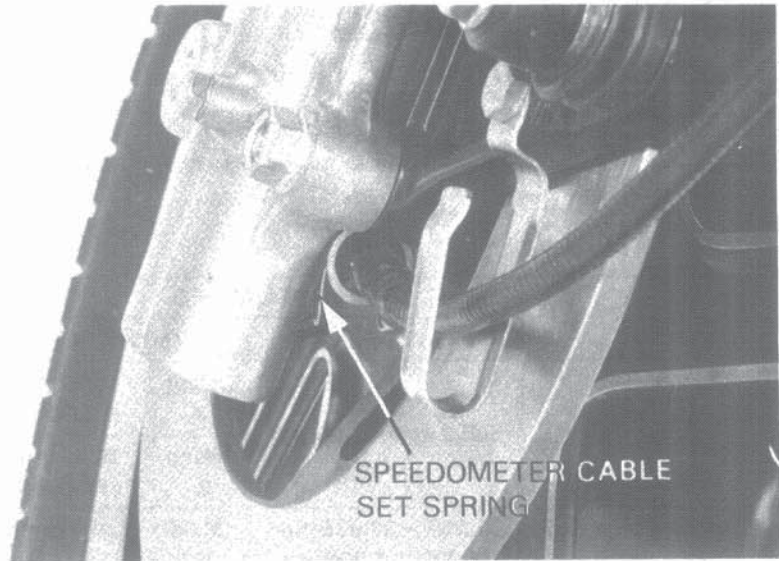

SPEEDOMETER CABLE  
SET SPRING

Remove the front axle holding bolt and nut.  
Unscrew and pull out the front axle.  
Remove the front wheel.

### NOTE

Do not operate the front brake lever after removing the front wheel. To do so will cause difficulty when refitting the brake disc between the brake pads.

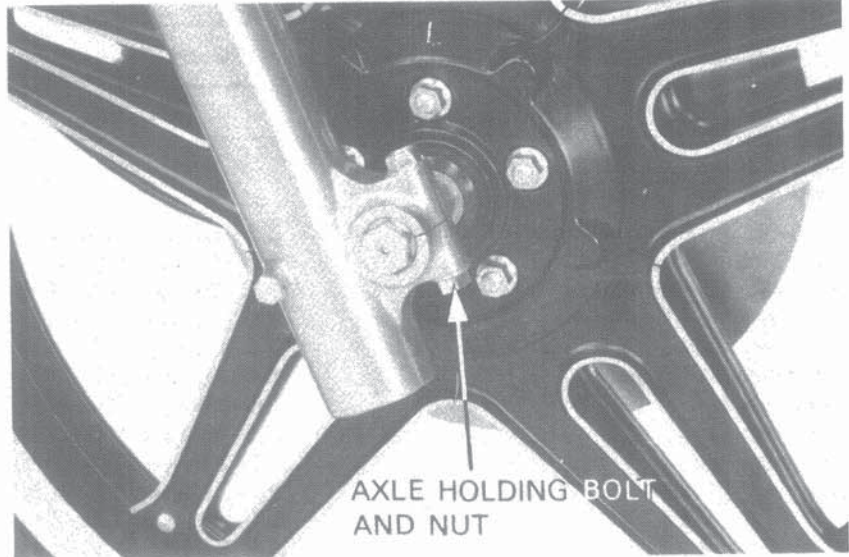

AXLE HOLDING BOLT  
AND NUT

### INSTALLATION

Install the front wheel by inserting the front axle through the right fork leg and wheel hub.

Screw the axle into the left fork leg.

### NOTE

Make sure the speedometer gearbox is perpendicular to the left fork leg.

Tighten the axle to the specified torque.

**TORQUE: 5.5–6.5 kg-m (40–47 ft-lb)**

Install the axle holding bolt and tighten the nut to the specified torque.

**TORQUE: 1.5–2.5 kg-m (11–18 ft-lb)**

After installing the wheel, apply the brake several times and check for free wheel rotation when released.

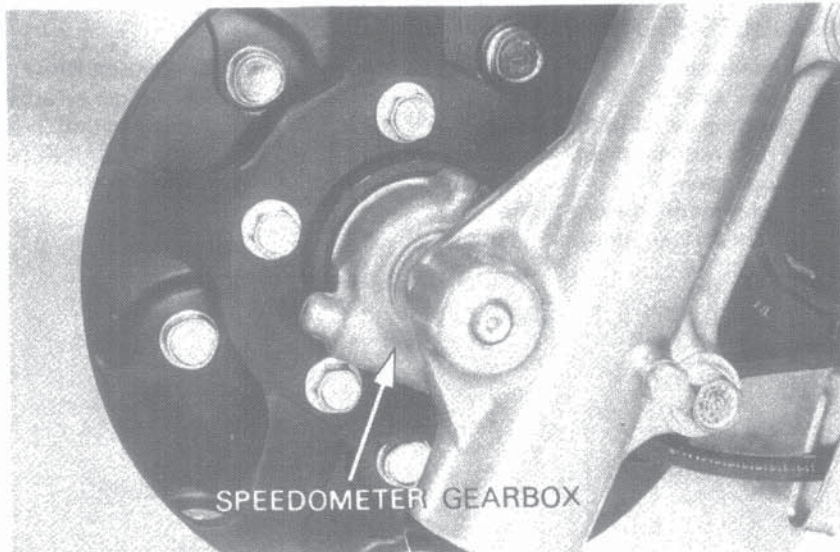

SPEEDOMETER GEARBOX





## FRONT FORKS

### REMOVAL

Remove the speedometer and tachometer cable nuts.

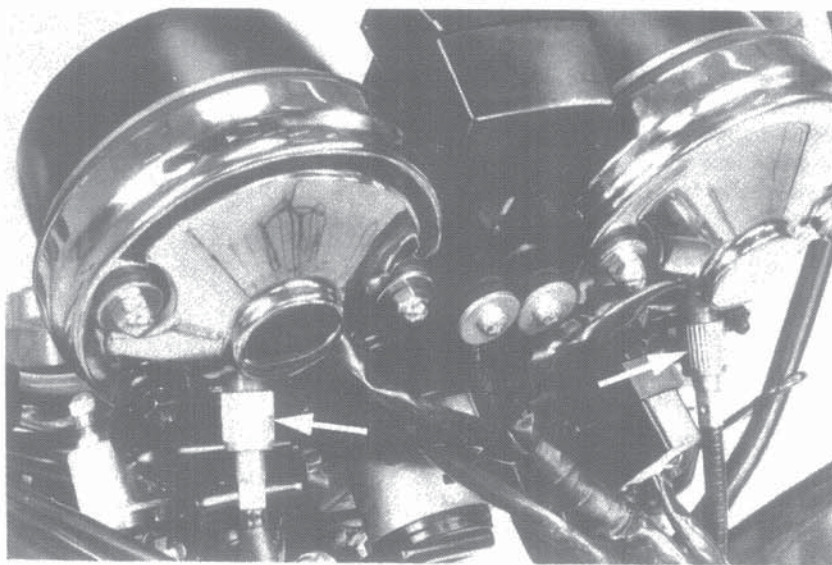

Remove the instrument cluster mounting bolts and the instrument cluster.

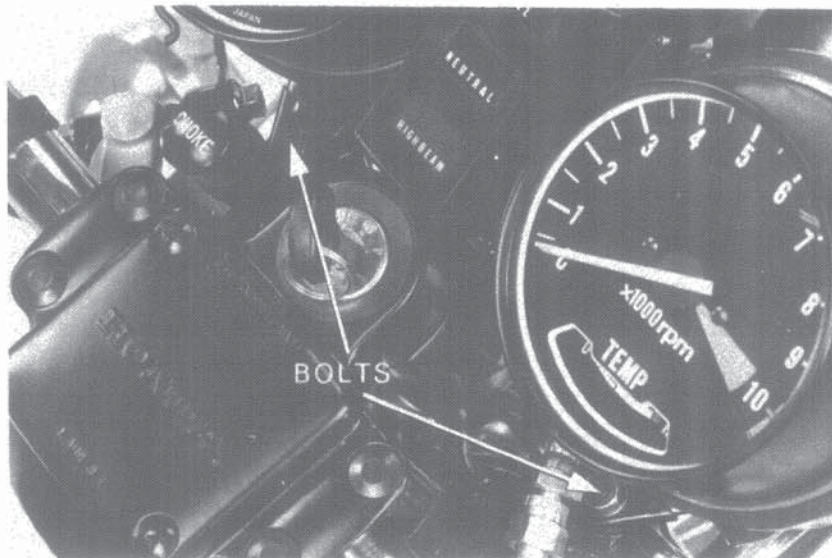

Remove the air valve cap from the air valve on the right fork and release the air in the fork tubes by pressing in on the valve stem. Disconnect the air hose and remove the connectors from the right and left forks.

#### **WARNING**

*The fork tube caps are under air and spring pressure. Front fork air pressure must be relieved and care used before removing the fork tube caps to prevent them from becoming projectiles. Wear eye and face protection.*

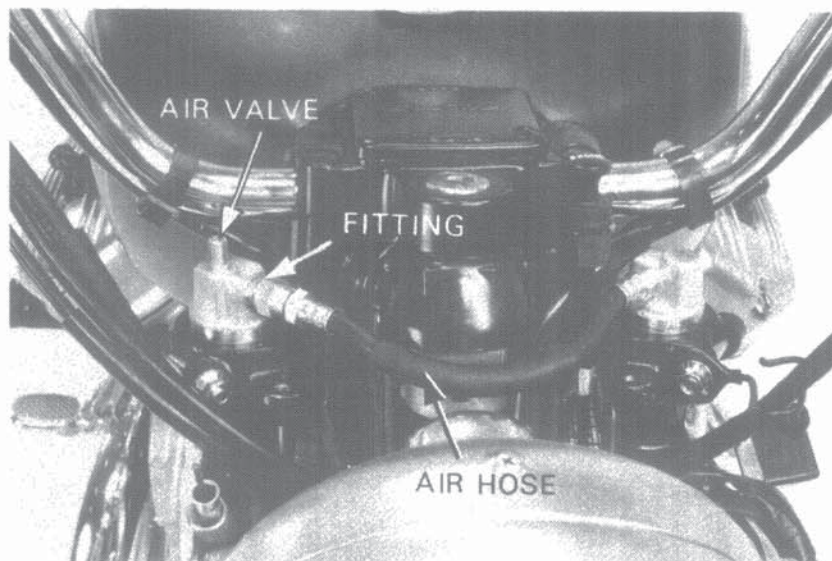





'81 ADDENDUM

Remove the front wheel (DELUXE: see page 13-5, CUSTOM: see page 24-12).  
Remove the brake caliper mounting bolts and caliper.  
Remove the front brake hose from the clip on the front fender.  
Remove the front fender mounting bolts and fender.

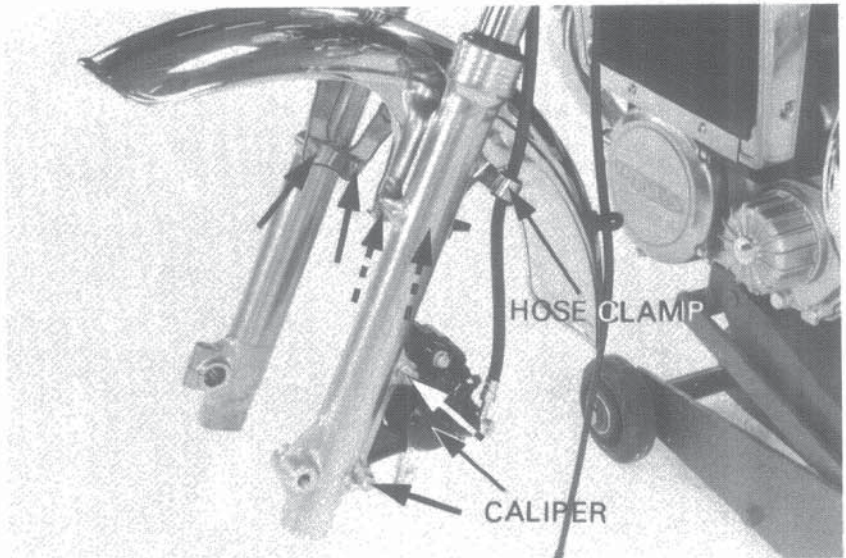

Remove the front emblem by removing the mounting bolts.

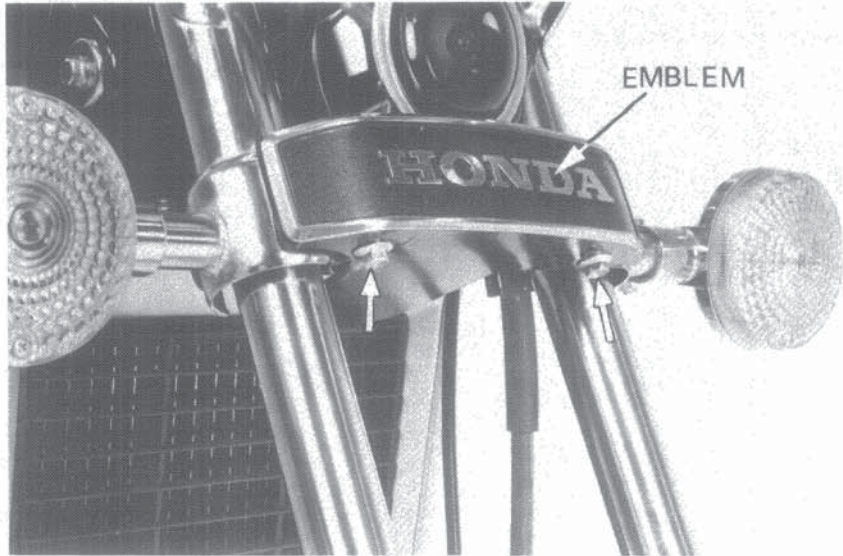

Loosen the front fork tube pinch bolts.  
Pull each fork tube down and out while twisting them.

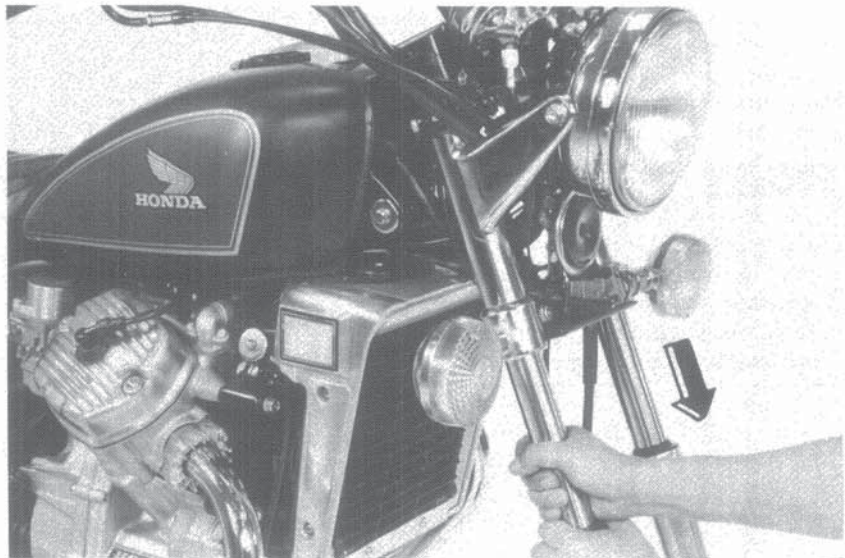





**DISASSEMBLY**

**WARNING**

*The fork tube caps are still under spring pressure. Use care when removing the fork tube caps to prevent them from becoming projectiles. Wear eye and face protection.*

Remove the oil drain bolt and drain the oil.  
Remove the socket bolt from the bottom of fork leg with the hex wrench.

**NOTE**

- Hold the fork slider in a vise with soft jaw, being careful not to overtighten it.
- Temporarily install the spring and fork cap bolt should difficulty be encountered in removing the socket bolt.

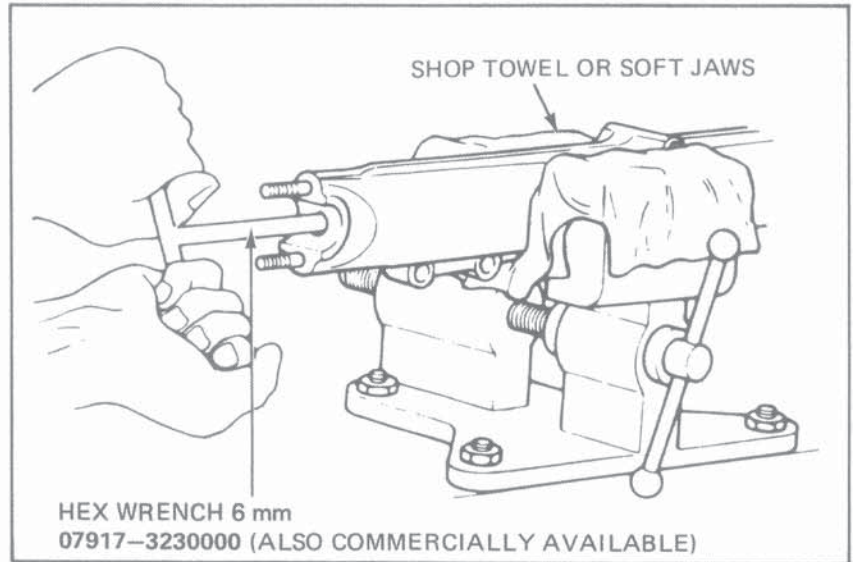

Remove the piston and rebound spring.  
Remove the dust cover.  
Remove the snap-ring and the back-up plate.  
Pull the fork tube out until resistance from the slider bushing is felt.  
Then move it in and out, tapping the bushing lightly until the fork tube separates from the slider. The slider bushing, seal and back-up ring will come out with the fork tube.

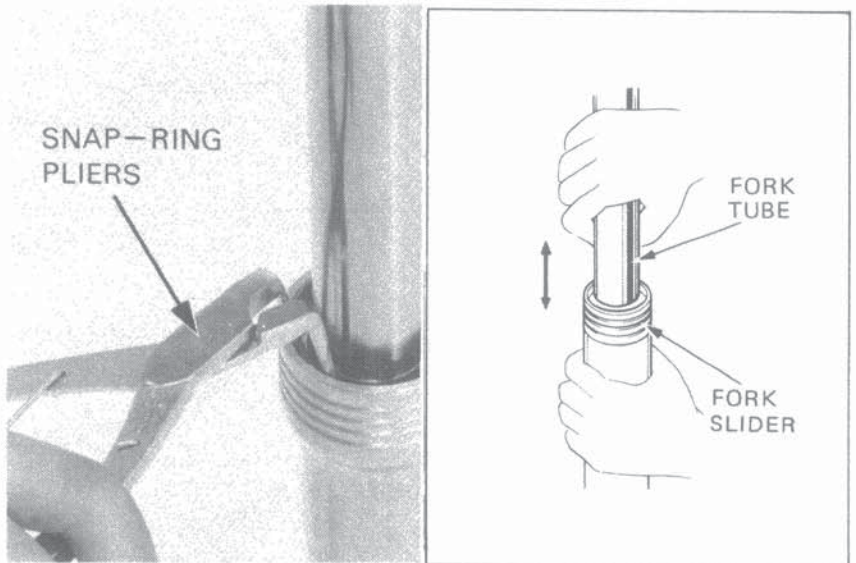

Remove the oil seal and back-up ring from the fork tube.  
Remove the oil lock piece from inside the slider.

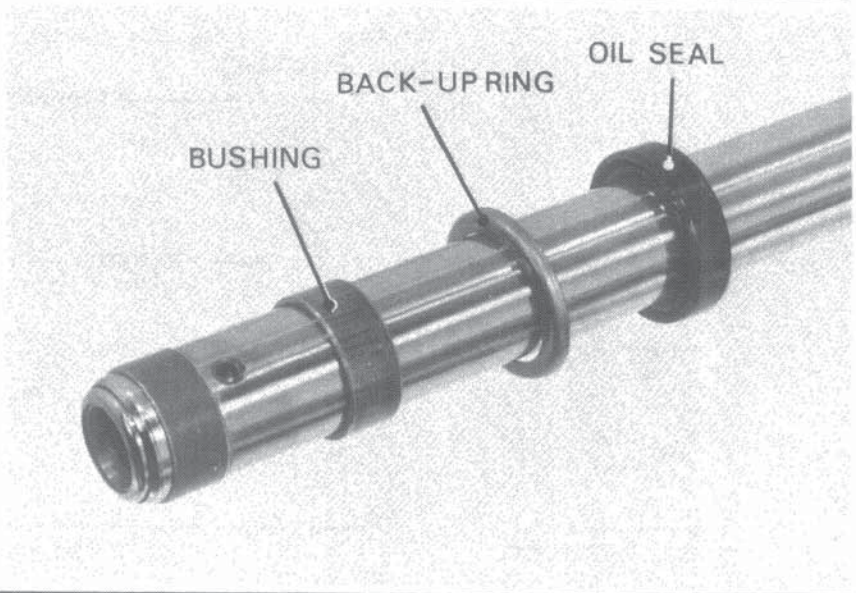





**CX500 DELUXE :**

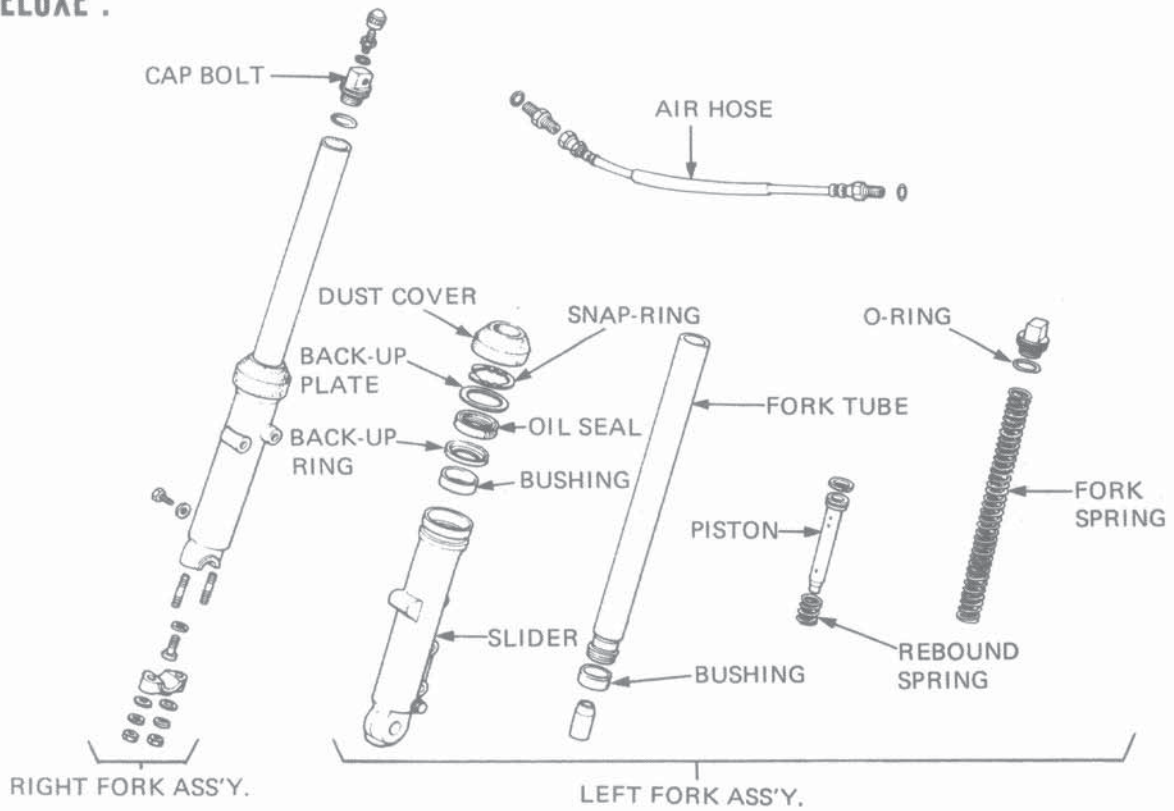

**CX500 CUSTOM :**

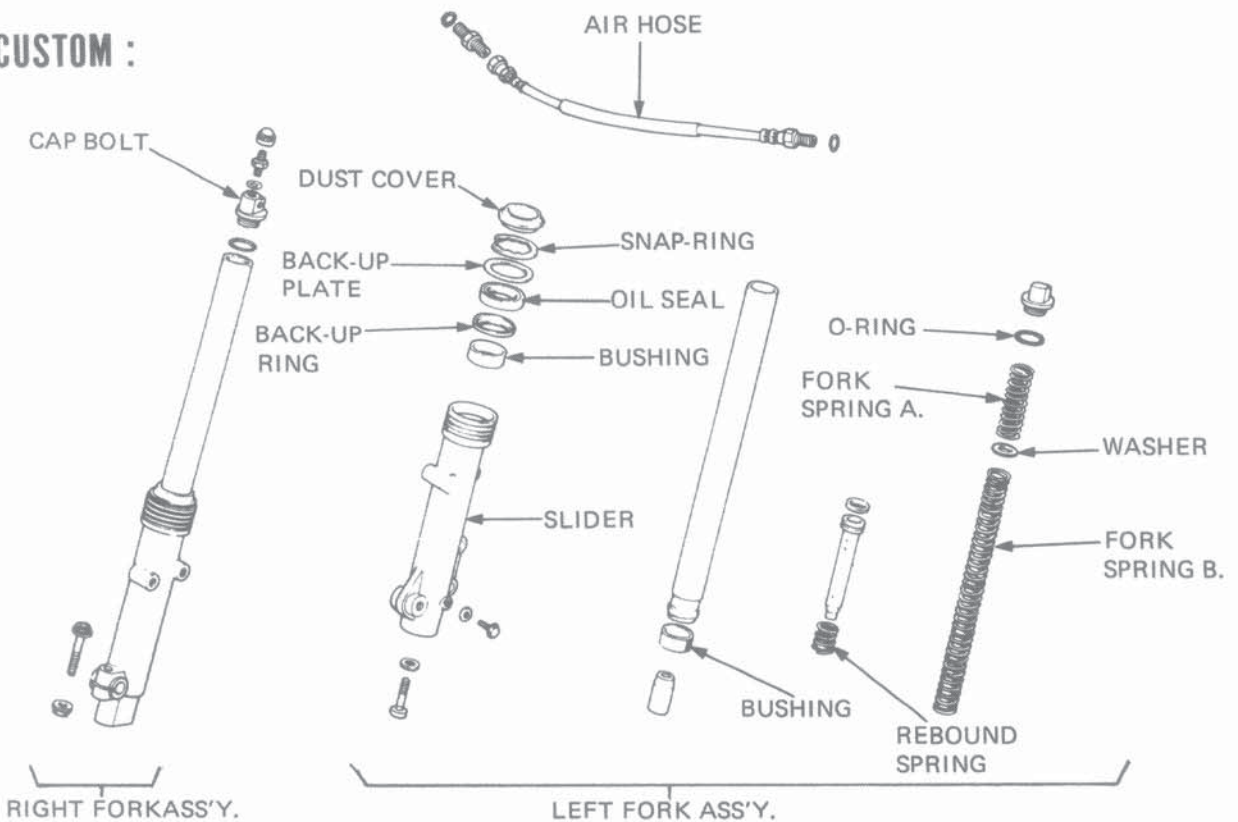



### SPRING FREE LENGTH INSPECTION

Check the free length of the fork springs.  
Replace them if they are shorter than the service limit.

#### SERVICE LIMIT:

DELUXE:	556.6 mm (21.9 in)
CUSTOM: SPRING A:	96.7 mm ( 3.8 in)
SPRING B:	495.1 mm (19.5 in)

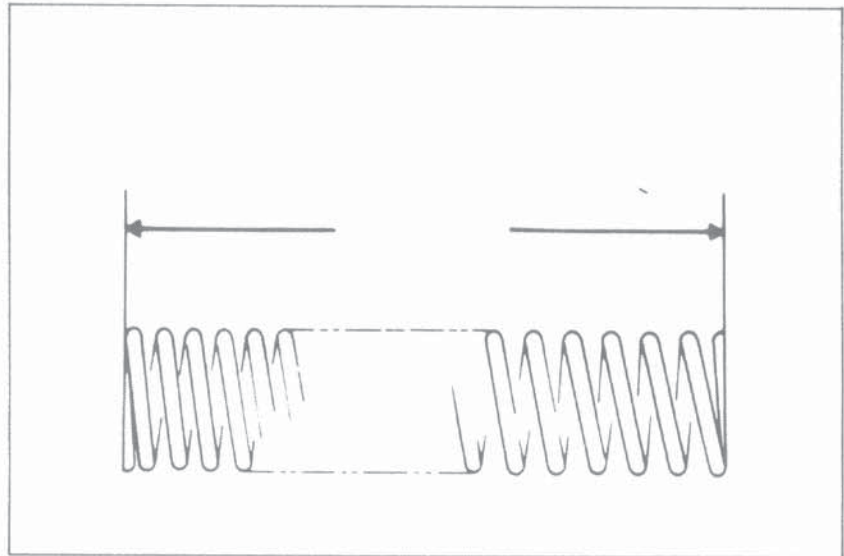

### FORK TUBE/SLIDER/PISTON INSPECTION

Check the fork tubes, fork sliders and pistons for score marks, scratches, excessive or abnormal wear, replacing those parts which cannot be used.

Measure the outside diameter of the fork tubes:

#### FORK TUBE O.D. SERVICE LIMIT:

DELUXE:	32.90 mm (1.295 in)
CUSTOM:	34.90 mm (1.374 in)

### BUSHING/BACK-UP RING INSPECTION

Visually inspect the slider and fork tube bushings.

Replace if there is excessive scoring or scratches, or if the teflon overlay is worn so that the copper surface appears on more than 3/4 of the entire surface.

Check the back-up ring at the points shown.  
Replace if there is any distortion.

### FORK TUBE INSPECTION

Set the fork tube in V blocks and read the runout. 1/2 the total indicator reading is the actual runout.

**RUNOUT SERVICE LIMIT: 0.2 mm (0.01 in)**

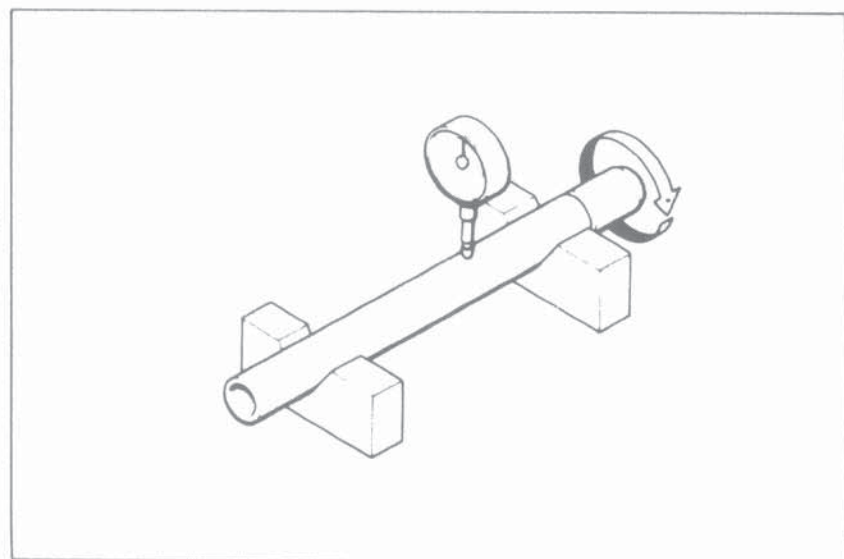
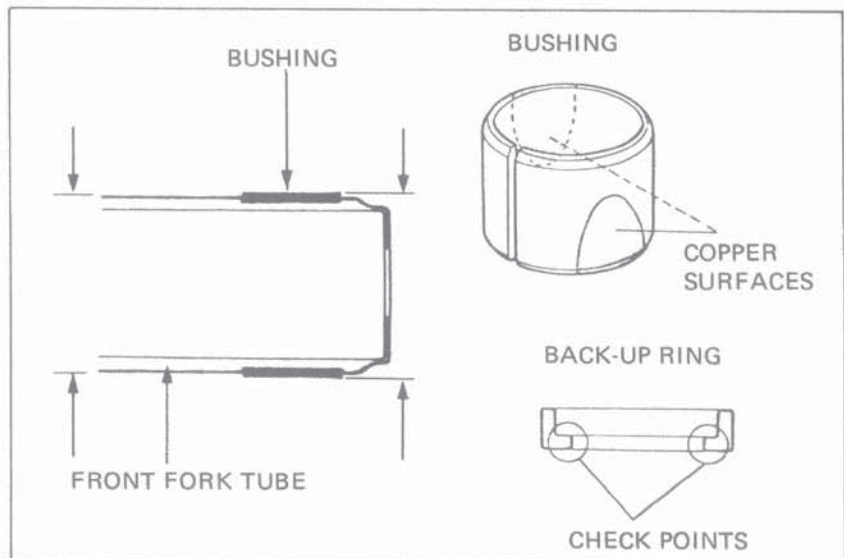





**ASSEMBLY**

Clean all disassembled parts.  
Place the oil lock piece into the slider and insert the fork tube.  
Install the rebound spring and piston into the fork tube.  
Apply a locking agent to the socket bolt and thread it into the piston. Tighten with a hex wrench.

**TORQUE: 1.5–2.0 kg-m (11–14 ft-lb)**

**CAUTION**

*Do not overtighten the fork slider in a vise.*

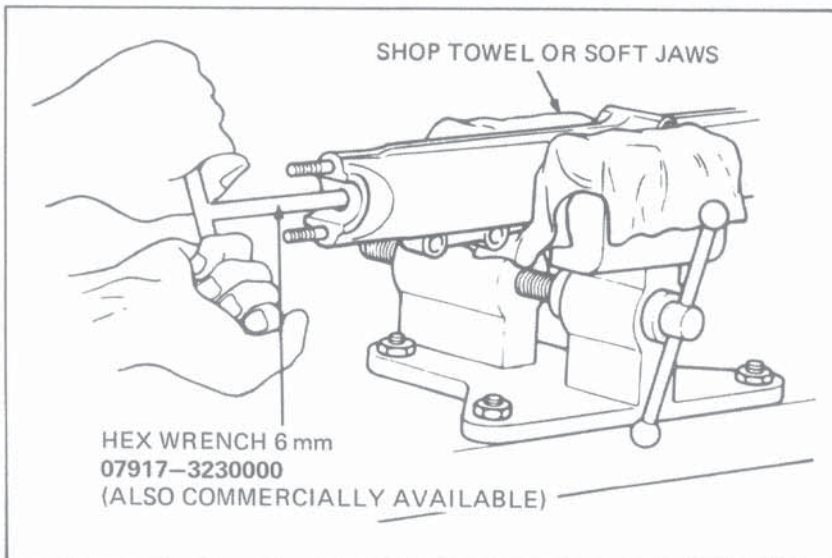

Place the slider bushing over the fork tube and rest it on the slider. Put the back-up ring and on old bushing or equivalent tool on top of the bushing. Drive the bushing into place with the seal driver (P/N 07947-3290000). Remove the old bushing or equivalent tool.  
Dip the new oil seal in ATF and install it over the fork tube with the marks facing up. Drive the oil seal into position until the snap-ring groove appears.

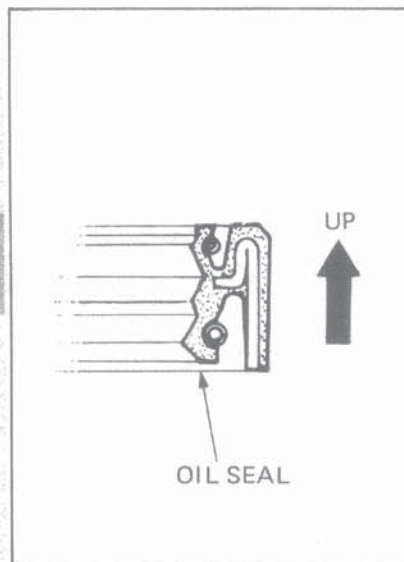
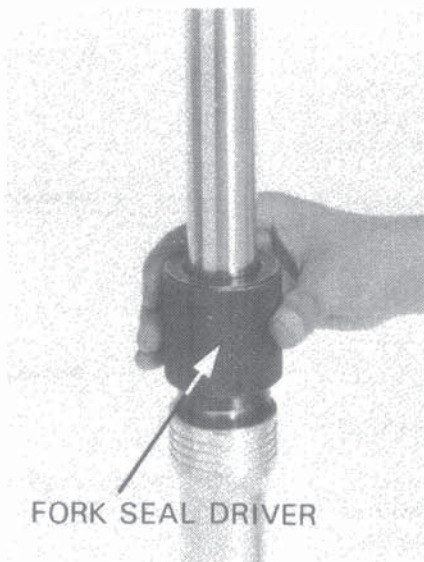

Install the back-up plate.  
Install the snap-ring and dust cover.

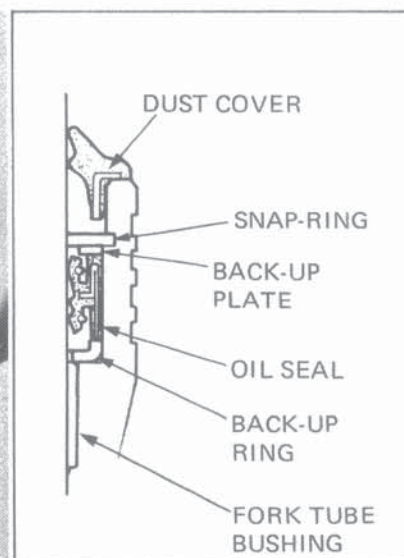
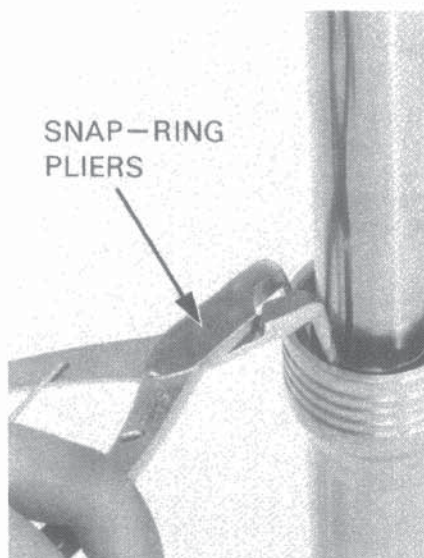



Use ATF (Automatic Transmission Fluid) to fill the front forks.

**CAPACITY:** DELUXE: 185 cc (6.3 oz)  
CUSTOM: 220 cc (7.5 oz)

**NOTE**

Do not overfill.

Slide the fork spring and spring seat into position and install the cap bolt.

**NOTE**

- Place the fork tube in a vise with a shop towel, avoiding the sliding surface.
- Note the spring direction.

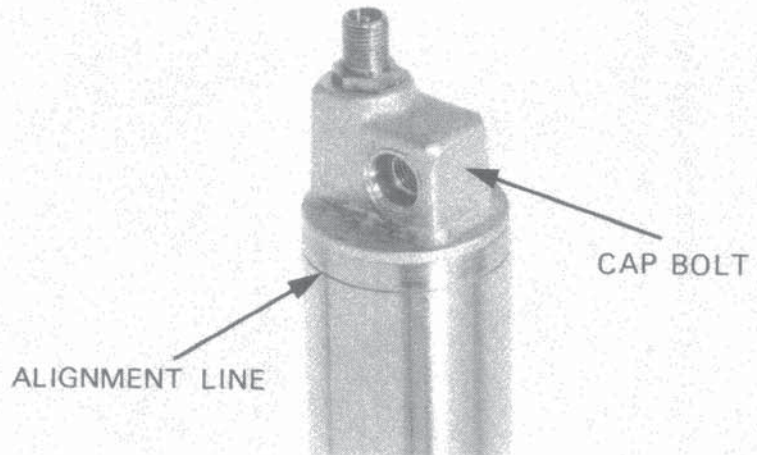

**INSTALLATION**

Install the front fork into the steering stem and bridge, rotating it by hand if necessary.

**NOTE**

Align the front fork alignment line with the top of the bridge.

Tighten the upper and lower fork pinch bolts.

**TORQUE:**

UPPER : 0.9–1.3 kg-m ( 7– 9 ft-lb)  
LOWER: 1.8–2.5 kg-m (13–18 ft-lb)

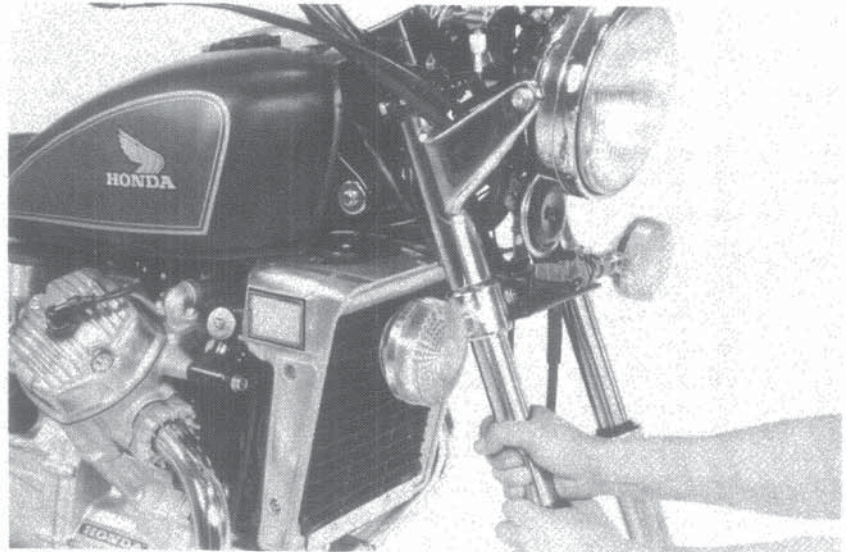

Tighten the fork tube cap bolts.

**TORQUE:** 1.5–3.0 kg-m (11–22 ft-lb)

Apply grease to the new O-rings.  
Place new O-rings on the air hose connectors.  
Install and tighten the air hose connector.

**TORQUE:** 0.4–0.7 kg-m (3–5 ft-lb)

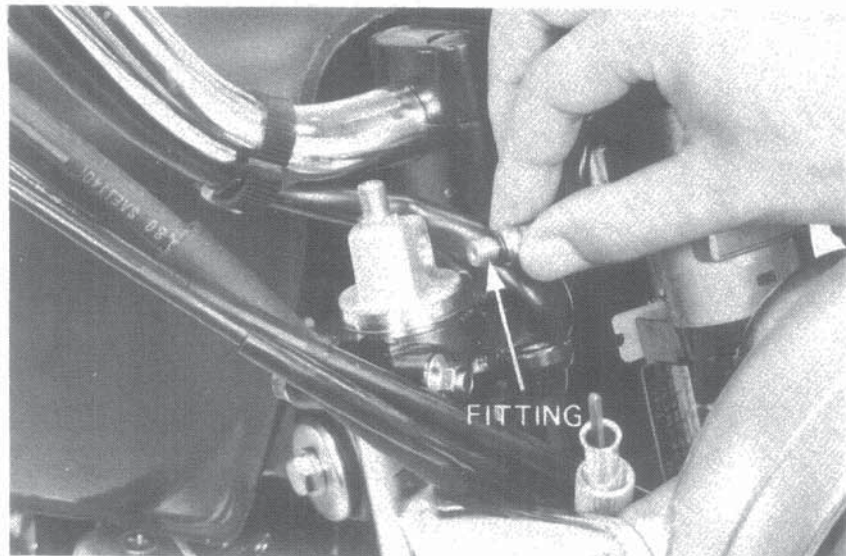





Install the air hose to the left fork cap.

**TORQUE: 0.4–0.7 kg-m (3–5 ft-lb)**

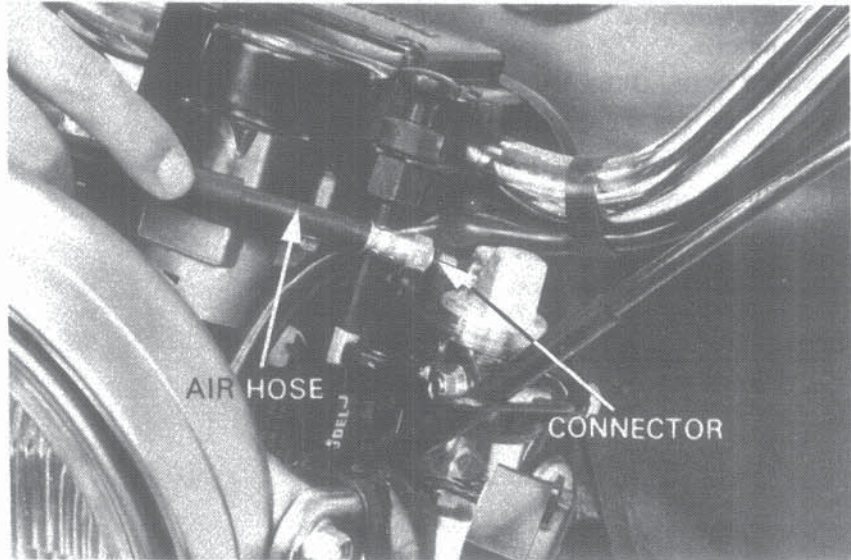

Connect the air hose to the right fork cap.

**TORQUE: 1.5–2.0 kg-m (11–14 ft-lb)**

Install the removed parts in the reverse order of removal.

Use a bicycle air pump to fill the fork-tube with air to the recommended air pressure.

**AIR PRESSURE: 0.7–1.1 kg/cm<sup>2</sup> (10–16 psi)**

**CAUTION**

- Use only a hand operated air pump to fill the fork tubes.  
Do not use compressed air.
- Maximum pressure is 3 kg/cm<sup>2</sup> (43 psi). Do not exceed this or fork tube component damage may occur.

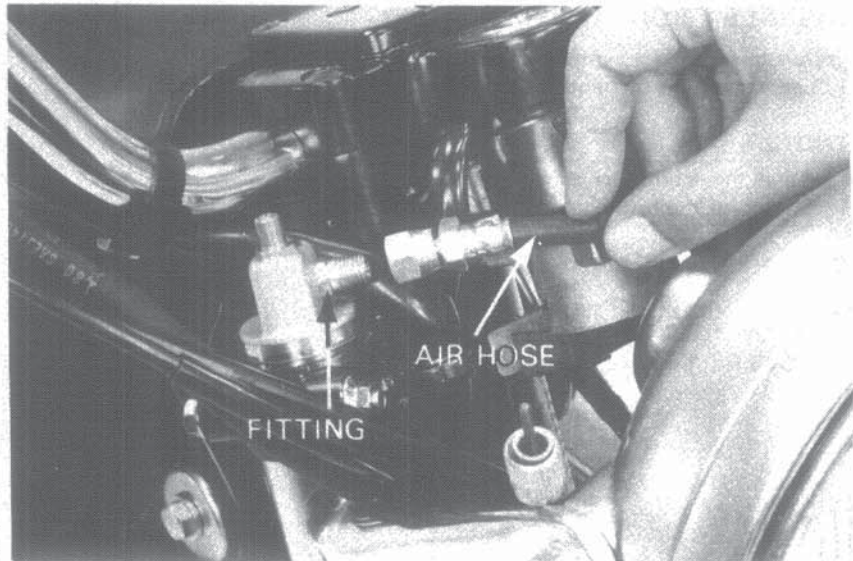

With the front brake applied, pump the front forks up and down several times. Place the motorcycle on its center stand. Check the air pressure and adjust if necessary.





## 5. SWITCHES IGNITION SWITCH

### REMOVAL

Remove the speedometer and tachometer cable nuts. Remove the instrument cluster mounting bolts and the instrument cluster.

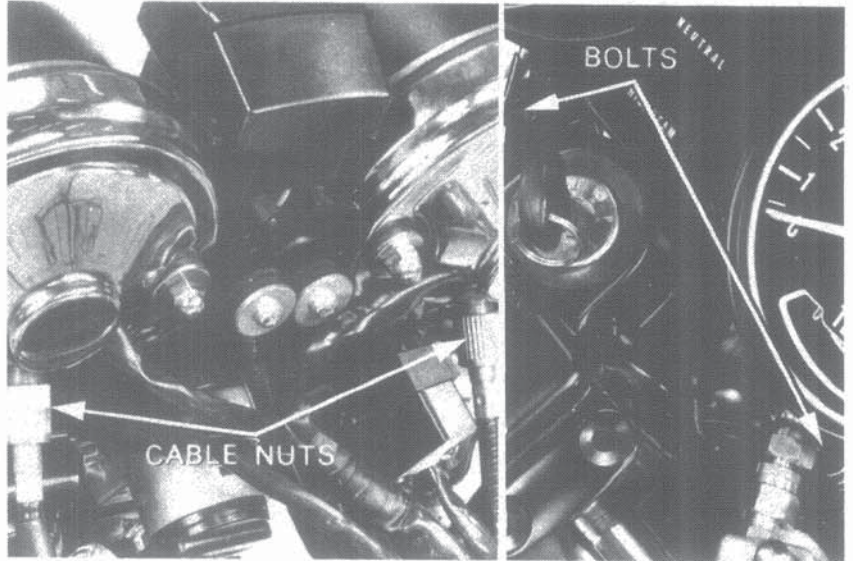

Remove the headlight case mounting bolts and headlight case.

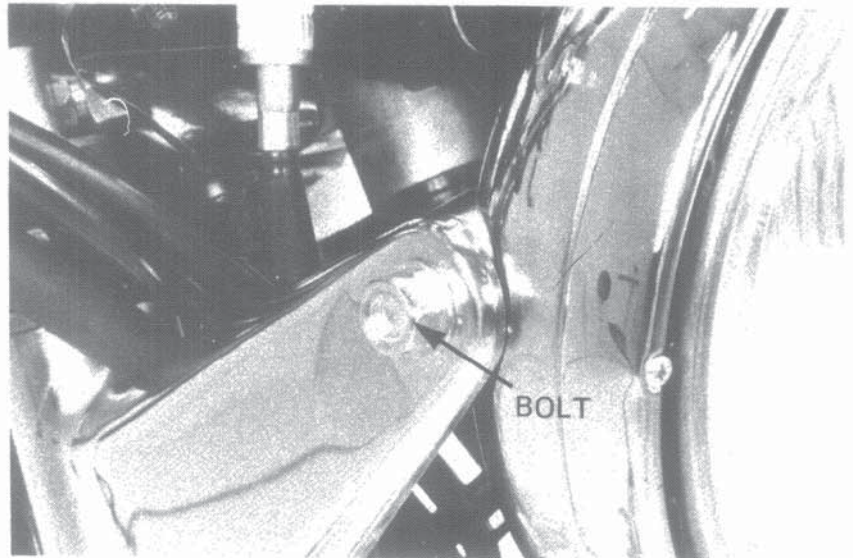

Remove the ignition switch mounting bolts and disconnect the ignition switch coupler.

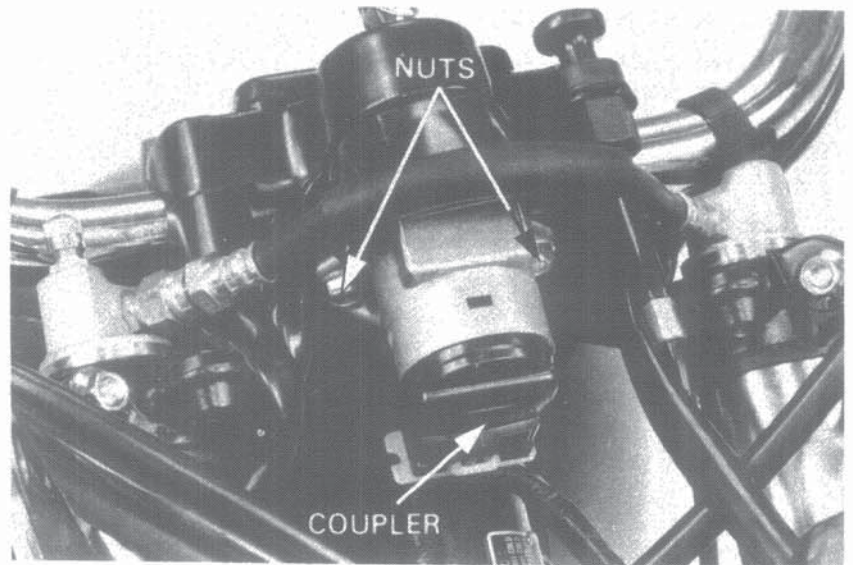





**DISASSEMBLY**

Insert the ignition key into the switch and position it in between the ON and P detents. Push the lugs from the slots and remove the contact base.

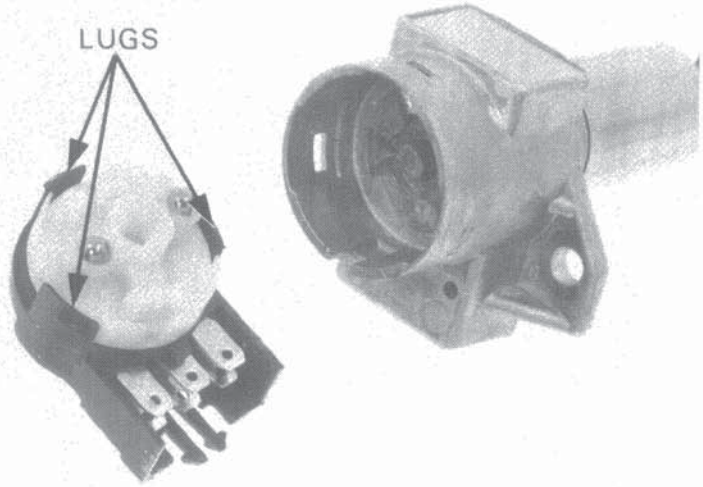
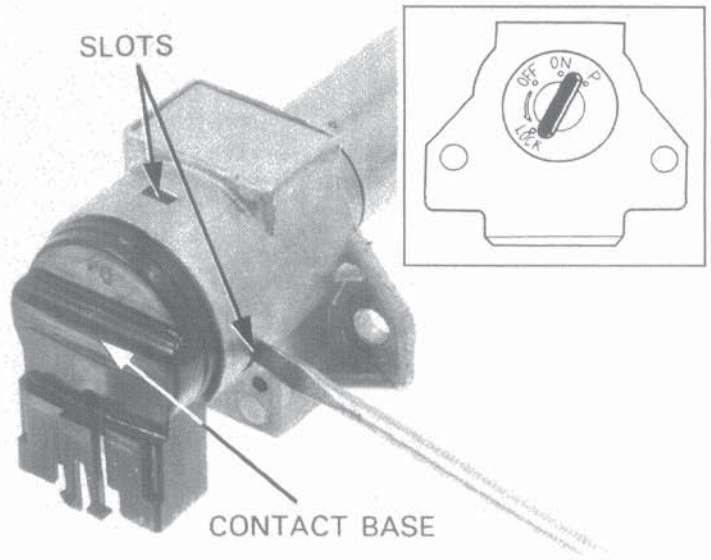

**ASSEMBLY AND INSTALLATION**

Assembly and installation are the reverse order of disassembly and removal.

**NOTE**

When installing the headlight case, align the punch marks on case with the punch marks on the headlight case brackets.

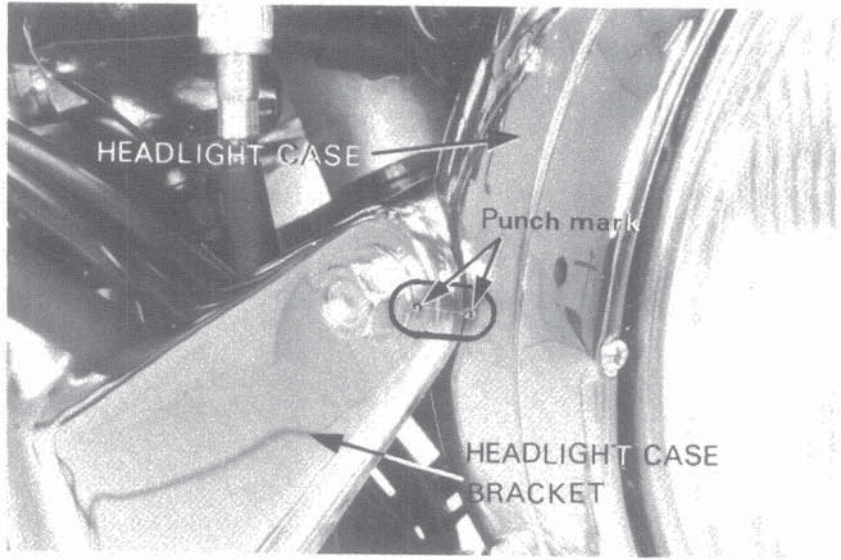









## INTRODUCTION

This addendum contains service information for the 1982 CX500 Custom. Refer to the base shop manual and previous addendums for service information not included in this addendum.

ALL INFORMATION, ILLUSTRATIONS, DIRECTIONS AND SPECIFICATIONS INCLUDED IN THIS PUBLICATION ARE BASED ON THE LATEST PRODUCT INFORMATION AVAILABLE AT THE TIME OF APPROVAL FOR PRINTING. HONDA MOTOR CO., LTD. RESERVES THE RIGHT TO MAKE CHANGES AT ANY TIME WITHOUT NOTICE AND WITHOUT INCURRING ANY OBLIGATION WHATEVER. NO PART OF THIS PUBLICATION MAY BE REPRODUCED WITHOUT WRITTEN PERMISSION.

HONDA MOTOR CO., LTD.  
Service Publications Office

## TABLE OF CONTENTS

- 1. GENERAL INFORMATION ..... 25-2
- SPECIFICATIONS..... 25-2
- MAINTENANCE SCHEDULE..... 25-3
- CABLE AND HARNESS ROUTING..... 25-4
- 2. LUBRICATION ..... 25-5
- 3. INSPECTION AND ADJUSTMENT..... 25-5
- FUEL VALVE STRAINER..... 25-5
- BRAKE FLUID ..... 25-6
- BRAKE PAD WEAR..... 25-6
- 4. CARBURETOR ..... 25-7
- HIGH ALTITUDE ADJUSTMENT ..... 25-7
- 5. AC GENERATOR/FLYWHEEL/  
   REAR COVER..... 25-8
- ENGINE REAR COVER ..... 25-8
- IGNITION TIMING ADJUSTMENT... 25-11
- 6. FRONT BRAKE ..... 25-13
- BRAKE PAD REPLACEMENT..... 25-13
- BRAKE CALIPER..... 25-14
- 7. IGNITION SYSTEM..... 25-18
- 8. WIRING DIAGRAM..... 25-23





## 1. GENERAL INFORMATION

### SPECIFICATIONS

New specifications for the 1982 CX500C are listed below. Refer to the base shop manual and previous addendums for other specifications.

ITEM		SPECIFICATION		
DIMENSIONS	Overall width	855 mm (33.7 in)		
	Overall height	1,195 mm (47.0 in)		
	Wheelbase	1,465 mm (57.7 in)		
	Seat height	790 mm (31.1 in)		
	Foot peg height	335 mm (13.2 in)		
FRAME	Cold tire pressures	Up to 90 kg (200 lbs) load	Front Rear	28 psi (2.0 kg/cm <sup>2</sup> ) 28 psi (2.0 kg/cm <sup>2</sup> )
		Up to vehicle capacity load	Front Rear	28 psi (2.0 kg/cm <sup>2</sup> ) 32 psi (2.25 kg/cm <sup>2</sup> )
	DRIVE TRAIN	Final reduction		3.091 (11/34)
		ELECTRICAL		Ignition Ignition timing "F" mark Full advance Generator
SPARK PLUG	Spark plug	Standard	DR8ES-L (NGK) or X24ESR-U (ND)	
		For extended high speed riding	DR8ES (NGK) or X27ESR-U (ND)	
LIGHTS	Speedometer light	3.4W (2 cp SAE No. 158)		
	Tachometer light	3.4W (2 cp SAE No. 158)		
	Neutral indicator	3.4W (2 cp SAE No. 158)		
	Turn signal indicator	3.4W (2 cp SAE No. 158)		
	High beam indicator	3.4W (2 cp SAE No. 158)		



### MAINTENANCE SCHEDULE

Perform the PRE-RIDE INSPECTION in the Owner's Manual at each scheduled maintenance.

I: INSPECT AND CLEAN, ADJUST, LUBRICATE OR REPLACE IF NECESSARY

C: CLEAN

R: REPLACE

A: ADJUST

L: LUBRICATE

ITEM	FREQUENCY	WHICHEVER COMES FIRST ↓ EVERY	ODOMETER READING [NOTE 3]							REFER TO PAGE
			600 mi. (1,000 km)	4,000 mi. (6,400 km)	8,000 mi. (12,800 km)	12,000 mi. (19,200 km)	16,000 mi. (25,600 km)	20,000 mi. (32,000 km)	24,000 mi. (38,400 km)	
EMISSION RELATED ITEMS	* FUEL LINES				I		I		I	24-6
	* FUEL STRAINER		C	C	C	C	C	C	C	25-5
	* THROTTLE OPERATION		I		I		I		I	3-5
	* CARBURETOR-CHOKE				I		I		I	3-6
	AIR CLEANER	NOTE 1		C	R	C	R	C	R	3-2
	CRANKCASE BREATHER	NOTE 2		C	C	C	C	C	C	3-3
	SPARK PLUGS			R	R	R	R	R	R	23-6
	* VALVE CLEARANCE		I	I	I		I		I	3-4
	ENGINE OIL	YEAR	R		R		R		R	2-2, 25-5
	ENGINE OIL FILTER	YEAR	R		R		R		R	2-2
	* CAM CHAIN TENSION		A	A	A	A	A	A	A	3-5
	* CARBURETOR-SYNCHRONIZE		I		I		I		I	24-6
	* CARBURETOR-IDLE SPEED		I	I	I	I	I	I	I	3-6
	RADIATOR COOLANT				I		I		*R	3-8 9-3
	* RADIATOR CORE				I		I		I	3-8
* COOLING SYSTEM, HOSES & CONNECTIONS		I		I		I		I	3-8	
NON-EMISSION RELATED ITEMS	* DRIVE SHAFT JOINT				L		L		L	2-3
	FINAL DRIVE LUBRICANT				I		I		R	2-3
	BATTERY	MONTH	I	I	I	I	I	I	I	3-9
	BRAKE FLUID (FRONT)	MONTH   2 YEARS *R	I	I	I	I	I	I	*R	25-6
	BRAKE SHOE/PAD WEAR			I	I	I	I	I	I	3-11, 25-6
	BRAKE SYSTEM		I		I		I		I	3-11
	* BRAKE LIGHT SWITCH		I		I		I		I	3-12
	* HEADLIGHT AIM		I		I		I		I	3-13
	CLUTCH		I	I	I	I	I	I	I	3-13
	SIDE STAND				I		I		I	3-14
	* SUSPENSION		I		I		I		I	3-14
	* NUTS, BOLTS, FASTENERS		I		I		I		I	3-15
** WHEELS		I		I		I		I	3-15	
** STEERING HEAD BEARING		I		I		I		I	3-15	

\* SHOULD BE SERVICED BY AN AUTHORIZED HONDA DEALER, UNLESS THE OWNER HAS PROPER TOOLS AND SERVICE DATA AND IS MECHANICALLY QUALIFIED. REFER TO THE OFFICIAL HONDA SHOP MANUAL.

\*\* IN THE INTEREST OF SAFETY, WE RECOMMEND THESE ITEMS BE SERVICED ONLY BY AN AUTHORIZED HONDA DEALER.

- NOTE:
1. Service more frequently when riding in dusty areas.
  2. Service more frequently when riding in rain or at full throttle.
  3. For higher odometer readings, repeat at the frequency interval established here.





### CABLE AND HARNESS ROUTING

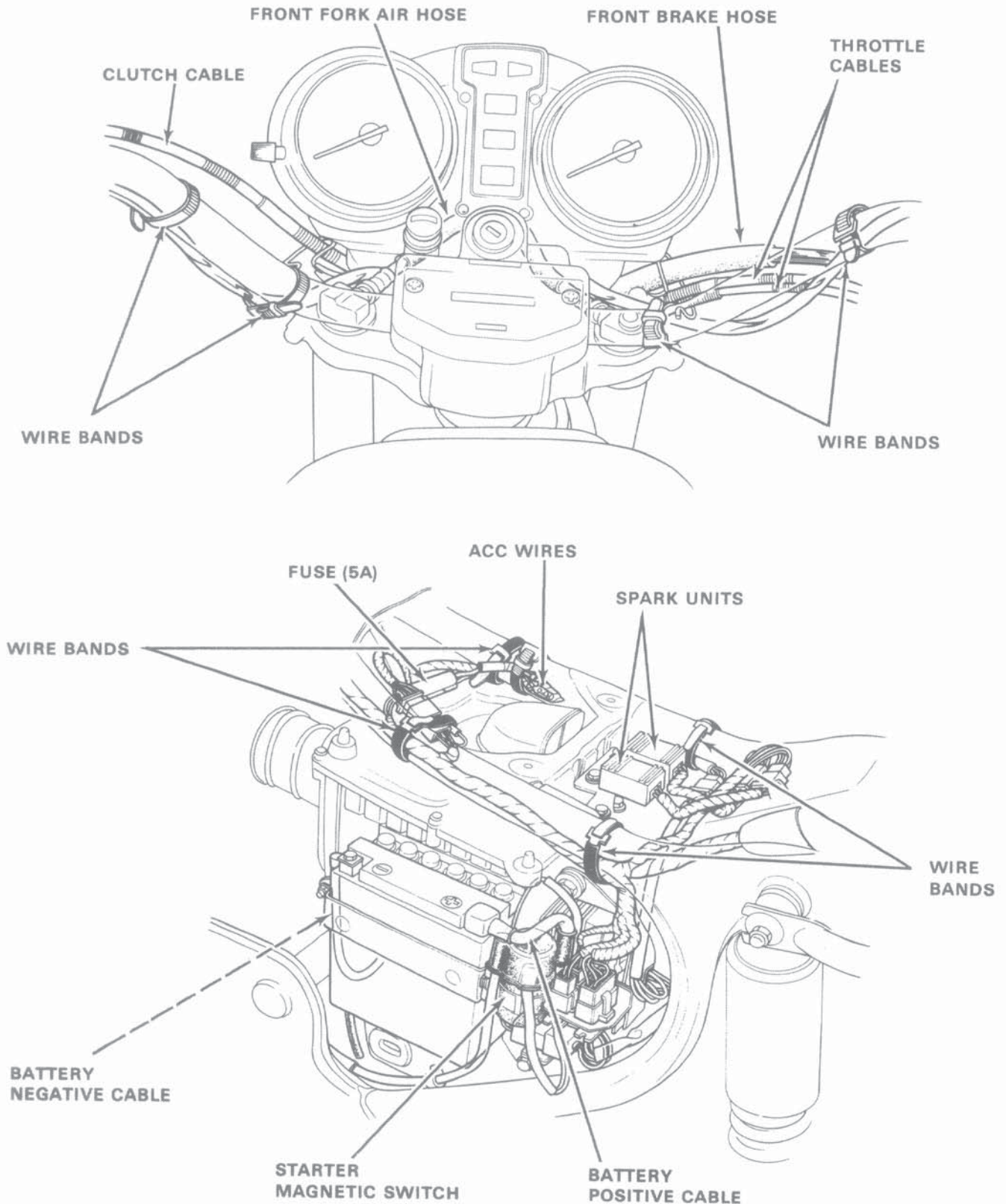



## 2. LUBRICATION

### ENGINE OIL RECOMMENDATION

Use HONDA 4-STROKE OIL or equivalent  
API SERVICE CLASSIFICATION: SE or SF  
VISCOSITY: SAE 10W-40

Other viscosities shown in the chart may be used when the average temperature in your riding area is within the indicated range.

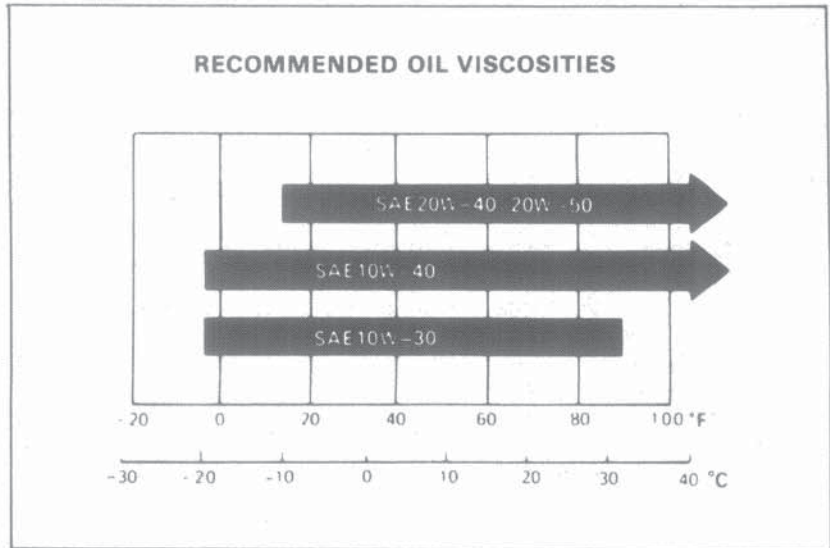

## 3. INSPECTION AND ADJUSTMENT

### FUEL STRAINER

Turn the fuel valve OFF.

Remove the fuel cup, O-ring and filter screen, draining the gasoline into a suitable container.

**WARNING**

*Gasoline is flammable and is explosive under certain conditions. Do not smoke or allow flames or sparks near the equipment while draining fuel.*

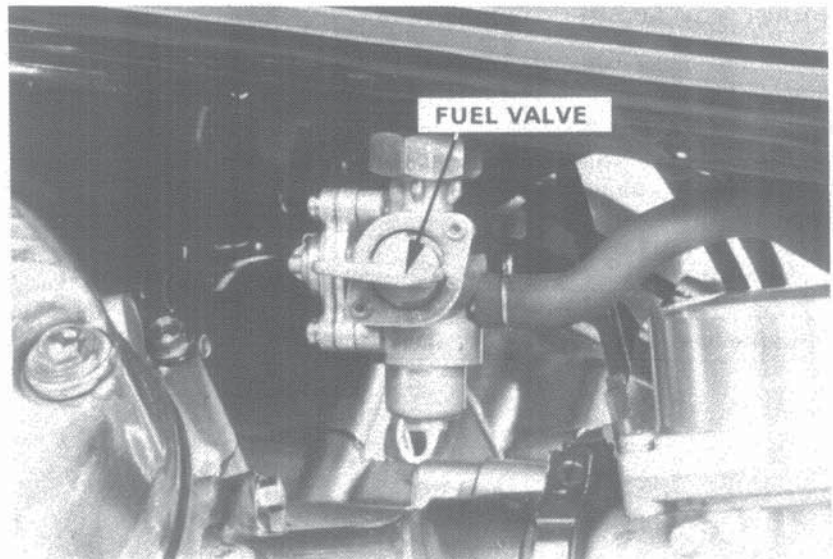

Wash the cup and filter screen in clean non-flammable or high flash point solvent. Reinstall the screen securely, aligning the index marks on the fuel valve body and filter screen.

Install a new O-ring into the fuel valve body. Reinstall the fuel cup, making sure the new O-ring is in place. Hand tighten the fuel cup and then torque it to specification.

**TORQUE: 0.3-0.5 kg-m (2-4 ft-lb)**

After installing, turn the fuel valve ON and check that there are no fuel leaks.

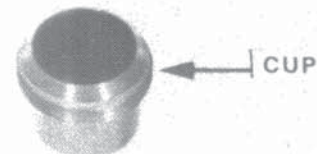





**'82 ADDENDUM**

**BRAKE FLUID**

Check the front brake fluid reservoir level. If the level nears the lower level mark, fill the reservoir with DOT-3 BRAKE FLUID to the upper level mark. Check the entire system for leaks if the level is low.

**CAUTION**

- Do not remove the cover until the handlebar has been turned so that the reservoir is level.
- Avoid operating the brake lever with the cap removed. Brake fluid will squirt out if the lever is pulled.
- Do not mix different types of fluid, as they are not compatible.

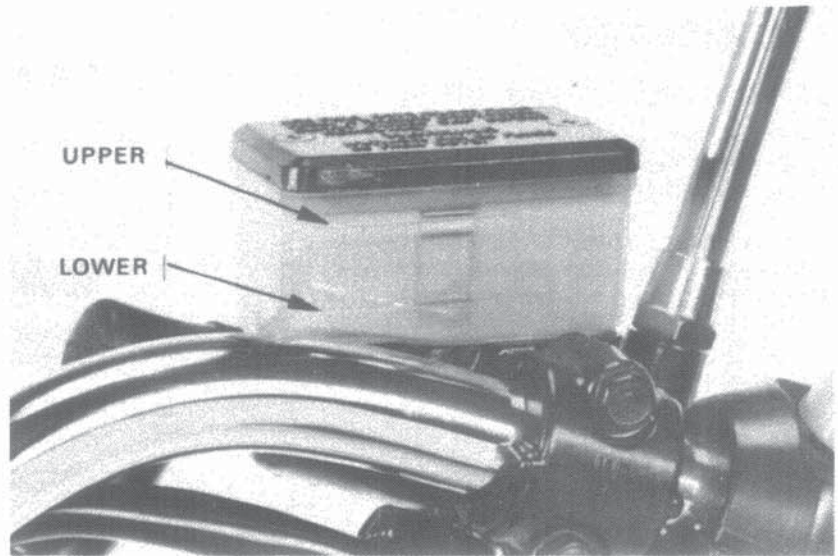

**BRAKE PAD WEAR**

Check the brake pads for wear by looking through the slot indicated by the raised arrow cast on the caliper assembly.

Replace the brake pads if the wear line on the pads reaches the edge of the brake disc (refer to page 25-13).

**CAUTION**

*Always replace the brake pads in pairs to assure even disc pressure.*

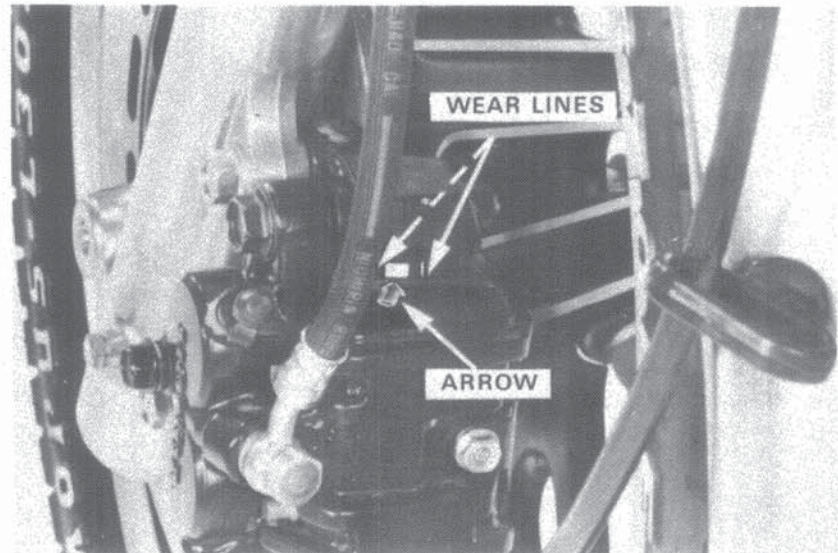



## 4. CARBURETOR

### HIGH ALTITUDE ADJUSTMENT (U.S.A. ONLY)

When the vehicle is to be operated continuously above 6,500 feet (2,000 meters), the carburetors must be readjusted as described below to improve driveability and decrease exhaust emissions.

Warm up the engine to operating temperature. Stop and go driving for 10 minutes is sufficient.

Turn each pilot screw clockwise 1/2 turn.

Adjust the idle speed to  $1,100 \pm 100$  rpm with the throttle stop screw.

#### NOTE

These adjustments must be made at high altitude to ensure proper high altitude operation.

Attach the Vehicle Emission Control Information Update label as shown.

#### NOTE

- Instructions for obtaining Vehicle Emission Control Update labels are given in Service Newsletter No. 132.
- Do not attach the label to any part that can be easily removed from the vehicle.

#### CAUTION

*Operation at an altitude lower than 5,000 feet (1,500 meters) with the carburetors adjusted for high altitudes may cause the engine to idle roughly and stall.*

When the vehicle is to be operated continuously below 5,000 feet (1,500 meters); turn each pilot screw counterclockwise to its original position against its stop and adjust the idle speed to  $1,100 \pm 100$  rpm. Be sure to do these adjustments at low altitude.

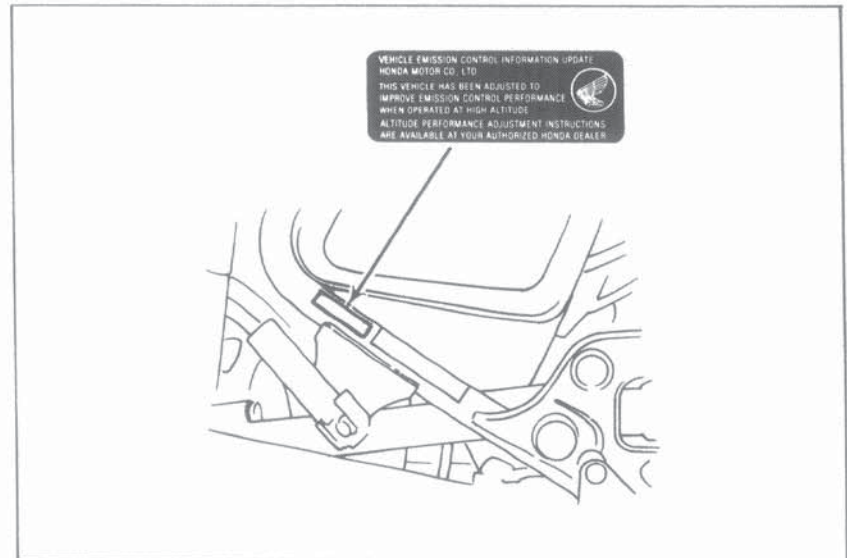
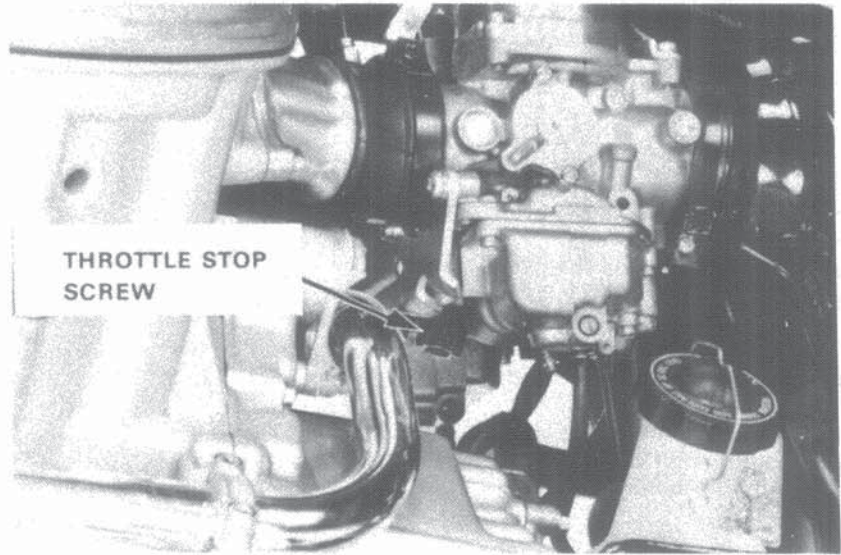





## 5. AC GENERATOR/ FLYWHEEL/REAR COVER

### SERVICE INFORMATION GENERAL INSTRUCTIONS

- To inspect and adjust the pulse generator, see page 25-22.
- Be sure to adjust the ignition timing whenever the rear engine cover is removed.
- The starter motor and water impeller can be serviced with the engine installed in the frame. The swingarm must be removed first (see page 14-23).
- Take care not to cut the AC generator and starter wires and wire harness when removing or installing parts.

## ENGINE REAR COVER

### REAR COVER REMOVAL

Drain engine oil.

Remove the engine from the frame or remove the swingarm.

Remove the water pipe, gearshift pedal, drive shaft dust cover and starter motor.

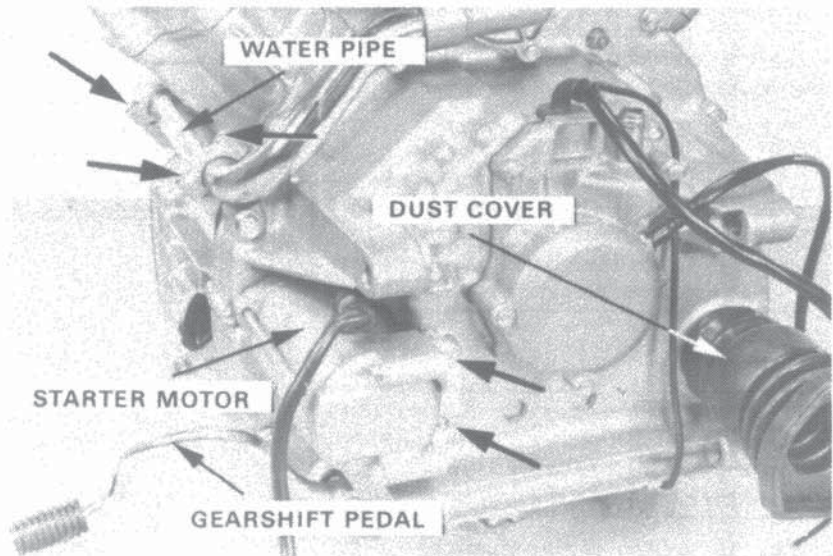

Remove the water pump cover.

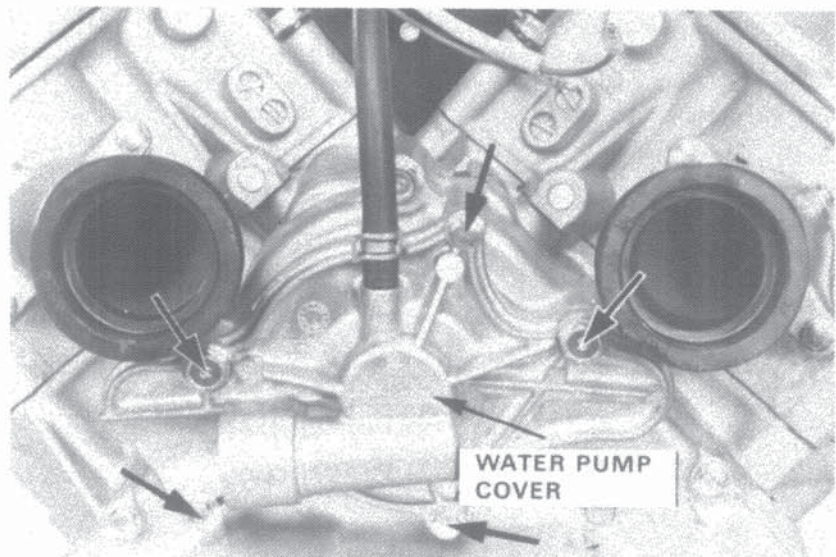





Remove the dowel pins.

Remove the cap nut, copper washer and pump impeller.

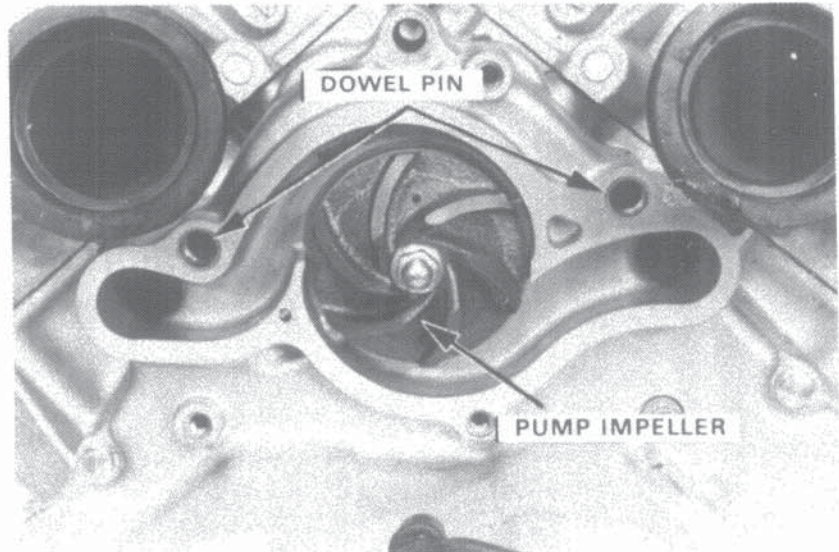

### PULSE GENERATOR REMOVAL

Remove the pulse generator cover.

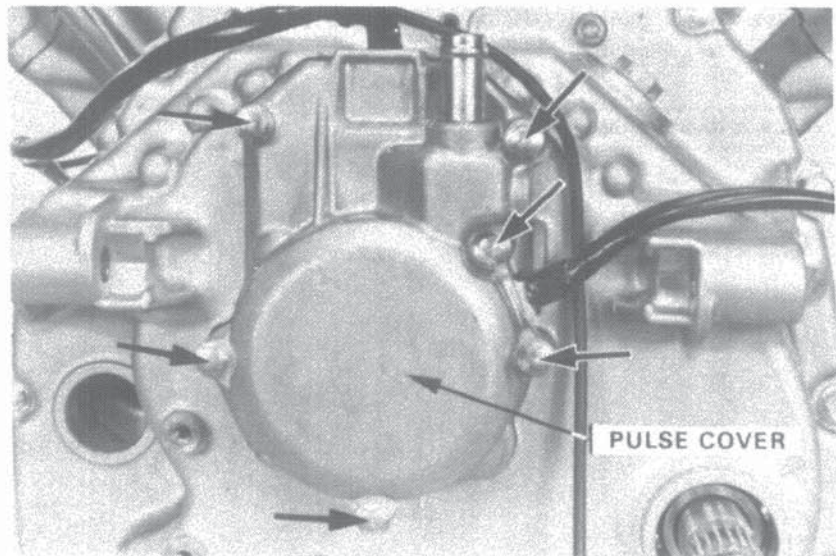

Remove the pulse generator by removing the two mounting screws.

Remove the spark advancer bolt and spark advancer.

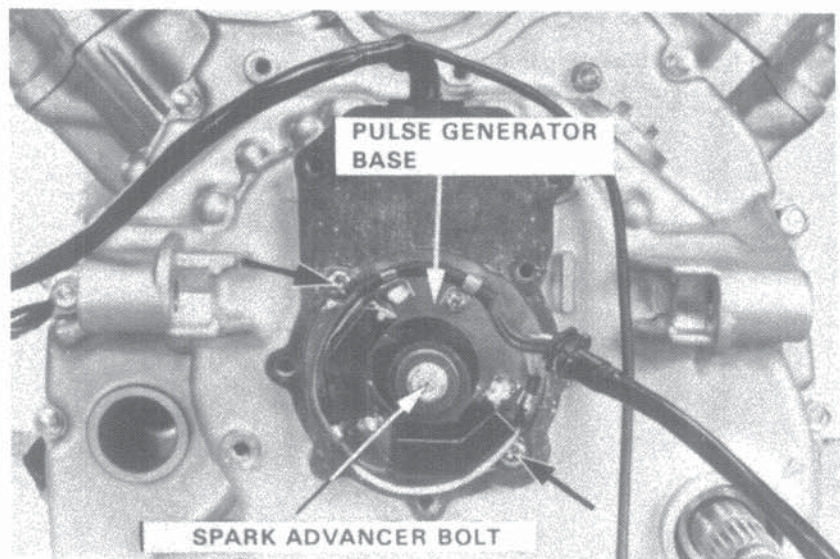



Remove the neutral switch and the rear cover.

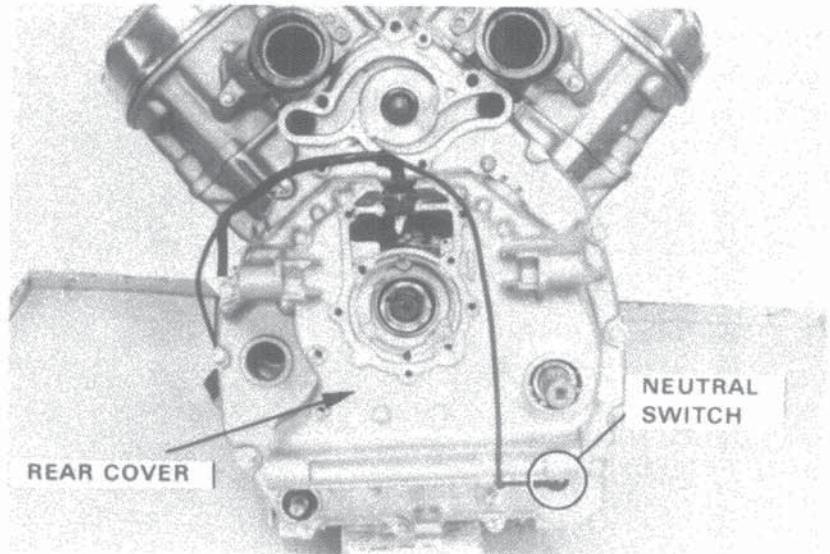

Remove the AC generator stator and remove the final shaft bearing.

**NOTE**

Do not damage the stator coil.

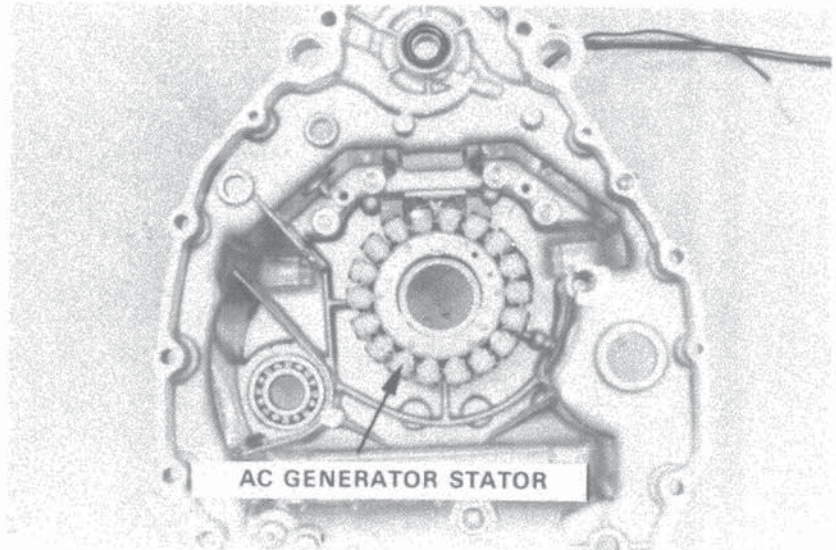

**REAR COVER INSTALLATION**

Drive the final shaft bearing into the rear cover. To install the water pump mechanical seal, refer to page 9-7.

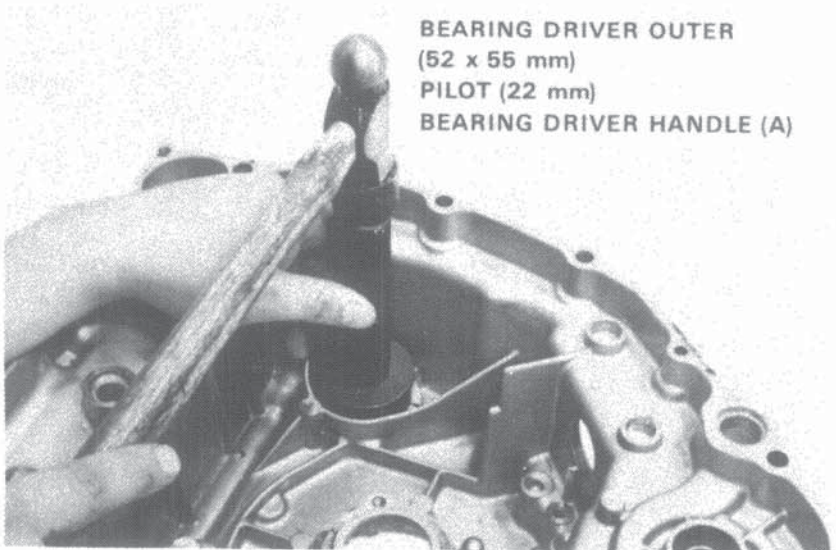





Engage the starter drive gear with the reduction gear.  
Install the rear cover and torque the bolts to specification.

**TORQUE:**

- 6 mm bolts: 0.8-1.2 kg-m (6-9 ft-lb)
- 8 mm bolts: 1.8-2.5 kg-m (13-18 ft-lb)

**NOTE**

- Tighten the rear cover bolts in a criss-cross pattern in 2-3 steps.

Install the starter motor and neutral switch.

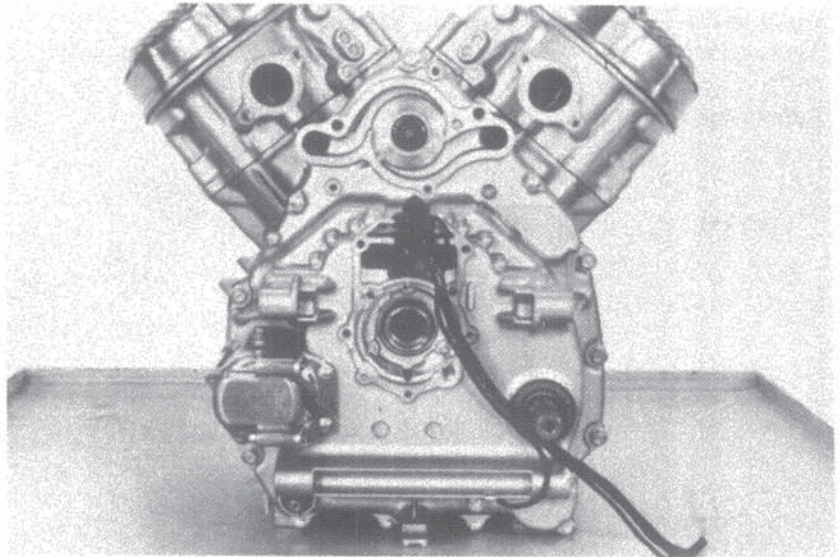

Install spark advancer. Align the lug on the advancer with the cut-out in the crankshaft.  
Tighten the spark advancer attaching bolts.

**TORQUE: 0.8-1.2 kg-m (6-9 ft-lb)**

Install the swingarm (see page 14-27).

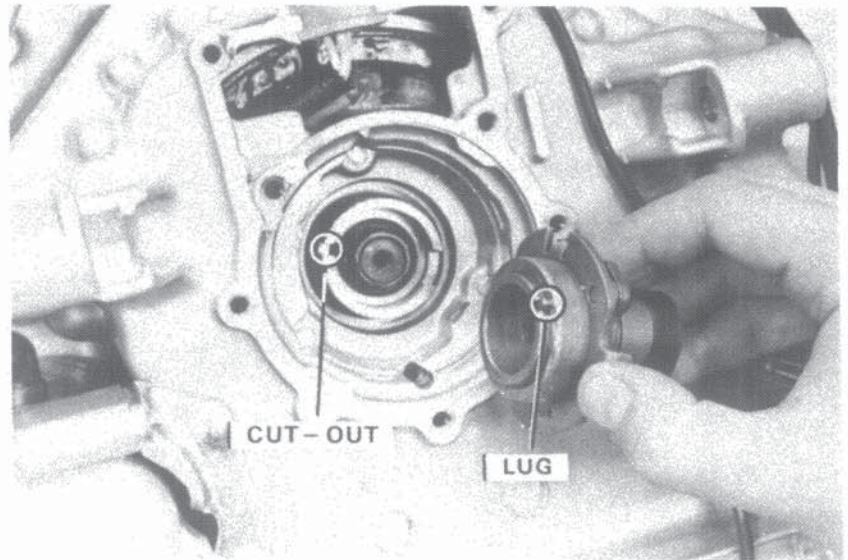

### IGNITION TIMING ADJUSTMENT

Remove the timing inspection hole cap.

Rotate the crankshaft, and align the "FS" mark on the "TR" (right) side with the index mark on the rear cover.

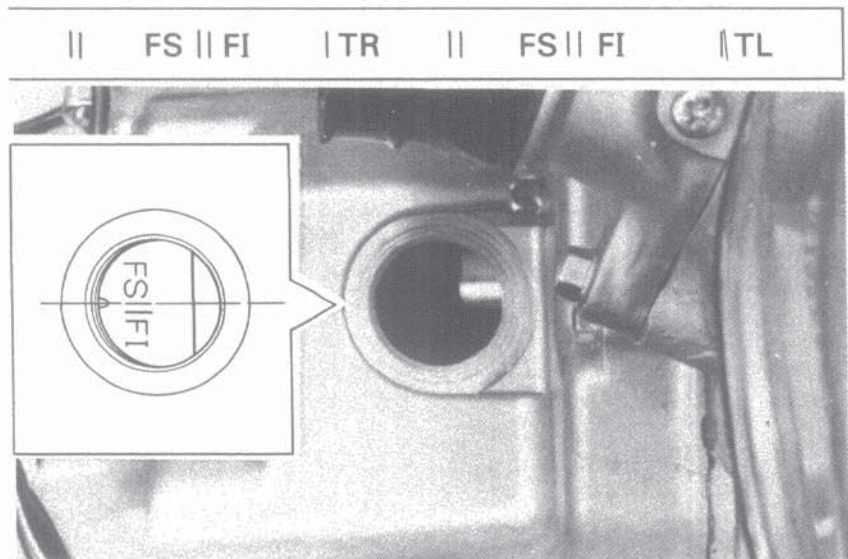





**'82 ADDENDUM**

Install the pulse generator assembly aligning the steel core on the coil case with the rotor tooth.

Tighten the screws securely.

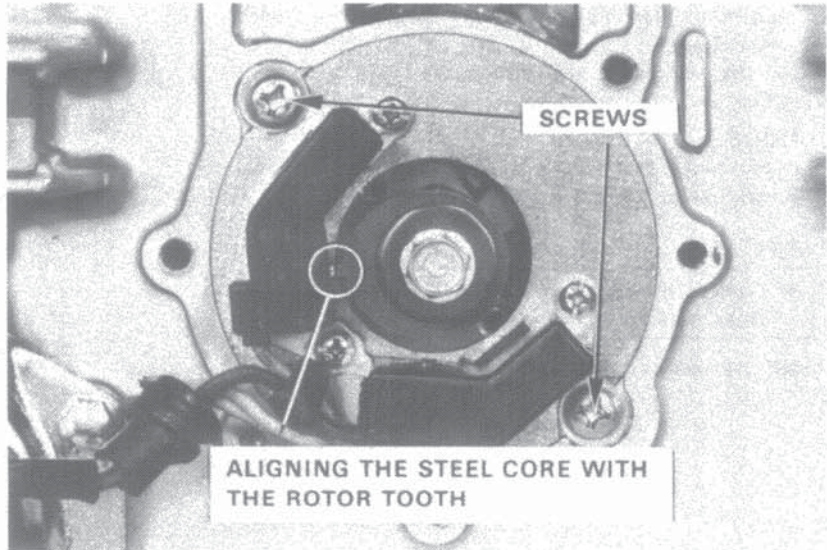

Rotate the crankshaft clockwise, and align the "FS" mark on the "TL" (left) side with the index mark on the rear cover. Check that the rotor tooth is aligned with the steel core on the lower coil case.

Check the air gap between the rotor tooth and the steel core.

**AIR GAP: 0.40-0.70 mm (0.016-0.028 in)**

For air gap adjustment, refer to page 25-22.

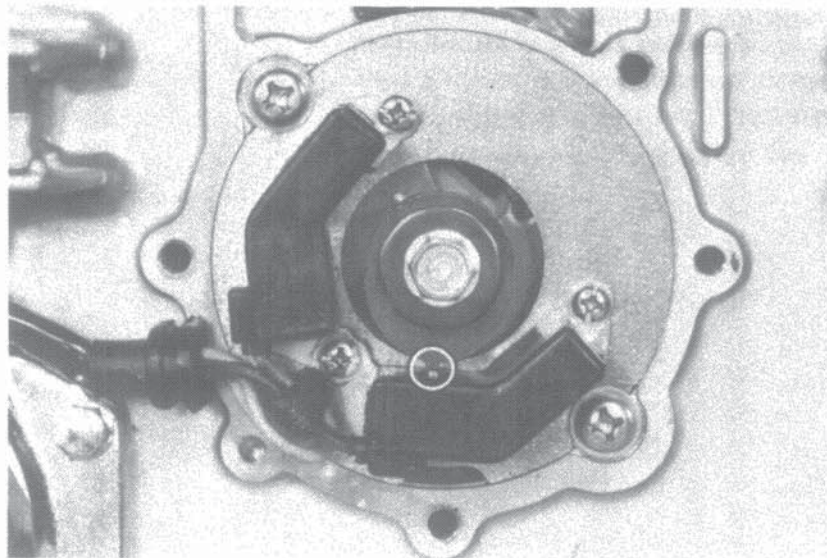

Install the pump impeller, water pump cover and water pipe.

Install the pulse generator cover.

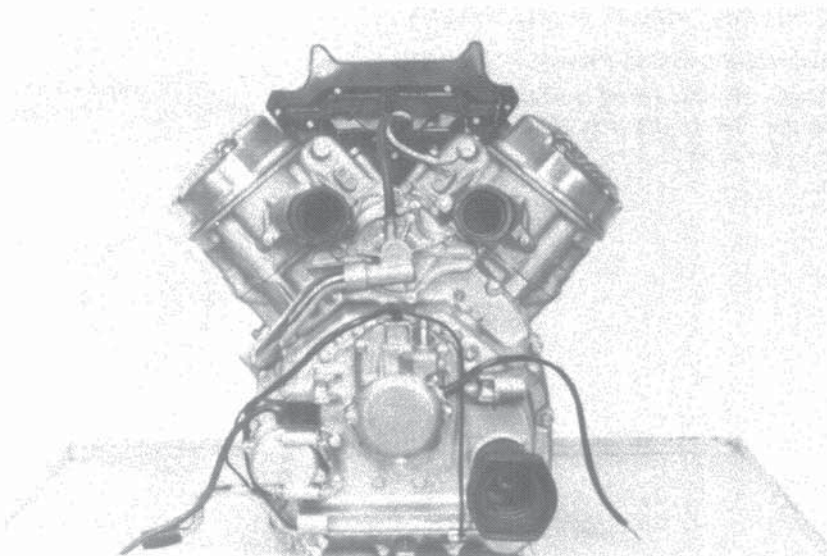





## 6. FRONT BRAKE

### SPECIFICATIONS

ITEM	STANDARD	SERVICE LIMIT
Disc plate thickness	5 mm (0.20 in)	4 mm (0.16 in)
Disc plate runout	—	0.3 mm (0.01 in)
Master cylinder I.D.	15.870-15.913 mm (0.6248-0.6245 in)	15.925 mm (0.6270 in)
Master piston O.D.	15.827-15.857 mm (0.6231-0.6243 in)	15.815 mm (0.6226 in)
Caliper piston O.D.	30.148-30.149 mm (1.1869-1.1889 in)	30.140 mm (1.1866 in)
Caliper cylinder I.D.	30.230-30.280 mm (1.190-1.1921 in)	30.290 mm (1.1925 in)

### BRAKE PAD REPLACEMENT

Remove the lock bolt and the pin retainer.

Slowly press the caliper against the disc to push the pistons back into their cylinders. This is necessary to make room for the increased thickness of the new pads.

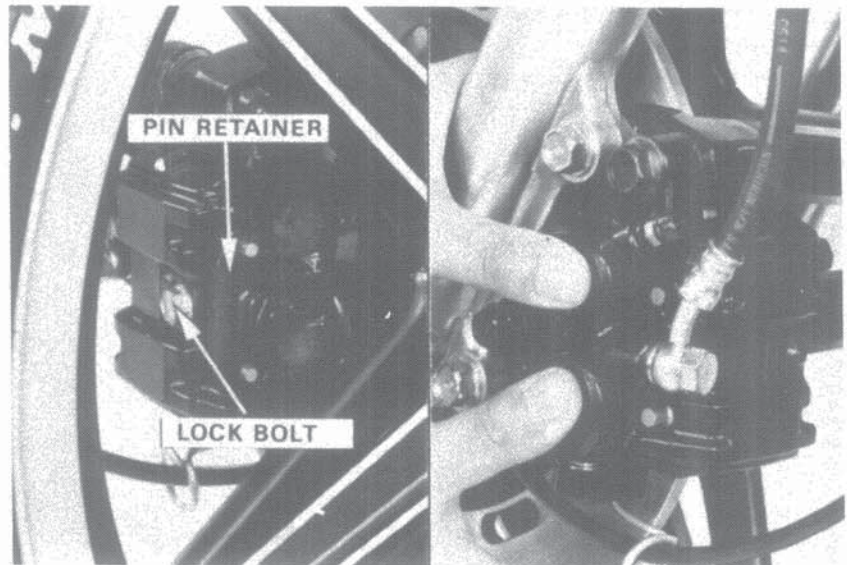

Remove the caliper mounting bolt.

Remove the caliper shaft and brake caliper.

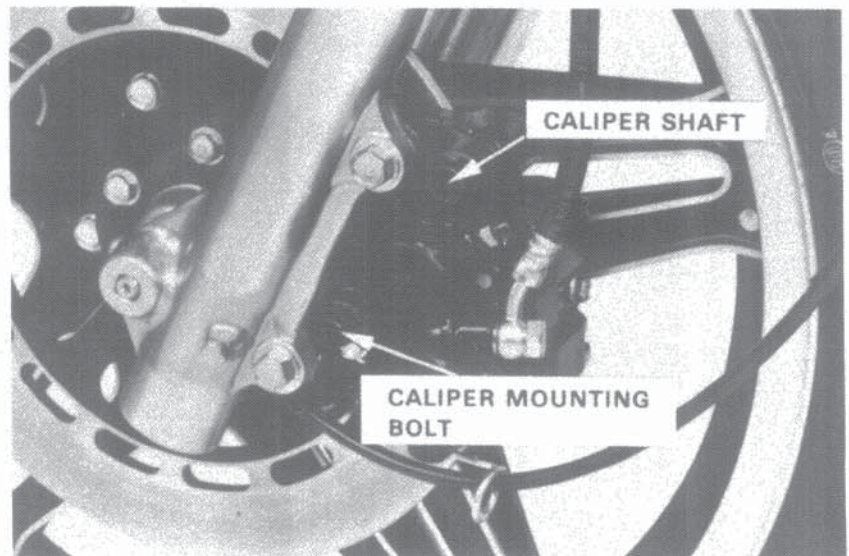





## '82 ADDENDUM

Pull out the brake pad pins and remove the brake pads.

Install new brake pads and insert the brake pad pins.

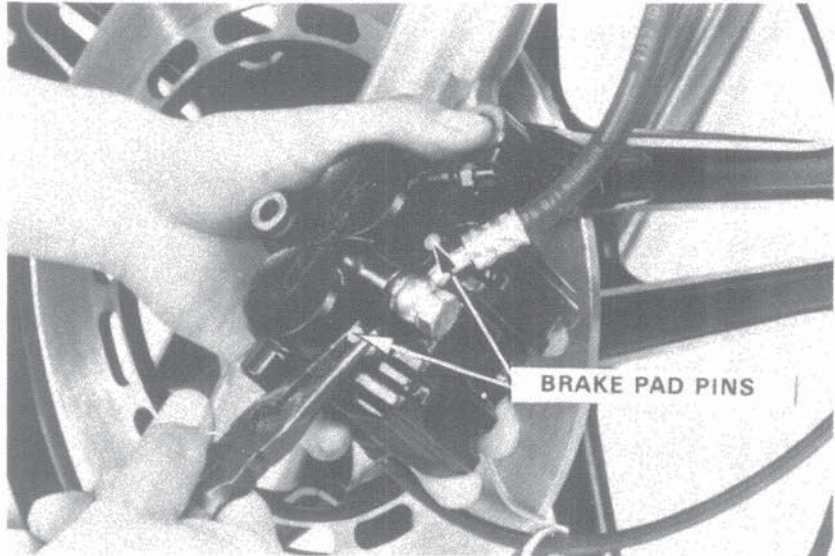

Install the caliper shaft into the caliper.

Install the caliper.

Tighten the caliper mounting bolt and the caliper shaft to specified torque.

### TORQUE:

**CALIPER MOUNTING BOLT: 2.0-2.5 kg-m**  
(14-18 ft-lb)

**CALIPER SHAFT: 2.5-3.0 kg-m**  
(18-22 ft-lb)

Install the brake pad pin retainer.

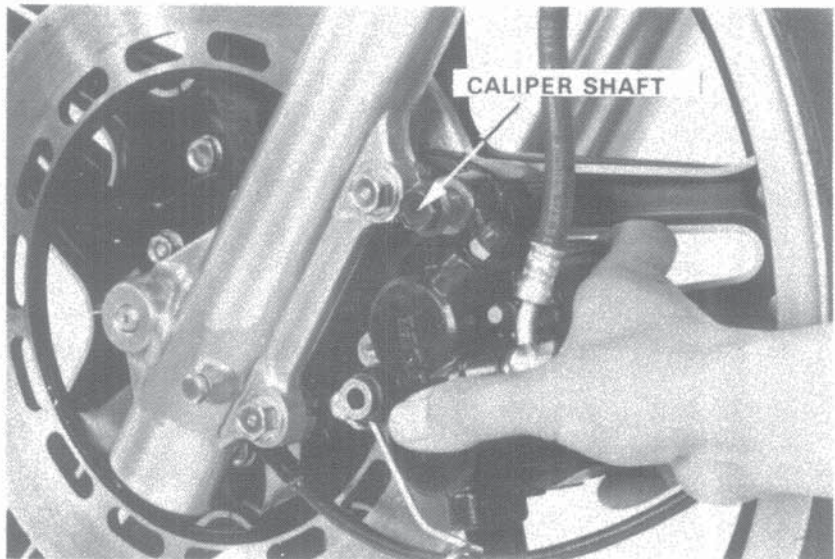

## BRAKE CALIPER DISASSEMBLY

Place a container under the caliper and disconnect the brake hose bolt.

### NOTE

Avoid spilling brake fluid on painted surfaces.

Remove the brake pads.

Remove the caliper shaft and caliper mounting bolt.

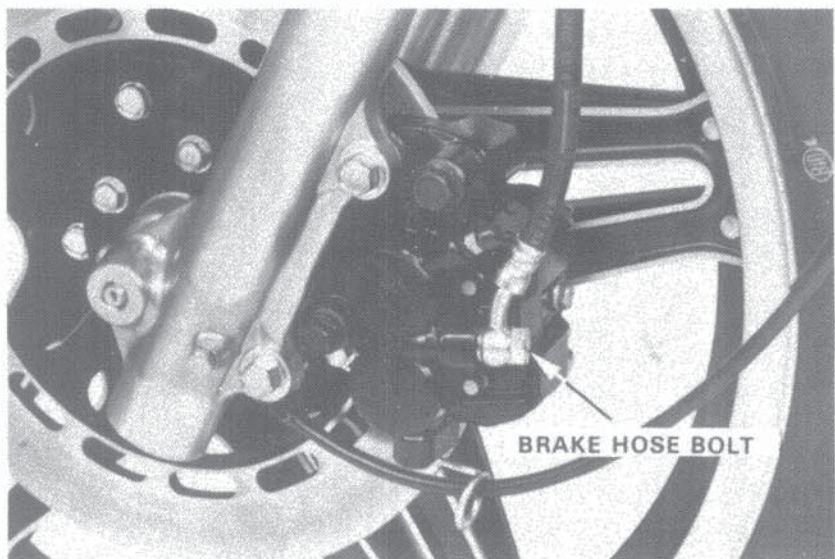





Remove the collar and boot.  
Remove the pad spring.

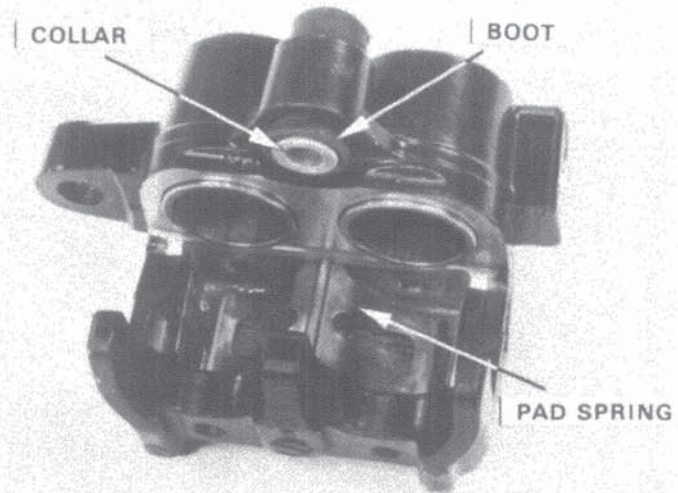

Place a shop towel over the pistons and position the caliper with the pistons down.  
Remove the pistons by applying a small amount of air pressure to the fluid inlet.

**WARNING**

*Do not use high pressure air or bring the nozzle too close to the inlet.*

Examine the pistons and cylinders for scoring or scratches and replace if necessary.

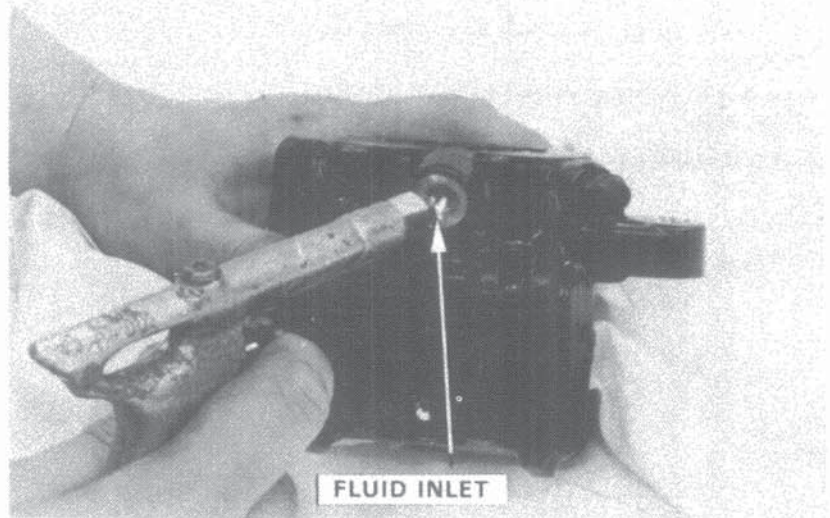

Remove the oil seals from the cylinders as shown.

Clean the caliper grooves with brake fluid.

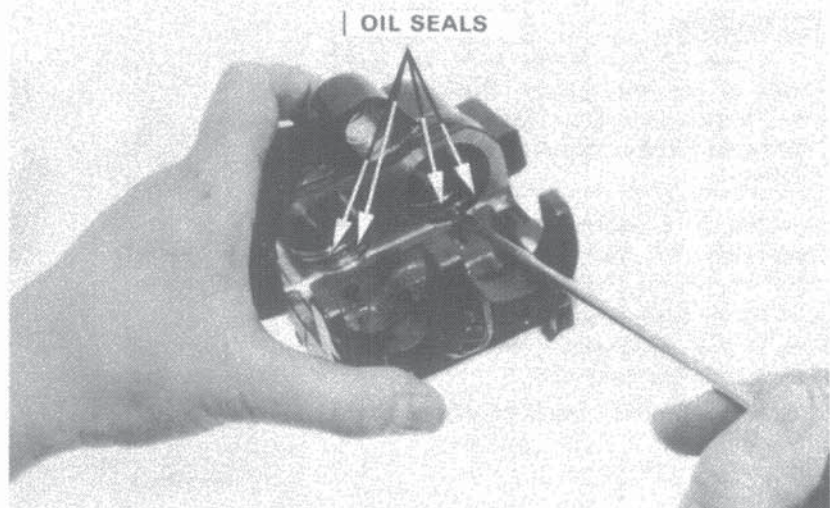





**'82 ADDENDUM**

**INSPECTION**

**CALIPER PISTON O.D.**

Check each piston for scoring or scratches.  
Measure the outside diameter of each piston with a micrometer.

**SERVICE LIMIT: 30.140 mm (1.1866 in)**

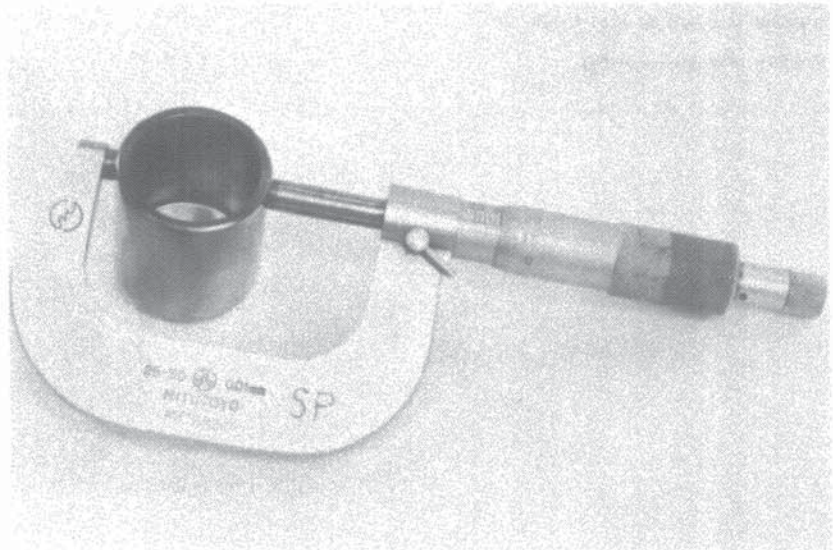

**CALIPER CYLINDER I.D.**

Check each caliper cylinder for scoring or scratches.  
Measure the inside diameter of each caliper cylinder bore.

**SERVICE LIMIT: 30.290 mm (1.1925 in)**

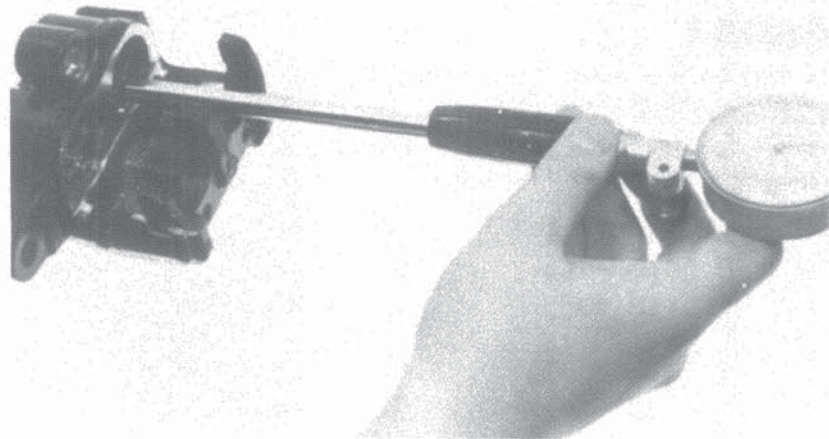

**ASSEMBLY**

**WARNING**

*A contaminated brake disc or pad reduces stopping power. Replace contaminated pads, and clean a contaminated disc with a good quality degreasing agent.*

Assemble the caliper in the reverse order of disassembly. The oil seals must be replaced whenever they are removed.

Lubricate the pistons and seals with a medium grade of high temperature silicon grease or brake fluid before assembly.

Make sure the piston seals are seated in the caliper grooves.

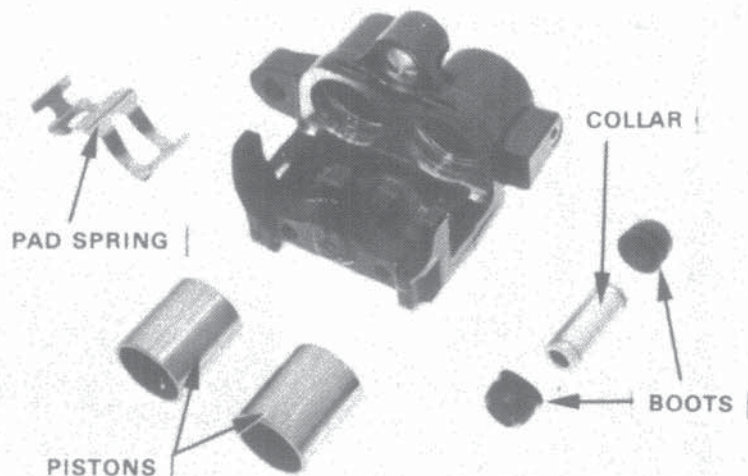



### CALIPER BRACKET INSPECTION

Remove the dust cover from the caliper bracket and check it for damage.

Check that the caliper bracket plate is correctly seated on the bracket.

If necessary, cement the plate to the bracket with Loctite 601 or an equivalent cement.

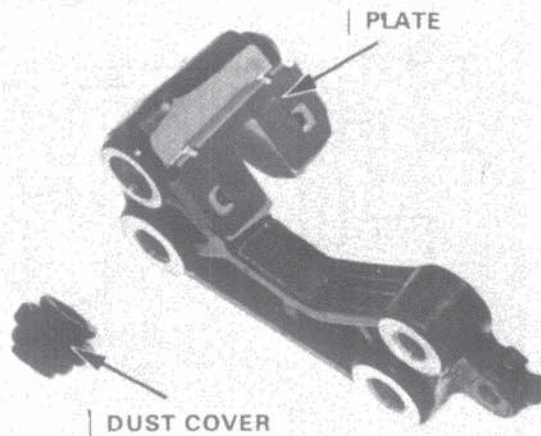

### CALIPER INSTALLATION

Install the brake pads and the caliper.

Tighten the caliper mount bolt and caliper shaft to the specified torque.

**TORQUE:**

**CALIPER MOUNT BOLT: 2.0-2.5 kg-m**  
**(14-18 ft-lb)**

**CALIPER SHAFT: 2.5-3.0 kg-m**  
**(18-22 ft-lb)**

Connect the brake hose.

Fill the brake fluid reservoir and bleed the front brake system (see page 3-10).

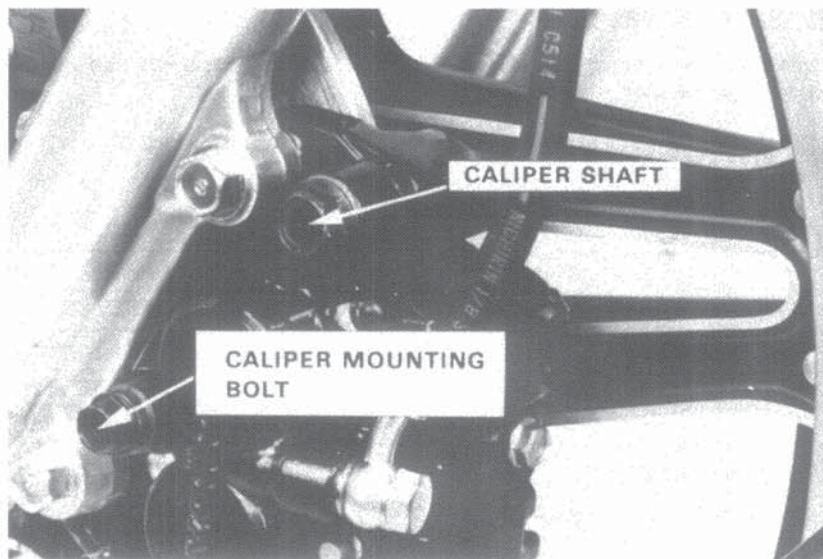





## 6. IGNITION SYSTEM

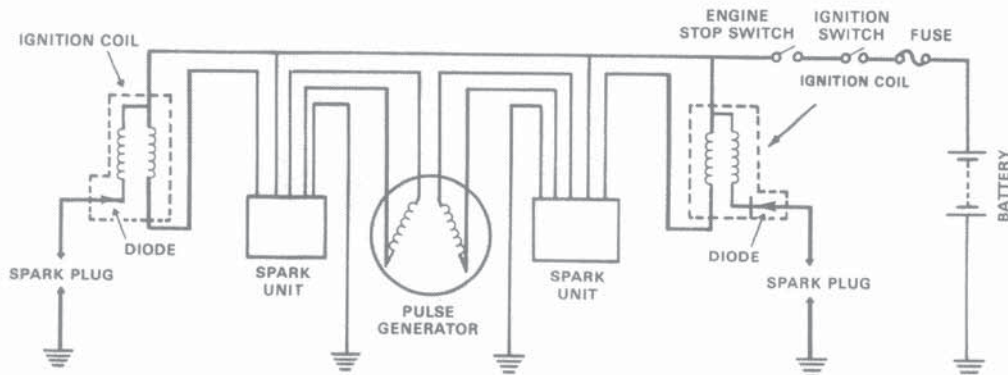

## SERVICE INFORMATION

### GENERAL INSTRUCTION

A transistorized ignition system is used and no adjustments are to be made unless the pulse generator screws are loosened or the pulse generator is removed.

### SPECIFICATIONS

ITEM		SPECIFICATION
Spark plug	Standard	DR8ES-L (NGK) or X24ESR-U (ND)
	For extended high-speed riding	DR8ES (NGK) or X27ESR-U (ND)
Spark plug gap		0.6-0.7 mm (0.024-0.028 in)
Ignition timing	"F" mark	15° BTDC/1,100 ± 100 rpm
	Full advance	40° ± 1.5° BTDC/2,780 rpm
Pulse generator air gap		0.40-0.70 mm (0.016-0.028 in)
Ignition coil 3-point spark test		6 mm (1/4 in) minimum

## TROUBLESHOOTING

Engine cranks but will not start

- Engine stop switch OFF.
- No spark at plugs
- Faulty transistorized spark unit
- Faulty pulse generator

No spark at plug

- Engine stop switch OFF
- Poorly connected, broken or shorted wires
  - Between ignition switch and engine stop switch
  - Between spark unit and engine stop switch
  - Between spark unit and ignition coil
  - Between ignition coil and plug
  - Between spark unit and pulse generator

- Faulty ignition coil
- Faulty ignition switch
- Faulty spark unit
- Faulty pulse generator

Engine starts but runs poorly

- Ignition primary circuit
  - Faulty ignition coil
  - Loose or bare wire
  - Intermittent short circuit
- Secondary circuit
  - Faulty plug
  - Faulty high tension cord
- Timing advance incorrect
  - Centrifugal advancer faulty



### IGNITION COIL REMOVAL

Remove the seat and fuel tank.  
Disconnect the ignition switch couplers.  
Remove the ignition coils attaching bolts and  
remove the coils.

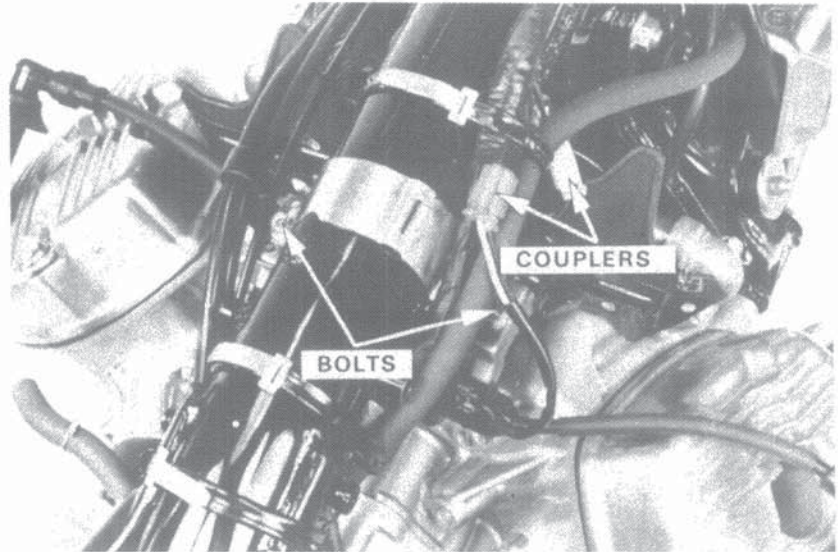

### PERFORMANCE TEST

Perform a 3-point spark test with a coil tester.

**SERVICE LIMIT: 6 mm (1/4 in) min**

#### NOTE

Follow the coil tester manufacturer's  
instructions.

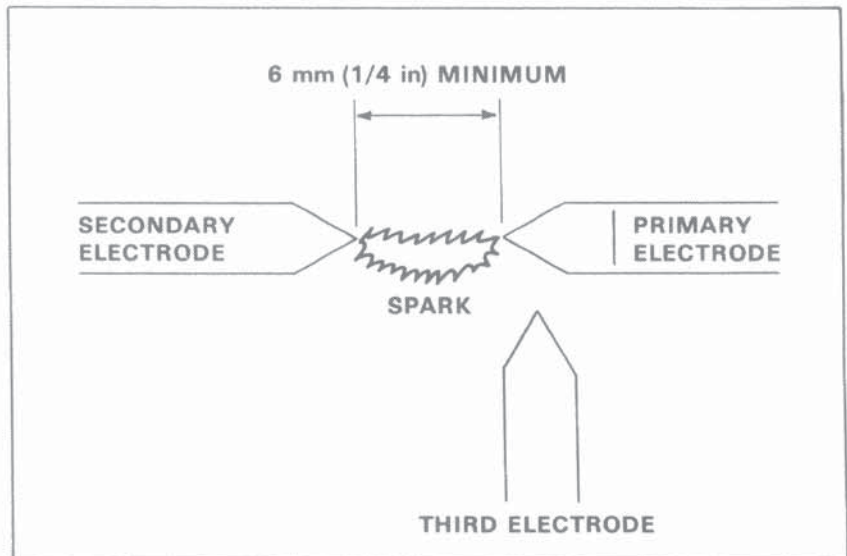

### PRIMARY COIL INSPECTION

Check the resistance of each ignition coil  
between the leads with an ohmmeter as shown.

**RESISTANCE: 2-3  $\Omega$**

Replace the coil if the resistance exceeds the  
specified range.

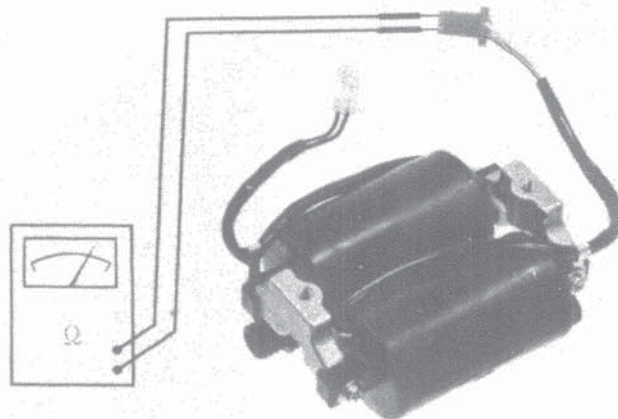





**'82 ADDENDUM**

**SECONDARY COIL INSPECTION**

Measure the resistance between the black/white terminal of the coupler and the high-tension terminal.

**NOTE**

- Use SANWA tester (07308-0020000) or KOWA tester (TH-5H-1)
- Use serviceable batteries for this test.

Test 1. Connect the negative probe of the tester to the coupler terminal and the positive probe to the high-tension terminal and measure the resistance.

**RESISTANCE: SANWA TESTER:**  
200-350 k $\Omega$   
**KOWA TESTER: 50-200 k $\Omega$**

Test 2. Reverse the tester polarities and measure the resistance.

**RESISTANCE:  $\infty$**

Replace the ignition coil if the resistances of tests 1 and 2 exceed the limits.

**TRANSISTORIZED IGNITION SYSTEM INSPECTION**

Disconnect the spark plugs.

Hold each plug against any convenient engine ground.

Turn the ignition switch ON and run the engine with the starter motor.

A good spark to the plug means that the ignition system is in good condition.

If it is not, inspect the pulse generator, spark unit and spark advancer.

**PULSE GENERATOR**

Measure the pulse coil resistance between the yellow leads (right cylinder), and between the blue leads (left cylinder) in the coupler.

**COIL RESISTANCE: 530  $\pm$  50 at 20°C (68°F)**

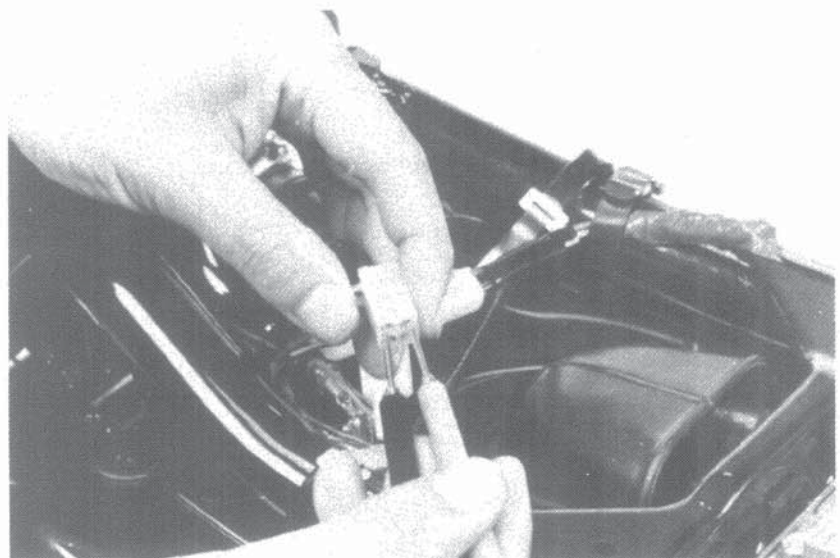
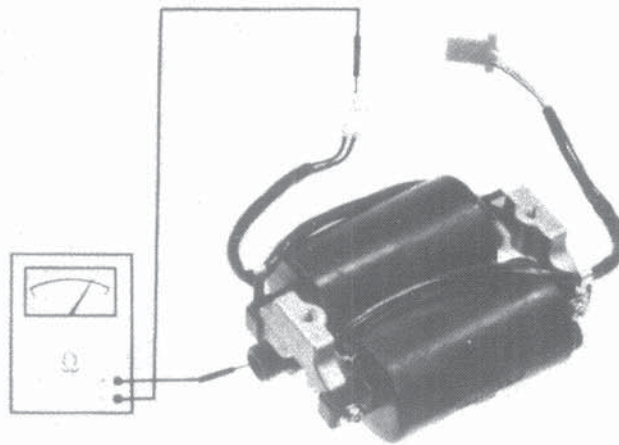



### SPARK UNIT

Disconnect the wire at the pulse generator coupler.

Attach the positive lead of a voltmeter to the blue with yellow tube wire terminal (left) or yellow with white tube wire terminal (right) of the 6-pole coupler. Attach the negative lead to any convenient ground. Turn the ignition switch on.

Ground each corresponding terminal, blue with white tube wire terminal (left), or yellow with white tube wire terminal (right) of the 4-pole coupler intermittently.

The transistor unit is normal if the voltage indicated by the voltmeter changes from 12V to 0V in each test.

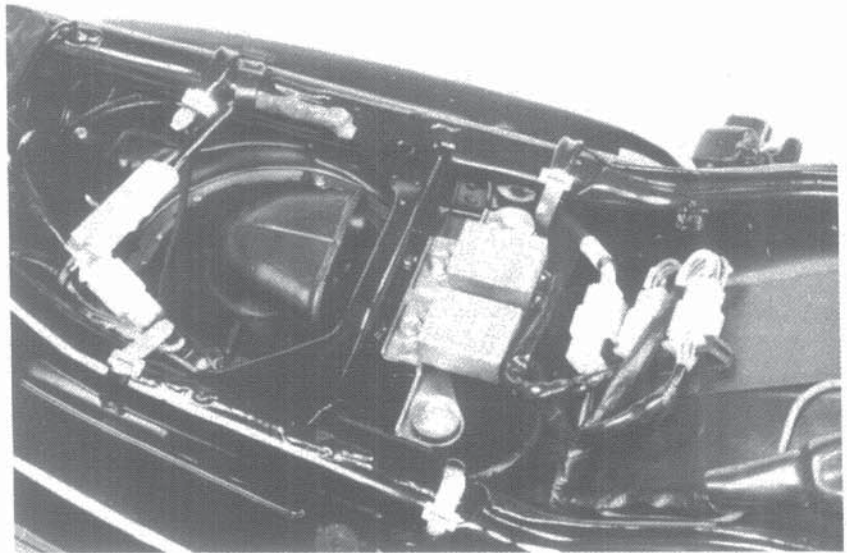

### SPARK ADVANCER

Remove the pulse generator (see page 25-9). Check the mechanical advancer cam for sticking.

Lubricate the sliding surfaces, and check the spring for loss of tension and the advancer pin for excessive wear.

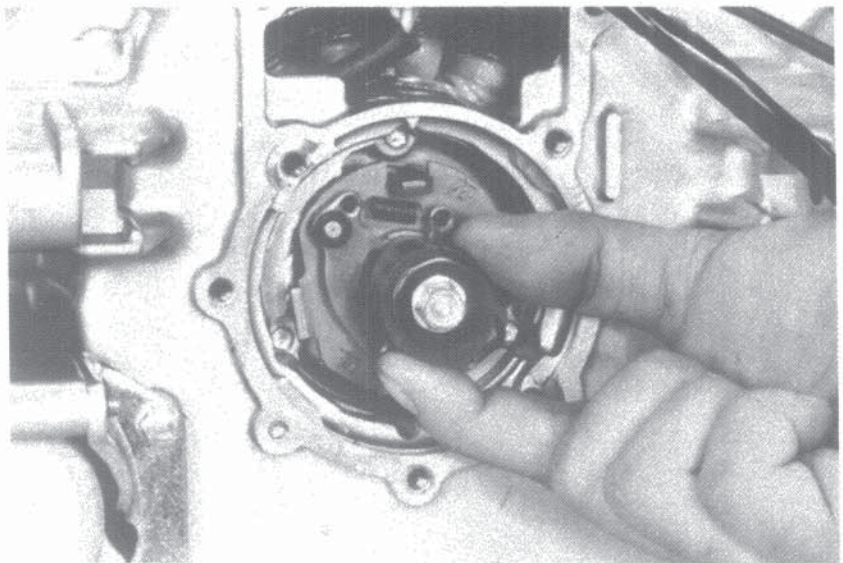

### SPARK ADVANCER ASSEMBLY

When assembling, align the rotor tooth with the cut-out in the advancer.

Install the spark advancer.

Install the pulse generator and adjust the ignition timing (see page 25-11).

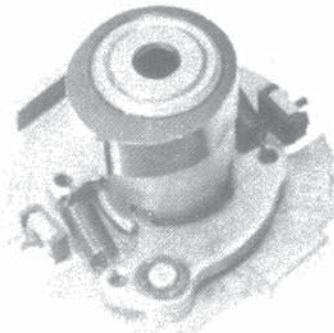





**'82 ADDENDUM**

**PULSE GENERATOR AIR GAP  
ADJUSTMENT**

Measure the air gaps between the rotor tooth and the pulse generator coils.

**AIR GAP: 0.40-0.70 mm (0.016-0.028 in)**

When adjustment is necessary, loosen the screws and move the coil to achieve the correct gap.

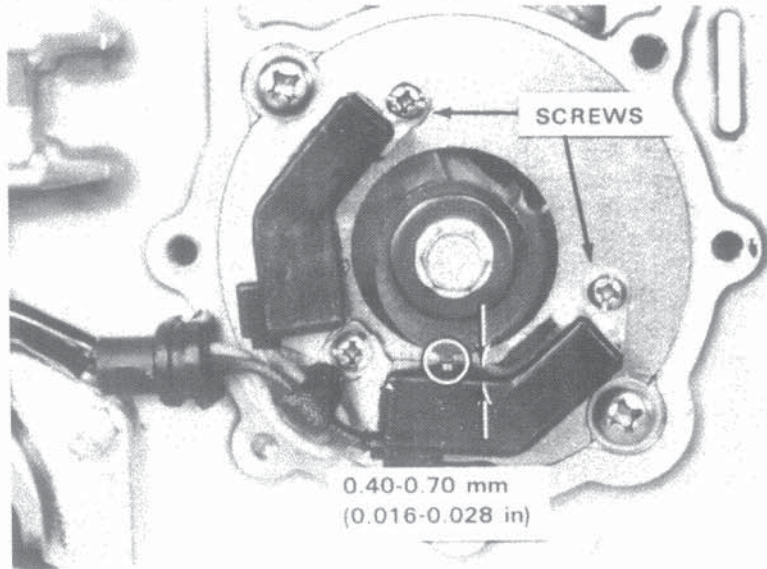

**IGNITION TIMING CHECK**

Remove the timing hole cap.

Connect a timing light to the right cylinder and connect a tachometer.

Start the engine and check the ignition timing.

The index mark should be aligned with the FI (for "idle") mark at  $1,100 \pm 100$  rpm.

Timing advance should start at  $1,500 \pm 100$  rpm.

The index mark should be between the full advance marks at 2,780 rpm.

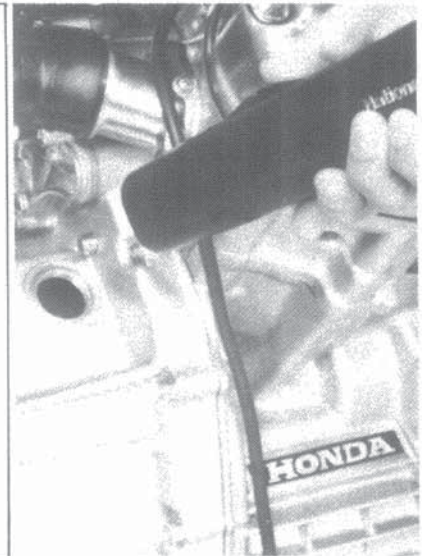
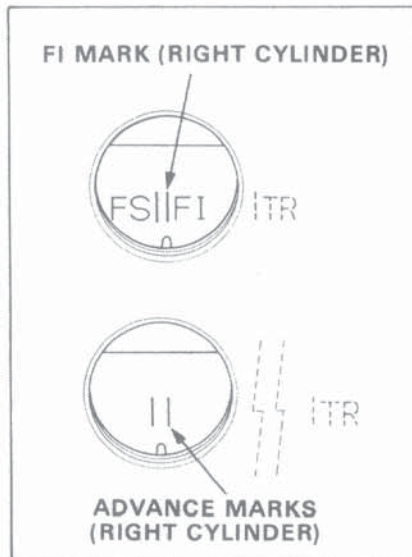

Repeat for the left cylinder, using the left cylinder timing marks.

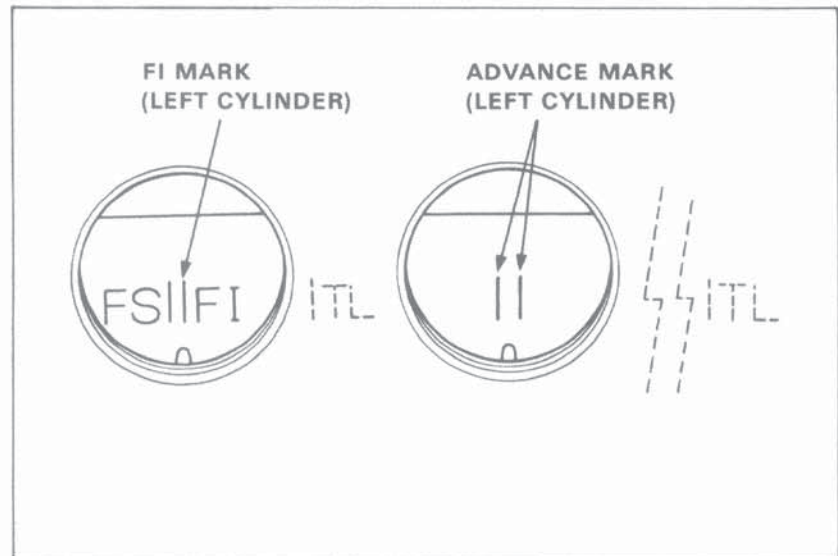



### 8. WIRING DIAGRAM

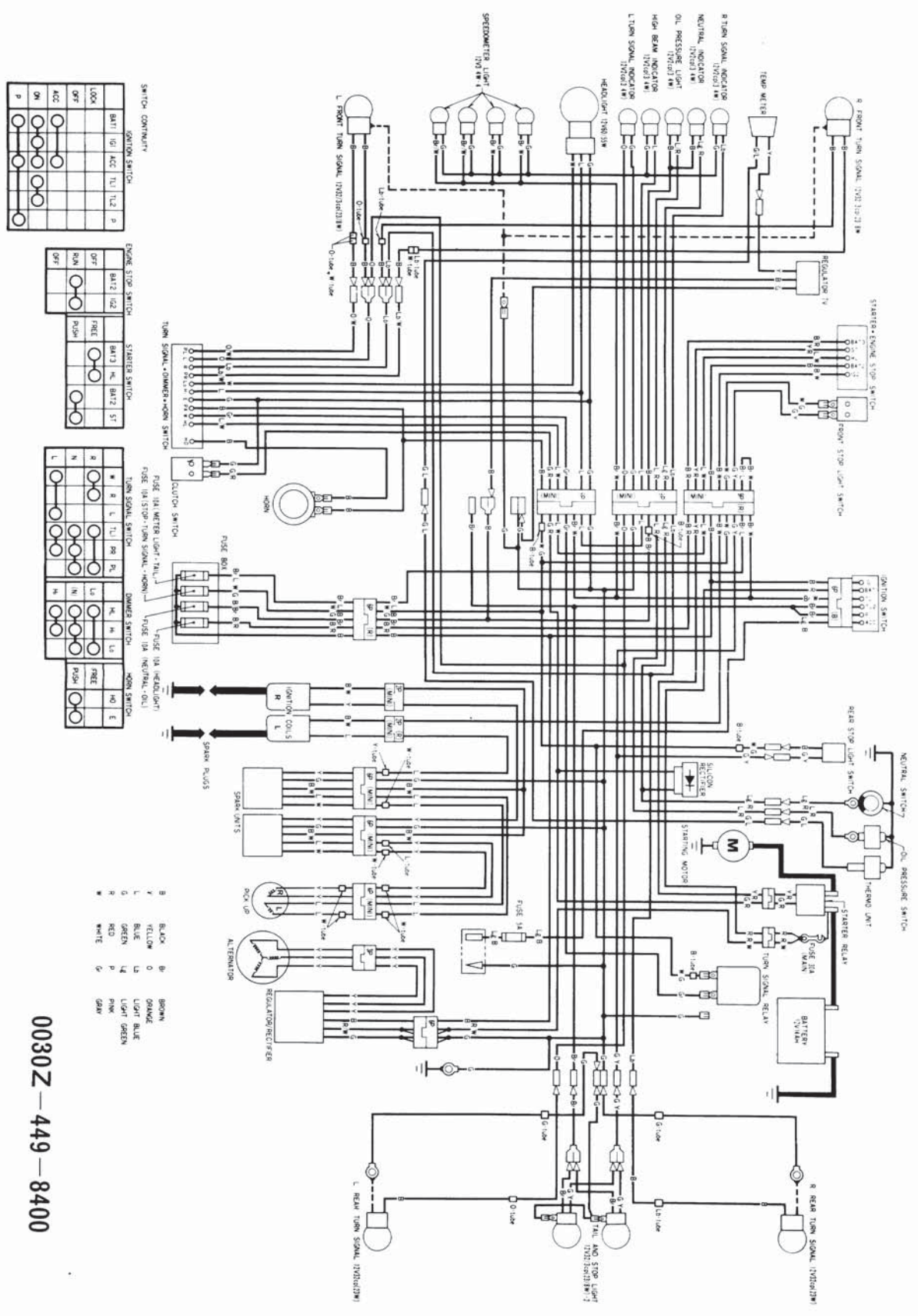

SWITCH CONTINUITY

IGNITION SWITCH		ENGINE STOP SWITCH		STARTER SWITCH	
BATT	IGN	ACC	TL	TL2	P

ENGINE STOP SWITCH		STARTER SWITCH	
BATT	IGN	BATT	ACC

TURN SIGNAL SWITCH		HORN SWITCH	
R	L	FRONT	REAR

TURN SIGNAL SWITCH		HORN SWITCH	
R	L	FRONT	REAR

B	BLACK	B	BROWN
Y	YELLOW	O	ORANGE
L	BLUE	LB	LIGHT BLUE
G	GREEN	LG	LIGHT GREEN
R	RED	P	PINK
W	WHITE	G	GRAY

0030Z-449-8400